



REPORT

Audit of H2 2020 Performance Reports

Iluka Resources Limited, Douglas Mine Pit 23 by-product disposal site

Submitted to:

Stuart Alexander

Iluka Resources Limited

Locked Bag 1001

Hamilton Vic 3000

Submitted by:

Golder Associates Pty Ltd

Building 7, Botanicca Corporate Park 570 – 588 Swan Street Richmond, Victoria 3121

Australia

+61 3 8862 3500

19121052-011-R-Rev0

September 2021

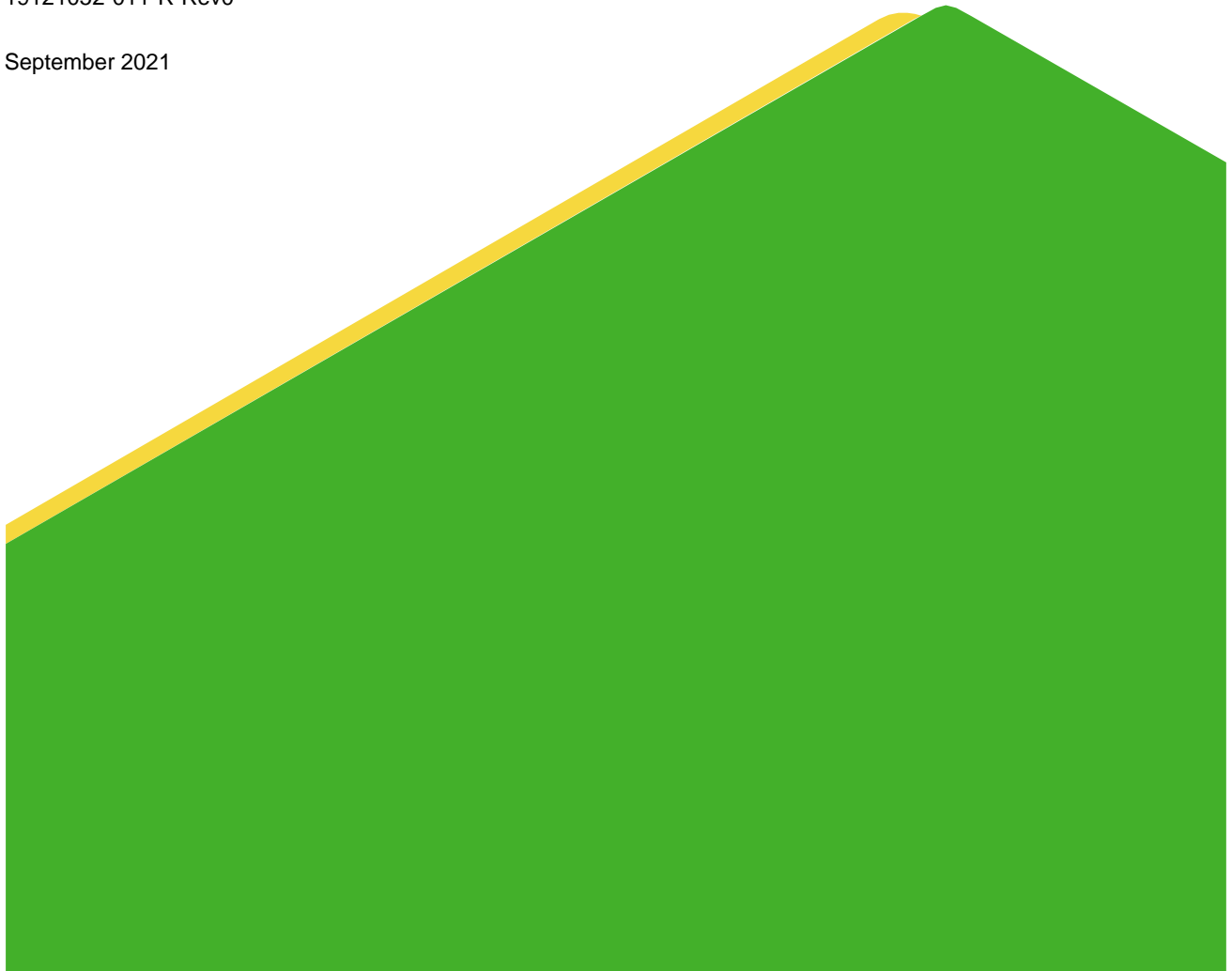

Distribution List

Electronic Copy:

1x Iluka resources

1x Golder Associates

Table of Contents

1.0 INTRODUCTION	1
2.0 PLANNING PERMIT REQUIREMENTS	1
2.1 Methodology.....	1
2.2 Incoming Waste Monitoring Plan	2
2.3 Environmental Management Plan.....	2
2.4 Rehabilitation and Vegetation Management Plan.....	3
3.0 ENVIRONMENTAL AUDITOR.....	3
4.0 SITE LOCATION	4
5.0 INCOMING WASTE MONITORING PLAN PERFORMANCE REPORT	5
6.0 ENVIRONMENTAL MANAGEMENT PLAN AND REHABILITATION PERFORMANCE REPORT	5
7.0 REHABILITATION AND VEGETATION MANAGEMENT PLAN.....	6
8.0 OTHER PREVIOUS AUDIT FINDINGS	6
9.0 REFERENCES	11
10.0 IMPORTANT INFORMATION.....	12
11.0 CLOSING	12

TABLES

Table 1: Response to previous audit recommendations	7
Table 2: IWMP Performance Report Audit	1
Table 3: EMP Performance Report Audit	1

TABLES (attached)

Table A: Duplicate and blank analytical results – November 2020

FIGURES

Figure 1: Site Location Plan.....	5
-----------------------------------	---

APPENDICES

APPENDIX A

IWMP Performance Report Audit

APPENDIX B

EMP & RVMP Performance Report Audit

APPENDIX C

Iluka IWMP Performance Report H2 2020

APPENDIX D

Iluka EMP & IWMP Performance Report H2 2020

APPENDIX E

Important Information

1.0 INTRODUCTION

Golder Associates Pty Ltd (Golder) was engaged by Iluka Resources Limited (Iluka) to undertake an independent audit of the Performance Reports for the Pit 23 By-products Disposal Facility, located in the municipality of the Horsham Rural City in the Kanagulk area (the site). The independent audit (audit) is a requirement of Planning Permit 15-105 (the planning permit), issued by Horsham Rural City Council (Council). The Performance Reports, prepared by Iluka, provide a summary of the waste acceptance, monitoring and management undertaken at the site during the half year ended 31 December 2020. The two Performance Reports prepared by Iluka for H2 2020 are as follows:

- *Environmental Management Plan and Rehabilitation Performance Report* (EMP Performance Report) H2 2020; and,
- *Incoming Waste Monitoring Plan Performance Report* (IWMP Performance Report) H2 2020.

The EMP Performance Report is audited against the criteria listed in Section 12.2 and 13.2 of Iluka's *Pit 23 Environmental Management Plan Rev 4* (EMP). Similarly, the IWMP Performance Report is audited against the criteria listed in Section 6 of Iluka's *Pit 23 Incoming Waste Monitoring Plan Rev 4* (IWMP).

The H2 2020 Performance Reports are provided in APPENDIX C (IWMP) and APPENDIX D (EMP & RVMP).

The Performance Reports cover the period from 1 July 2020 to 31 December 2020.

2.0 PLANNING PERMIT REQUIREMENTS

Regarding the audit of the IWMP and EMP Performance Reports, the relevant conditions of the planning permit include:

14 (e): annual auditing of records to verify compliance with the requirements of the Incoming Waste Monitoring Plan (IWMP).

20: The annual performance report must be reviewed by an independent suitably qualified person with expertise in risk management plans in the context of mines and quarries, and is an environmental auditor appointed under the EP Act 1970.

31: The permit holder must submit an annual performance statement (within the wider EMP Annual Report).

42: The permit holder must prepare an EMP and Rehabilitation performance review report covering its compliance requirements under the various sub-components of the EMP and R&VMP [Rehabilitation and Vegetation Management Plan] for provision to a suitably qualified environmental auditor as agreed by the Responsible Authority annually or less frequently as agreed to in writing, by the Responsible Authority.

43: The environmental auditor must review the EMP and Rehabilitation performance review report and provide conclusions on the report's content against its key sub-components, and recommendations for any required amendments to the plans ('auditor's review').

2.1 Methodology

The Performance Reports were audited against the relevant requirements of Section 6 of the IWMP and Section 12.2 and 13.2 of the EMP. Additional documentation was sought from Iluka as needed to provide evidence of compliance with relevant sections of the IWMP and EMP.

Due to the limited activities occurring at the site, a site inspection was not conducted as part of the audit. Assessment was therefore limited to desktop review of the Performance Reports and supporting documentation.

The recommendations of the previous Performance Reports (AECOM, 2017; Golder, 2018; Golder, 2019; Golder, 2020) were also considered and a review of Iluka's response to these recommendations is provided in Section 8.0.

The audit of the IWMP Performance Report, EMP Performance Report and actions undertaken regarding previous audit report recommendations assessed compliance according to:

- 'Compliant'. The information indicated that the relevant requirement of the planning permit or plan had been met.
- 'Not Compliant'. The information indicated that the relevant requirement of the planning permit or plan had not been met.
- 'Not Applicable'. The relevant requirement was not applicable due to the operational status of the plant or the Auditor was unable to determine compliance due to the requirement being outside the scope of the audit.

2.2 Incoming Waste Monitoring Plan

The IWMP has been prepared to satisfy the requirements of Condition 14 of the Planning permit, namely:

14. Within 90 days of the commencement of this permit operating, an Incoming Waste Monitoring Plan (IWMP) must be submitted to the satisfaction of the responsible authority and the Department of Health and Human Services for approval by the responsible authority. Three copies of the IWMP must be submitted to the responsible authority. When approved by the responsible authority the IWMP will be endorsed and it will then form part of this permit. The IWMP must provide for:

- a. A monitoring and reporting system for ensuring that materials disposed of to Pit 23 are limited to those permitted under the conditions of this permit;*
- b. Recording of the origin, per load weight and radioactive properties of each incoming load;*
- c. Monitoring to ensure all vehicles transporting waste have fully secured and contained loads and that all waste loads have been transported in compliance with licensed requirements under the Radiation Act 2005;*
- d. Records of any transport incidents or spills and remedial actions taken in the event of such incidents; and*
- e. Annual auditing of records to verify compliance with the requirements of the IWMP.*

This audit has reviewed the IWMP Performance Report against relevant planning permit criteria, and Section 6 of the IWMP.

2.3 Environmental Management Plan

The EMP has been prepared by Iluka to provide a framework for the management and monitoring of disposal operations at Pit 23. The EMP outlines:

- The operational, environmental and legal context for the permitted development;
- The operational methods to be used;

- Environmental issues that could compromise environmental performance if not managed appropriately; and,
- The monitoring program to be used for assessing the environmental performance and impact of Pit 23.

This audit has reviewed the EMP Performance Report against relevant planning permit criteria, and Section 12.2 and 13.2 of the EMP.

Previous Auditor recommendations to review the EMP have been considered by development of a revised EMP (Revision 5.1). The Auditor's review of the EMP Revision 5.1 has been provided separately (Golder, 2020c). We understand that EMP Revision 5.1 will be applied for monitoring and assessment from 2021 onwards. The H2 2020 monitoring and assessment of results were conducted under the Revision 4 EMP (Iluka, 2017) and this Audit compares the performance reports to the requirements of the Revision 4 EMP.

2.4 Rehabilitation and Vegetation Management Plan

The *Rehabilitation and Vegetation Management Plan 2017* (RVMP) has been prepared by Iluka to provide a detailed management framework for rehabilitation of Pit 23. The RVMP outlines:

- The end use and rehabilitation objectives for the subject land;
- The methods to be used for rehabilitation and revegetation;
- Key issues that may compromise rehabilitation outcomes; and,
- Completion criteria and further monitoring post completion.

In relation to the audit of the *Rehabilitation and Vegetation Management Plan 2017*, the relevant planning permit requirements are:

42: The permit holder must prepare an EMP and Rehabilitation performance review report covering its compliance requirements under the various sub-components of the EMP and RVMP for provision to a suitably qualified environmental auditor as agreed by the Responsible Authority annually or less frequently as agreed to in writing, by the Responsible Authority.

43: The environmental auditor must review the EMP and Rehabilitation performance review report and provide conclusions on the report's content against its key sub-components, and recommendations for any required amendments to the plans ('auditor's review').

As of the writing of this audit, Pit 23 was still accepting material and as such, rehabilitation or revegetation has not yet been undertaken by Iluka. There are therefore no findings regarding the RVMP.

3.0 ENVIRONMENTAL AUDITOR

This audit review was undertaken by Bruce Dawson who is appointed as an Environmental Auditor (Industrial Facilities) under the *Environment Protection Act 1970*.

Bruce has over 30 years' experience in environmental management issues, encompassing industrial planning and assessment, auditing and policy development. Bruce joined Golder in 2010 as a Principal Environmental Consultant leading the development of performance assurance and industry sustainability services in the Melbourne office.

Bruce has extensive experience in assessing environmental performance and impact and associated strategies for effective management of statutory obligations in waste management, industrial operations, land development and infrastructure development.

Bruce was previously employed with the Environment Protection Authority Victoria for 24 years. He was part of EPA's executive leadership team for 8 years, providing a key role in leading operational and policy program areas and lead implementation of EPA's environmental audit program.

Bruce undertakes auditing and assessment of landfill design and construction and risks associated with landfill gas migration. Bruce has extensive experience in development of environmental management plans and environmental policy to reduce environmental impact and compliance risks.

Bruce was supported by the following Golder personnel:

- Stephen Makin, Senior Hydrogeologist,
- Coen Romalis, Environmental Scientist.

4.0 SITE LOCATION

The Douglas Mineral Sands Mine (shown in Figure 1) is located in the municipality of the Horsham Rural City in the Kanagulk area. Iluka produces a number of by-products from its heavy mineral processing operation at its mineral separation plant (MSP) in Hamilton. The by-products produced from this processing are transported by truck from the Hamilton site to the Douglas Mine Site, where it is then disposed of in a mining void known as Pit 23. Pit 23 is shown in Figure 1. The IWMP and EMP apply management controls specifically to Pit 23 and its associated operations.

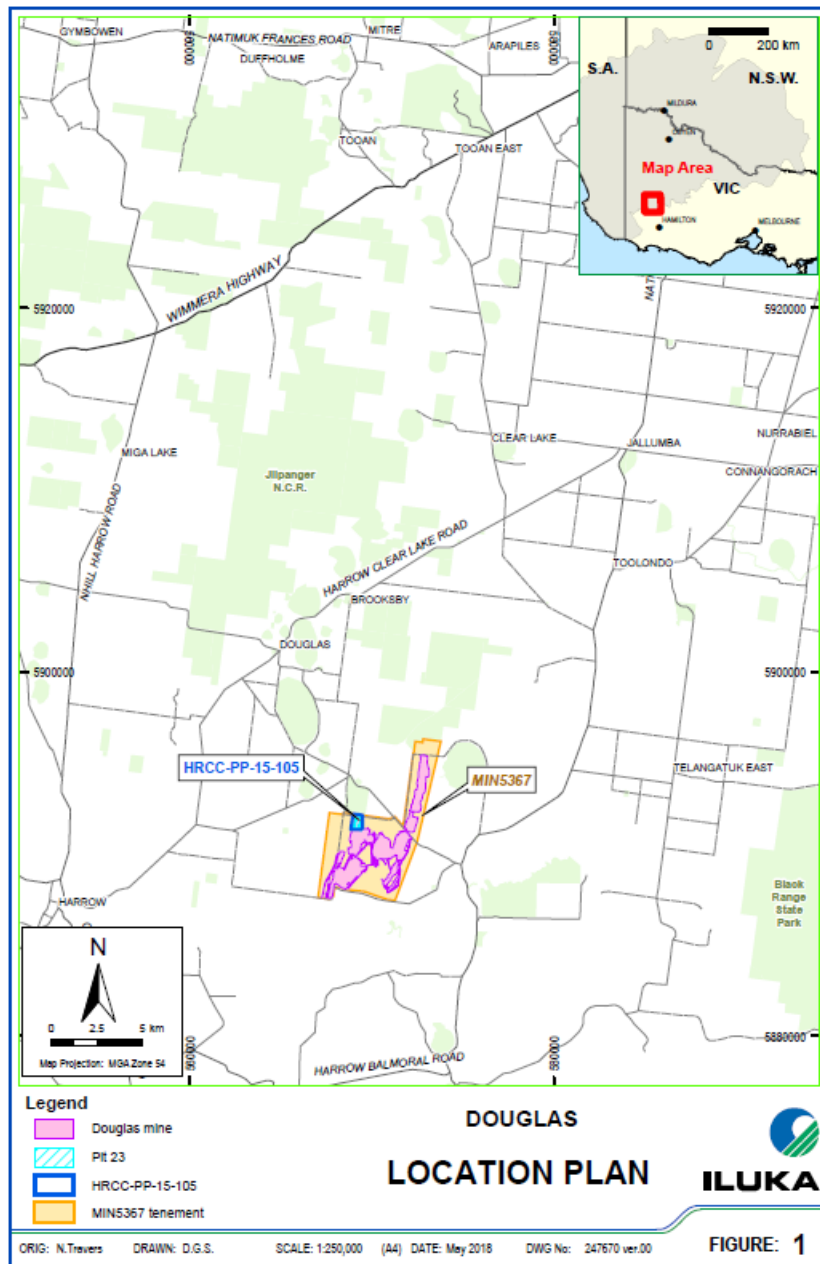

Figure 1: Site Location Plan

5.0 INCOMING WASTE MONITORING PLAN PERFORMANCE REPORT

The Auditor’s review of the IWMP Performance Report is attached as APPENDIX C. The review found that the Performance Report is in accordance with Section 6 of the IWMP.

6.0 ENVIRONMENTAL MANAGEMENT PLAN AND REHABILITATION PERFORMANCE REPORT

The Auditor’s review of the EMP Performance Report is attached as APPENDIX D. The review found that the Performance Report is generally in accordance with Section 12.2 and 13.2 of the EMP. The Auditor makes the following recommendations:

- Analysis results for one duplicate groundwater sample and one field blank sample were supplied (from November 2020), along with laboratory reports for routine sampling. QAQC data quality validation should be included in the annual performance report.
- The EMP requires Iluka to construct groundwater elevation contours for each monthly groundwater gauging round. Although groundwater hydrographs were reported for the monitoring period, which indicate generally consistent water levels, only contours from the previous reporting period were presented (June 2020). At least one interpretation from the reporting period should be supplied as part of the Performance Report.

7.0 REHABILITATION AND VEGETATION MANAGEMENT PLAN

The RVMP reporting requirements are listed in Section 2.4 of this report. Iluka's Performance Report for the RVMP was included in the EMP Performance Report.

Due to the current and continued operation of Pit 23, no actions required by the RVMP were undertaken during the H2 2020 reporting period.

8.0 OTHER PREVIOUS AUDIT FINDINGS

The audit of 2017 Mineral Sands By-product disposal reports (AECOM, 2017) was the first audit of the IWMP and EMP undertaken. Iluka has responded to a number of these recommendations in the 2018 and 2019 reporting periods. Outstanding recommendations from these reports are provided below.

Additionally, the recommendations from the audit of the 2018, H1 2019, H2 2019 and H1 2020 reporting periods by Golder (19121052-001-R, Golder, 2018; 19121052-003-R, Golder, 2019; 19121052-006-R, Golder, 2020a, 19121052-009-R, Golder, 2020b), are presented with Iluka's response below.

Table 1: Response to previous audit recommendations

Previous Audit Recommendation	Observation	Action Completed in H2 2020?	Recommendations
IWMP Performance Report			
Golder, 2018: Due to the infrequent disposal of material Iluka should consider revising the IWMP if it continues to be impracticable to calculate a weekly average for radionuclide properties.	The IWMP has been revised, with Revision 5 dated 29 October 2019. This was reviewed by the Auditor (Golder, 2020c) and was considered to satisfy this recommendation.	Completed	-
Golder 2018: As the IWMP will have been in operation for two years as at 17 July 2019, a review should be undertaken during the next reporting period. Iluka has confirmed that a review has commenced.	The IWMP has been revised, with Revision 5 dated 29 October 2019. This was reviewed by the Auditor (Golder, 2020c) and was considered to satisfy this recommendation.	Completed	The IWMP now requires review after a minimum of 3 years, so the next review would be due by the end of 2023, considering Revision 5 came into effect at the end of 2020.
EMP and RVMP Performance Report:			
Golder 2018: Future interpretations of results from GW04 should consider whether this well is located down-hydraulic gradient from Pit 23 (i.e. is it on the predicted flow path?).	Groundwater flow contours and numerical model flow paths presented in H1 2019 report indicate that GW04 is not directly down-gradient from Pit 23.	Completed	Iluka report installation of an additional bore between GW04 and BW36A in October 2020. This bore has been named GW04A and is indicated to lie within the modelled groundwater flow paths from Pit 23. GW04A was included in the revised EMP (Revision 5.1) as a down-

Previous Audit Recommendation	Observation	Action Completed in H2 2020?	Recommendations
			gradient bore, with GW04 retained as a cross-gradient bore.
<p>Golder 2018:</p> <p>An additional well between BW36 and GW04 is recommended to be installed, considering that GW04 may not be located down-hydraulic gradient from Pit 23.</p>	<p>BW36 (blocked) was decommissioned and replaced with a new well BW36A in a similar location. The spacing between BW36A and GW04 of approximately 600 m is not considered to meet the intent of the monitoring network specified by the EMP.</p>	Completed	<p>Installation of an additional bore GW04A has reduced the spacing to approximately 350 m between GW04A and BW36A and approximately 250 m between GW04 and GW04A.</p>
<p>Golder, 2019; Golder, 2020a; Golder, 2020b:</p> <p>The EMP listed trigger levels for ion ratios should be reconsidered to identify consistent declining trends in concentration outside a range of natural fluctuation. Resampling for confirmation of exceedances should be conducted within the specified timeframe.</p>	<p>EMP has been revised (Version 5.1) for application to future monitoring. Auditor comment provided separately (Golder, 2020c).</p>	Completed in EMP Rev 5.1.	-
<p>Golder 2018:</p> <p>The EMP should be amended to refer to SEPP (Waters) and description of associated beneficial uses and environmental quality objectives</p>	<p>EMP has been revised (Version 5.1) for application to future monitoring. This was reviewed by the Auditor (Golder, 2020c) and was considered to satisfy this recommendation.</p>	Completed in EMP Rev 5.1.	-

Previous Audit Recommendation	Observation	Action Completed in H2 2020?	Recommendations
updated as required. Iluka should review TDS groundwater monitoring data to ensure the appropriate groundwater segment as described in SEPP (Waters) is identified.			
General Recommendations			
<p>Golder 2018</p> <p>The EMP contains a significant amount of background information on the environmental conditions relevant to Pit 23. This information provides useful context on the local conditions and aids in interpretation of monitoring results, however, to assist in the implementation of the EMP, it is recommended that this information be simplified or removed from the EMP (but available to the Auditor undertaking the review).</p>	<p>EMP has been revised (Version 5.1) for application to future monitoring. This was reviewed by the Auditor (Golder, 2020c) and was considered to satisfy this recommendation.</p>	<p>Completed in EMP Rev 5.1.</p>	<p>-</p>
<p>Golder 2018</p> <p>The management actions and monitoring requirements in the EMP should be clarified and consolidated to make it easier for Iluka personnel to clearly identify requirements and</p>	<p>EMP has been revised (Version 5.1) for application to future monitoring. This was reviewed by the Auditor (Golder, 2020c) and was considered to satisfy this recommendation.</p>	<p>Completed in EMP Rev 5.1.</p>	<p>-</p>

Previous Audit Recommendation	Observation	Action Completed in H2 2020?	Recommendations
associated procedures and to ensure the contents of the Performance Report align with the requirements of the EMP.			
<p>Golder 2018</p> <p>The reporting requirements currently in Section 12.2 of the EMP should be reviewed to ensure they are consistent with all of the relevant monitoring requirements contained in Sections 7, 8 and 9 of the EMP</p>	<p>EMP has been revised (Version 5.1) for application to future monitoring. This was reviewed by the Auditor (Golder, 2020c) and was considered to satisfy this recommendation.</p>	<p>Completed in EMP Rev 5.1.</p>	<p>-</p>

9.0 REFERENCES

AECOM Audit of 2017 Mineral Sands By-product Disposal Annual Reports.

Golder Associates, 2018. Audit of 2018 Mineral Sands By-product Disposal EMP and IWMP Annual Reports (19121052-001-Rev0).

Golder Associates, 2019. Audit of H1 2019 Mineral Sands By-product Disposal EMP and IWMP Annual Reports (19121052-003-Rev1).

Golder Associates, 2020a. Audit of H2 2019 EMP and IWMP Performance Reports, Douglas Mine Pit 23 by-product disposal site (19121052-006-Rev1).

Golder Associates, 2020b. Audit of H1 2020 EMP and IWMP Performance Reports, Douglas Mine Pit 23 by-product disposal site (19121052-009-Rev0).

Golder Associates, 2020c. Review of Updated EMP and IWMP (19121052-004-L-Rev0).

Iluka Resources Ltd, 2016. Radiation Management Plan- Murray Basin Operations (Rev2) August 2016.

Iluka Resources Ltd, 2017. Incoming Waste Monitoring Plan (Rev 4) 5 April 2017.

Iluka Resources Ltd, 2017. Environment Management Plan (Rev 4) 6 July 2017.

Iluka Resources Ltd, 2017. Rehabilitation and Vegetation Management Plan (Rev3) 12 April 2017.

Iluka Resources Ltd, 2021. Planning Permit 15-105, EMP & Rehabilitation Performance Report – H2 2020. (UDOCs 0058-1414587248-1098, FINAL_Rev0).

Iluka Resources Ltd, 2021. Planning Permit 15-105, Incoming Waste Monitoring Plan Report H2 – 2020 (UDOCs 0090-426461582-2341, Final Rev0).

Iluka Analytic Sampling Procedures

Analytical - Analysis using XRF 11/6/15.

Analytical - Moisture Determination 10/9/15.

Analytical - Sample Preparation - Fusion of Heavy Mineral 4/12/08.

Analytical - Sample Preparation - Pulverising Grinding Samples 18/10/14.

Analytical - Sample Preparation - Riffle Splitting 23/10/14.

Analytical - XRF QA 23/7/18.

High Volume Air Sampler, Sampling Procedure 26/7/17.

Trucking Procedures

Work Instruction for Loading of Monazite & Ilmenite CL product at Iluka MSP V8 Kalari P/L 28/09/2015.

Emergency Response Procedure for Non Conductor Magnetics V2 Kalari P/L 8/02/2011.

Work Instruction for unloading MSP rejects at Pit 23 V2 Kalari P/L 13/08/2015.

10.0 IMPORTANT INFORMATION

Your attention is drawn to the document titled - "Important Information Relating to this Report", which is included in APPENDIX E of this report. The statements presented in that document are intended to inform a reader of the report about its proper use. There are important limitations as to who can use the report and how it can be used. It is important that a reader of the report understands and has realistic expectations about those matters. The Important Information document does not alter the obligations Golder Associates has under the contract between it and its client.

11.0 CLOSING

If you have any queries about this report, please contact Bruce Dawson on 03 8862 3774 or at bdawson@golder.com.au.

Signature Page

Golder Associates Pty Ltd



Coen Romalis
Environmental Scientist



Bruce Dawson
Principal Environmental Consultant

CER/BED/cer

A.B.N. 64 006 107 857

Golder and the G logo are trademarks of Golder Associates Corporation

[https://golderassociates.sharepoint.com/sites/107372/project files/6 deliverables/19121052-011-r h2 2020 performance review/19121052-011-r-rev0.docx](https://golderassociates.sharepoint.com/sites/107372/project%20files/6%20deliverables/19121052-011-r%20h2%202020%20performance%20review/19121052-011-r-rev0.docx)

Tables

Table A - Duplicate and Blank Analytical Results - November 2020

Sample Description Sample Collection Method			GW_4A Received	Blind Received	RPD	Field Blank Received
Sample Taken Date/Time			30/11/2020 10:35am	30/11/2020 08:59am		30/11/2020 08:59am
Lab. Received Date/Time EML Lab. No.			02/12/2020 09:00am EML- 20599	02/12/2020 09:00am EML- 20600		02/12/2020 09:00am EML-20601
Analyte	Unit	Method				
Total Dissolved Solids @ 180C	mg/L	1001G	4600	4600	0.0	66
Conductivity at 25C	uS/cm	COND-M	8100	8000	1.2	1.2
pH		PH	6.6	6.6	0.0	8.8
Total Alkalinity as CaCO3	mg/L	ALK	51	52	1.9	<1
Bicarbonate Alkalinity as CaCO3	mg/L	ALK	51	52	1.9	<1
Carbonate Alkalinity as CaCO3	mg/L	ALK	0	0	0.0	<1
Hydroxide Alkalinity as CaCO3	mg/L	ALK	0	0	0.0	<1
Sulphate as SO4	mg/L	SO4	360	360	0.0	<2
Ammonia Nitrogen as N	mg/L	NH3-LL-DA	<0.004	<0.004	0.0	<0.004
Nitrate Nitrogen as N	mg/L	TON-HR-DA	4.0	4.0	0.0	<0.005
Nitrite Nitrogen as N	mg/L	TON-HR-DA	0.12	0.12	0.0	<0.001
Orthophosphate as P	mg/L	ORTP-LL-DA	<0.004	<0.004	0.0	<0.004
Chloride as Cl	mg/L	CHLORIDE	2300	2300	0.0	<1
Fluoride as F	mg/L	FLUORIDE	0.31	0.31	0.0	<0.1
Calcium as Ca	mg/L	CATIONS	120	110	8.7	0.06
Magnesium as Mg	mg/L	CATIONS	140	140	0.0	<0.02
Sodium as Na	mg/L	CATIONS	1300	1300	0.0	<0.02
Potassium as K	mg/L	CATIONS	13	13	0.0	<0.02
Total Aluminium as Al	mg/L	ECO-METALS	<0.01	<0.01	0.0	<0.01
Total Antimony as Sb	mg/L	ECO-METALS	<0.001	<0.001	0.0	<0.001
Total Arsenic as As	mg/L	ECO-METALS	0.001	0.001	0.0	<0.001
Total Barium as Ba	mg/L	ECO-METALS	0.072	0.070	2.8	<0.001
Total Beryllium as Be	mg/L	ECO-METALS	<0.001	<0.001	0.0	<0.001
Total Boron as B	mg/L	ECO-METALS	0.35	0.34	2.9	<0.02
Total Cadmium as Cd	mg/L	ECO-METALS	<0.0002	<0.0002	0.0	<0.0002
Total Chromium as Cr	mg/L	ECO-METALS	<0.001	<0.001	0.0	<0.001
Total Cobalt as Co	mg/L	ECO-METALS	0.004	0.004	0.0	<0.001
Total Copper as Cu	mg/L	ECO-METALS	<0.001	<0.001	0.0	<0.001
Total Iron as Fe	mg/L	ECO-METALS	0.01	0.01	0.0	<0.01
Total Lead as Pb	mg/L	ECO-METALS	<0.001	<0.001	0.0	<0.001
Total Manganese as Mn	mg/L	ECO-METALS	0.056	0.053	5.5	<0.001
Total Molybdenum as Mo	mg/L	ECO-METALS	<0.001	<0.001	0.0	<0.001
Total Nickel as Ni	mg/L	ECO-METALS	0.005	0.004	22.2	<0.001
Total Selenium as Se	mg/L	ECO-METALS	0.011	0.011	0.0	<0.001
Total Silver as Ag	mg/L	ECO-METALS	<0.001	<0.001	0.0	<0.001
Total Strontium as Sr	mg/L	ECO-METALS	1.4	1.4	0.0	<0.001
Total Thallium as Tl	mg/L	ECO-METALS	<0.001	<0.001	0.0	<0.001
Total Thorium as Th	mg/L	ECO-METALS	<0.002	<0.002	0.0	<0.002
Total Tin as Sn	mg/L	ECO-METALS	0.001	0.001	0.0	<0.001
Total Titanium as Ti	mg/L	ECO-METALS	<0.001	<0.001	0.0	<0.001
Total Uranium as U	mg/L	ECO-METALS	<0.001	<0.001	0.0	<0.001
Total Vanadium as V	mg/L	ECO-METALS	0.003	0.003	0.0	0.003
Total Zinc as Zn	mg/L	ECO-METALS	0.016	0.015	6.5	<0.001
Total Mercury as Hg	mg/L	ECO-METALS	<0.0001	<0.0001	0.0	<0.0001

APPENDIX A

IWMP Performance Report Audit

Table 2: IWMP Performance Report Audit

Source & Requirement	Observations	Compliance	Recommendations
<p>Planning Permit Clause 14. Within 90 days of the commencement of this permit operating, an Incoming Waste Monitoring Plan (IWMP) must be submitted to the satisfaction of the responsible authority and the Department of Health and Human Services for approval by the responsible authority. Three copies of the IWMP must be submitted to the responsible authority. When approved by the responsible authority the IWMP will be endorsed and it will then form part of this permit. The IWMP must provide for:</p>		Compliant	
<p>a) A monitoring and reporting system for ensuring that materials disposed of to Pit 23 are limited to those permitted under the conditions of this permit</p>	<p>Section 3.1 of the IWMP Performance Report provides a spreadsheet summary record stating material to be disposed of is permitted.</p> <p>No waste was disposed to Pit 23 during the H2 2020 reporting period.</p>	Compliant	
<p>b) Recording the origin, per load weight and radioactive properties of each incoming load.</p>	<p>Section 3.1 of the IWMP Performance Report provides a spreadsheet summary recording the origin and load weight of each material load.</p> <p>Section 3.2 of the IWMP Performance Report provides a summary of the radioactive properties of each material load.</p>	Compliant	

Source & Requirement	Observations	Compliance	Recommendations
c) Monitoring to ensure all vehicles transporting waste have fully secured and contained loads and that all waste loads have been transported in compliance with licensed requirements under the Radiation Act 2005;	<i>Work instruction for Loading of Monazite and Ilmenite CL product at the Iluka MSP- Hamilton site identifies that loads are to be secured and contained.</i>	Compliant	
d) Records of any transport incidents or spills and remedial actions taken in the event of such incidents.	Section 3.3.1 of the IWMP Performance Report states that no transport incidents or spillages occurred over H2 2020 period.	Compliant	
e) Annual auditing of records to verify compliance with the requirements of the IWMP	This audit fulfils this requirement.	Compliant	
Amendments to the IWMP must be to the satisfaction of the responsible authority and Department of Health and Human Services and must only be made on written approval of the responsible authority.		NA	
IWMP Section 2 Acceptance Criteria			
Source Site. Disposal into Pit 23 is restricted to materials from the following source sites; <ul style="list-style-type: none"> ■ the Hamilton MSP; ■ the Douglas mineral sands mine; ■ the Kulwin mineral sands mine site (located 28 kilometres east of Ouyen); 	Section 3.1 of the IWMP Performance Report states that no material was disposed into Pit 23 during the H2 2020 reporting period.	Compliant	

Source & Requirement	Observations	Compliance	Recommendations
<ul style="list-style-type: none"> ■ the Woonack Rownack and Pirro mineral sands mine site (located 20 km southwest of Ouyen); ■ Facilities operated by transport contractors associated with the Port of Portland including the heavy mineral concentrate (HMC) storage and train loading facilities at Hopetoun; and ■ storage facilities in Portland used for storage of the Hamilton MSP products 			
<p>Radioactivity. Disposal to Pit 23 is restricted to materials that contain and are contaminated with naturally occurring radioactive material (NORM), which are:</p> <ul style="list-style-type: none"> ■ mineral by-products from the Hamilton MSP, including gypsum produced at the MSP; ■ used Bag-house dust filter bags (used filter bags); and ■ concrete or steel from the sites listed in Section 2.1 above. 	<p>Section 3.2 of the IWMP Performance Report provides a summary of the radioactive properties of each material load.</p> <p>Section 3.1 of the IWMP Performance Report states that no material was disposed into Pit 23 during the H2 2020 reporting period.</p>	Compliant	
<p>By-products for disposal. The Hamilton MSP by-products to disposed into Pit 23 are;</p> <ul style="list-style-type: none"> ■ Wet circuit rejects ■ Dry circuit rejects; ■ Gypsum 	<p>Section 3.1 of the IWMP Performance Report states that no material was disposed into Pit 23 during the H2 2020 reporting period.</p>	Compliant	

Source & Requirement	Observations	Compliance	Recommendations
<ul style="list-style-type: none"> ■ Bag hose dust filter bags ■ Contaminated concrete and steel 			
<p>Material Description and physical form. Import for disposal into Pit 23 is restricted to the following materials:</p> <ul style="list-style-type: none"> ■ non-liquid waste by-products associated with or sourced through mineral sands processing undertaken at the Hamilton MSP containing or contaminated with NORM; ■ used dust filter bags from the Hamilton MSP containing or contaminated with NORM; and ■ NORM-contaminated concrete and steel associated with plant and infrastructure from the sites listed in Section 2.1 above 	<p>Section 3.1 of the IWMP Performance Report states that no material was disposed into Pit 23 during the H2 2020 reporting period.</p>	Compliant	
<p>IWMP Section 3. Monitoring</p>			
<p>In accordance with heavy vehicle mass management requirements under Chain of Responsibility legislation administered by the Department of Economic Development, Jobs, Transport and Resources (DEDJTR), the weight of every truck load of material to be disposed of will be measured at the point of loading, or the nearest possible location, prior to transport to the Douglas mine site. The load weight shall be measured by one of the following means;</p>	<p>Section 3.1 of the IWMP Performance Report lists the load weight of each delivery to Pit23. During the H2 2020 reporting period, no material was disposed to Pit 23.</p> <p>Iluka has advised that a public commercial calibrated weighbridge is used to weigh material disposed into Pit23.</p>	Compliant	

Source & Requirement	Observations	Compliance	Recommendations
<ul style="list-style-type: none"> ■ calibrated weighbridge ■ calibrated on-board weighing systems (such as airbag weightometers) ■ any other mass measurement system or methodology approved by the DEDJTR for demonstrating compliance with heavy vehicle mass management requirement 			
<p>For each individual load, the following information shall be recorded in an electronic data management system:</p> <ul style="list-style-type: none"> ■ load weight ■ material description ■ radioactive properties, being <ul style="list-style-type: none"> ■ concentrations of uranium and thorium in MSP by-products based on the weekly average of the by products produced ■ measured concentrations of uranium and thorium in used filter bags, concrete and steel 	<p>Section 3.1 of the IWMP Performance Report provides information on load weight and material description.</p> <p>Section 3.2 of the IWMP Performance Report provides a summary of the radioactive properties of each material load.</p> <p>During the H2 2020 reporting period, no material was disposed to Pit 23.</p>	<p>Compliant</p>	
<p>IWMP Section 4 Control of access for disposal</p>			

Source & Requirement	Observations	Compliance	Recommendations
<p>Prior to transport of materials to be disposed of in Pit 23, vehicles will be checked:</p> <ul style="list-style-type: none"> ■ for compliance with the ARPANSA Code of Practice for Safe Transport of Radioactive Material; and ■ to confirm and ensure loads are fully secured and contained. <p>Deliveries must enter the site via Elliotts Road and the mine access road shown on the site plan (Figure 2).</p> <p>All vehicles entering the site, including those carrying materials for disposal to Pit 23, must be authorised and must pass through a boom gate that may only be opened with a swipe card issued to authorised personnel or by an authorised Iluka employee at the site office. Each vehicle must then stop at the site office to:</p> <ul style="list-style-type: none"> ■ provide a record of the load being delivered (origin, material type, load weight); and ■ comply with any site-specific requirements that apply for entering the site. <p>Vehicles carrying materials for disposal for which the required information is not provided or is not in conformance with the permitted use will not be allowed to dispose of their loads to Pit 23.</p>	<p>Work instruction for <i>Loading of Monazite and Ilmenite CL product at the Iluka MSP- Hamilton site</i> reviewed. Deliveries were not observed as part of this audit.</p> <p>Furthermore, during the H2 2020 reporting period, no material was disposed to Pit 23.</p>	<p>NA</p>	

Source & Requirement	Observations	Compliance	Recommendations																											
<p>IWMP Section 5 Monitoring Program</p> <p>In order to confirm the presence of NORM within the MSP by-products, Table 2 in the IWMP specifies the samples collected and quantity measurements made:</p> <p>Table 2: MSP by-product sampling and quantity measurement</p> <table border="1" data-bbox="159 544 837 1066"> <thead> <tr> <th></th> <th>Sampling Method</th> <th>Quantity</th> </tr> </thead> <tbody> <tr> <td colspan="3">Wet Circuits Rejects</td> </tr> <tr> <td>FPC Sand Tailing</td> <td>Automatic Sampler within plant producing daily composite from frequent cuts</td> <td>Continuous flow and density measurement to provide daily solids tonnage</td> </tr> <tr> <td>FPC Fines</td> <td>Manual sample from thickener underflow collected daily</td> <td>Continuous density measurement and volume measurement from positive displacement pump operation to provide daily solids tonnage</td> </tr> <tr> <td>ZWC Sand Tailings</td> <td>Automatic Sampler within plant producing daily composite from frequent cuts</td> <td>Continuous flow and density measurement to provide daily solids tonnage</td> </tr> <tr> <td colspan="3">Dry Circuits Rejects</td> </tr> <tr> <td>PDC Non-Conductor magnetics</td> <td>Automatic Sampler within plant producing daily composite from frequent cuts</td> <td>Weightometer integrated to provide daily tonnage.</td> </tr> <tr> <td>DCC Magnetics</td> <td>Automatic Sampler within plant producing daily composite from frequent cuts</td> <td>Weightometer integrated to provide daily tonnage.</td> </tr> <tr> <td>Gypsum</td> <td>Manual sample from bunker collected daily</td> <td>Continuous density measurement and volume measurement from positive displacement pump operation to provide daily solids tonnage</td> </tr> </tbody> </table>		Sampling Method	Quantity	Wet Circuits Rejects			FPC Sand Tailing	Automatic Sampler within plant producing daily composite from frequent cuts	Continuous flow and density measurement to provide daily solids tonnage	FPC Fines	Manual sample from thickener underflow collected daily	Continuous density measurement and volume measurement from positive displacement pump operation to provide daily solids tonnage	ZWC Sand Tailings	Automatic Sampler within plant producing daily composite from frequent cuts	Continuous flow and density measurement to provide daily solids tonnage	Dry Circuits Rejects			PDC Non-Conductor magnetics	Automatic Sampler within plant producing daily composite from frequent cuts	Weightometer integrated to provide daily tonnage.	DCC Magnetics	Automatic Sampler within plant producing daily composite from frequent cuts	Weightometer integrated to provide daily tonnage.	Gypsum	Manual sample from bunker collected daily	Continuous density measurement and volume measurement from positive displacement pump operation to provide daily solids tonnage	<p>The MSP was not operating during H2 2020, so no data was available.</p>	<p>NA</p>	
	Sampling Method	Quantity																												
Wet Circuits Rejects																														
FPC Sand Tailing	Automatic Sampler within plant producing daily composite from frequent cuts	Continuous flow and density measurement to provide daily solids tonnage																												
FPC Fines	Manual sample from thickener underflow collected daily	Continuous density measurement and volume measurement from positive displacement pump operation to provide daily solids tonnage																												
ZWC Sand Tailings	Automatic Sampler within plant producing daily composite from frequent cuts	Continuous flow and density measurement to provide daily solids tonnage																												
Dry Circuits Rejects																														
PDC Non-Conductor magnetics	Automatic Sampler within plant producing daily composite from frequent cuts	Weightometer integrated to provide daily tonnage.																												
DCC Magnetics	Automatic Sampler within plant producing daily composite from frequent cuts	Weightometer integrated to provide daily tonnage.																												
Gypsum	Manual sample from bunker collected daily	Continuous density measurement and volume measurement from positive displacement pump operation to provide daily solids tonnage																												
<p>Bag-house dust filter bags.</p> <p>Prior to transport, sections of used filter bag cloth of approximately 100 x 100 mm will be cut from at least five used filter bags per consignment and each section submitted for analysis</p>	<p>The MSP was not operating during H2 2020 and the IWMP Performance Report did not identify that filter bags were disposed of during H2 2020, so no data was available.</p>	<p>NA</p>																												

Source & Requirement	Observations	Compliance	Recommendations
<p>NORM contaminated concrete and steel.</p> <p>The sampling method applied will be dependent on the precise nature of the material and will be developed and applied on a case-by-case basis. Representative samples of each consignment will be collected and submitted for analysis</p>	<p>The MSP was not operating during H2 2020 and the IWMP Performance Report did not identify that concrete and steel were disposed of during H2 2020, so no data was available.</p>	<p>NA</p>	
<p>Mineral separation plant by-products. Analysis of MSP by-products is undertaken as follows:</p> <ul style="list-style-type: none"> ■ desiccation within the MSP laboratory oven to remove moisture; ■ pulverisation (as required) to produce a fine granular matrix; ■ splitting to produce a representative sample of appropriate size; ■ fusion of the sample to produce a glass bead; and ■ assay of the bead using an X-Ray Fluorescence Spectrophotometer to determine the concentrations of uranium and thorium. <p>The assay results are uploaded into Iluka's production statistics database as are the results of tonnage measurements of the various streams. The data is then used to calculate the uranium and thorium concentrations in each of the wet circuits rejects, dry circuits rejects and gypsum.</p>	<p>Analytical procedures were provided and reviewed.</p>	<p>Compliant</p>	

Source & Requirement	Observations	Compliance	Recommendations
Analysis of filter bag samples will be undertaken at either Iluka's Hamilton laboratory or an external laboratory to determine the concentrations of uranium and thorium.	Section 3.1 of the IWMP Performance Report states no filter bags were disposed of to Pit 23 during H2 2020 reporting period.	NA	
Samples of NORM contaminated concrete and steel will be analysed at either Iluka's MSP lab or an external laboratory to determine the concentrations of uranium and thorium.	Section 3.1 of the IWMP Performance Report states no concrete or steel was disposed of into Pit 23 during H2 2020 reporting period.	NA	
IWMP Reporting			
All data generated from the monitoring described above will be recorded electronically in a data base managed by Iluka. On an annual basis a report will be prepared showing the following:			
For each load: <ul style="list-style-type: none"> ■ Source site ■ Load weight ■ Radioactive properties being: <ul style="list-style-type: none"> ■ assigned concentration of uranium and thorium in MSP mineral byproducts, based on weekly averages of by-products produced; and ■ measured concentrations of uranium and thorium in used filter bags, concrete or steel. 	Section 3.1 and 3.2 of the IWMP Performance report provides the source, weight and radioactive properties of the received material. During the H2 2020 reporting period, no material was disposed into Pit 23.	Compliant	

Source & Requirement	Observations	Compliance	Recommendations
<p>For the report period:</p> <ul style="list-style-type: none"> ■ average concentration of uranium and thorium for the MSP by-products, used filter bags, concrete and steel; ■ total quantities of materials disposed of to Pit 23; and ■ records of any transport incidents or spills and remedial actions taken in the event of such incidents. 	<p>Section 3.2 of the IWMP Performance Report provides information on the radioactivity analysis of MSP by-products disposed.</p> <p>Section 3.3 of the IWMP Performance Report states no transport incidents or spillages occurred during the reporting period.</p>	Compliant	
<p>The Performance Report will be provided to a suitably qualified auditor who will complete an audit of the data provided and compliance with this IWMP.</p>	<p>This report is provided in accordance with the requirement of the IWMP.</p>	Compliant	
<p>Copies of the Performance Report and the audit report will be submitted to the Responsible Authority.</p>	<p>As the Auditor understands that Iluka will submit the performance reports and the audit report when complete, compliance with this requirement cannot be verified. Iluka has advised that the previous performance report has been submitted to Council.</p>	Compliant	
<p>IWMP Review</p>			
<p>This IWMP shall be reviewed and amended if necessary, to take account of:</p> <ul style="list-style-type: none"> ■ advances in knowledge and technology pertaining to by-product disposal; included in this report. ■ any significant change in operations; ■ changes in applicable legislation or standards; 		Compliant	

Source & Requirement	Observations	Compliance	Recommendations
<ul style="list-style-type: none"> ■ changes in Iluka’s EHS standards; or every two (2) years, which-ever occurs soonest. 			
<p>Proposals for amendment of this plan will be prepared to the satisfaction of the Responsible Authority and the Department of Health and Human Services.</p>	<p>No amendments to the IWMP have been submitted in H2 2020. A review and update of the IWMP is has been undertaken and is anticipated to be submitted to the Relevant Authority in H1 2021.</p>	<p>Compliant</p>	

APPENDIX B

**EMP & RVMP Performance
Report Audit**

Table 3: EMP Performance Report Audit

Requirement	Observations	Compliance	Recommendations
EMP Section 12.2			
A review of performance will be completed and an EMP and Rehabilitation Performance Report prepared annually, or less frequently as may be agreed with the Responsible Authority.	The Environmental Management Plan and Rehabilitation Performance Report has been prepared for H2 2020. Section 2.5 of the EMP Performance Report states that due to continued operations within Pit 23, no actions relevant to rehabilitation and vegetation management were undertaken in the H2 2020 reporting period.	Compliant	
Each EMP and Rehabilitation Performance Report will include for the period from the previous EMP and Rehabilitation Performance Report:			
<ul style="list-style-type: none"> ■ the total tonnage of materials disposed of; 	Section 3 of the EMP Performance Report states that no wastes were disposed into Pit 23 during the H2 2020 reporting period.	Compliant	
<ul style="list-style-type: none"> ■ the average and maximum number of deliveries of materials for disposal per day; and 	Section 3 of the EMP Performance Report states that no wastes were disposed into Pit 23 during the H2 2020 reporting period.	Compliant	
<ul style="list-style-type: none"> ■ the results of all measurements of: 			
<ul style="list-style-type: none"> <ul style="list-style-type: none"> ■ noise levels made in response to a complaint regarding noise; 	Section 4.3 of the EMP Performance Report states that because complaints regarding noise levels have not been	Compliant	

Requirement	Observations	Compliance	Recommendations
	<p>made, noise monitoring as not been undertaken, as outlined by Section 10.1.4. of the EMP.</p>		
<ul style="list-style-type: none"> ▪ PM₁₀ concentrations in air at sensitive receptors; 	<p>Section 4.4 of the EMP Performance Report outlines the results of the PM₁₀ monitoring program that was undertaken in H2 2020. During the reporting period, there were two exceedances of the PM₁₀ concentration limit on the 12th and 30th December 2020.</p> <p>The H2 2020 Performance Report concluded that the observed exceedances were not associated with Pit 23 activity, due to the prevailing wind direction and the monitoring station association matrix, presented in Table 9. The Auditor agrees with this assessment.</p>	Compliant	
<ul style="list-style-type: none"> ▪ the results of all measurements of groundwater level and quality; 	<p>Groundwater monitoring results are included in Section 4.1. Monitoring locations and frequency were compliant with Table 7 of EMP. Wells requiring six-monthly gauging were gauged in July 2021. Wells requiring monthly gauging were gauged in each month of the reporting period. Well BW36A was substituted for the decommissioned BW36. The new well GW04A was included in monitoring from November 2020.</p> <p>Groundwater quality field parameters are required by the EMP to be collected at the same frequency as water level gauging. These results are presented in Appendix C: it appears that the required frequency was met.</p> <p>Six-monthly sampling and laboratory analysis is required by the EMP. This was conducted in July 2020, with additional</p>	Compliant	<p>QAQC sampling should be included as part of each sampling round and evidence of data quality validation of field and laboratory QAQC results reported in the annual performance report.</p> <p>Changes to EMP trigger values and contingencies adopted in EMP (Rev 5.1)</p>

Requirement	Observations	Compliance	Recommendations
	<p>sampling at some locations to follow up trigger actions. Laboratory reports from EML Chem and ALS were supplied, which demonstrate NATA or equivalent accreditation. The EMP (Section 7.6.8) requires analysis of QAQC samples as part of each sampling round including field duplicates and blank samples. Iluka has advised that the collection of QAQC samples resumed in the November 2020 sampling round. A laboratory report with a duplicate sample and a blank sample was supplied for samples collected in November 2020. Analysis for these samples was completed for metals, nutrients and major ions, but analysis for radionuclides was not reported.</p> <p>The Auditor has assessed the relative percentage difference between the primary sample and duplicate sample (Table A attached). This indicates acceptable laboratory precision based on the supplied results. The results of the field blank sample indicated detectable concentrations of TDS (66 mg/L), calcium (0.06 mg/L) and vanadium (0.003 mg/L). However, these concentrations are close to the respective laboratory limits of reporting and orders of magnitude lower than results from primary samples (for TDS and calcium) or similar to results from primary samples (vanadium), so do not indicate gross cross-contamination.</p> <p>Comparison of Cl:SO₄ and Na:Ca ratios were made as required in the EMP. A decrease of more than 10% compared to the previous six-monthly sample is a trigger for</p>		<p>should apply for monitoring from 2021.</p>

Requirement	Observations	Compliance	Recommendations
	<p>further investigation. Decreases of more than 10% were reported for five samples for Cl:SO₄ (BW36A, BW53, GW01, GW02, GW04) and three for Na:Ca (WRK302, WRK303, WRK304), however, on repeat sampling in August 2020 or September 2020 only BW36A (down-gradient) and GW04 (cross-gradient) confirmed more than 10% decrease in Cl:SO₄ ratio and only WRK304 (up-gradient) was confirmed for Na:Ca ratio. The absolute concentration changes were relatively small.</p> <p>These ratio changes triggered an assessment of other parameters against concentration-based trigger levels. This indicated only selenium concentrations at GW04 in July 2020, August 2020 and October 2020 were above the precautionary trigger level (85% of ANZECC guideline). An assessment of background conditions at GW04 was made based on previous results, indicating background concentrations above the trigger levels. It was concluded that the changes in groundwater chemistry discussed were unlikely to be related to seepage from Pit 23, particularly as GW04 is inferred to be located across hydraulic gradient from Pit 23.</p> <p>Surface water monitoring results are included in Section 4.2. Surface water sampling is required on a quarterly basis, if water is present, with additional sampling following off-site run-off events. There were no off-site discharges of stormwater reported, so additional sampling of off-site run-off monitoring sites was not required. Three surface water</p>		

Requirement	Observations	Compliance	Recommendations
	<p>monitoring sites inferred to be along the groundwater flow path from Pit 23 (SW5B, SW20, SW24) were sampled in September 2020 and October 2020, but were dry in June 2020 or July 2020. Two reference sites not on the inferred groundwater flow path (SW22, SW14) were sampled in July 2020 and October 2020. Locations SW11, SW19, SW25, SW27 were sampled in October 2020, and SW19 was also sampled in November 2020.</p> <p>The table in EMP Revision 4 which summarises the surface water monitoring program (Table 15) lists 14 locations for quarterly monitoring, five of which include major ion analysis. Iluka advise that surface water locations were dry at the remaining scheduled sampling times not reported.</p> <p>Ionic ratios for the sampled locations did not indicate greater than 10% decreases from the previous results, except for SW22 (Shaw's Gully). At SW22 the Na:Ca ratio in October 2020 was 20% lower than in July 2020. However, as this location is a reference site not on the inferred flow path for surface water or groundwater from the Pit 23 area, no further action was required.</p>		
<ul style="list-style-type: none"> ▪ the results of and actions taken in response to monitoring bore audits; 	<p>All bores were reported to be in serviceable condition, with BW36 replaced by BW36A in 2019.</p>	<p>Compliant</p>	
<ul style="list-style-type: none"> ▪ environmental radiation monitoring results in accordance with the approved 			

Requirement	Observations	Compliance	Recommendations
Radiation Management Plan, which will generally include:			
<ul style="list-style-type: none"> - radon concentration in air; 	Results for Radon and Thoron monitoring in air were reported in Section 4.5.1 and did not exceed the reportable level during the reporting period. Sampling program is compliant with the Radiation Management Plan monitoring program (Section 9).	Compliant	
<ul style="list-style-type: none"> - gross alpha activity concentration of airborne dust; and 	<p>Gross alpha activity results were reported in Section 4.5.2. A peak value of 0.228 mBq/m³ was recorded at Chadwick's on 7 September 2020, which is in line with historical values.</p> <p>Sampling program is compliant with the Radiation Management Plan monitoring program (Section 9).</p>	Compliant	
<ul style="list-style-type: none"> - radionuclide concentrations in groundwater and surface water 	Groundwater radionuclide monitoring results were reported in Section 4.1.3.2. Of the radionuclide concentrations analysed, U ²³⁸ exceeded the upper trigger level at GW06 and GW03 and exceeded the precautionary trigger at BW45B in July 2020. Repeat sampling in August 2020 at BW45B and in January 2021 at GW03 indicated concentrations below the trigger levels. GW06 was resampled in January 2021, however, results were not available when the report was issued. Ra ²²⁸ exceeded the upper trigger level at one location (BW45B) during the reporting period. This was	Compliant	

Requirement	Observations	Compliance	Recommendations
	<p>confirmed by resampling in August 2020. Bore BW45B is located cross-hydraulic gradient from Pit 23, and has reported similar Ra²²⁸ concentrations at each monitoring event since 2019. Bore GW06 is located up-hydraulic gradient from Pit 23, and has reported similar U238 concentrations since 2019. Repeated radionuclide trigger exceedances were not correlated with changes in major ion ratios, and were not reported for down-gradient bores, so are unlikely to be related to seepage from Pit 23.</p> <p>Surface water radionuclide monitoring results were reported in Section 4.2.2.2. There was no exceedance of trigger levels for uranium or radium in surface water samples.</p>		
<ul style="list-style-type: none"> ▪ discussion of any implications of the results of groundwater level monitoring on groundwater flow paths from Pit 23; and 	<p>Inferred groundwater elevation contours from the reporting period (H2 2020) were not presented, with the June 2020 contours included from the H1 2020 Performance Report. The discussion of groundwater flow direction in Section 5.2 is based on the H1 2020 contours, which are not directly relevant to the reporting period. However, the hydrographs in Section 4.1.2 of the report support that groundwater levels are broadly consistent with previous monitoring. Figure 6 indicates that the water level at wells IWB6 has usually been higher than at BW53, however this was reversed at times during 2019 and 2020. This is not consistent with gauging results in Table 2, where IWB6 remained higher than BW53.</p>	<p>Compliant</p>	<p>The EMP (Section 7.9.1) requires Iluka to construct groundwater contours for each monthly gauging round. At least one of these interpretations should be supplied as part of the Performance Report.</p>

Requirement	Observations	Compliance	Recommendations
<ul style="list-style-type: none"> ▪ descriptions of any model review and recalibration completed and the results of subsequent model reruns; 	<p>An update to the groundwater model was released in September 2019 (EMM, 2019), including water level monitoring results from March 2019. Groundwater levels and inferred hydraulic conductivity from newly installed wells were broadly consistent with the values used in the model in the area of Pit 23. Monitoring results reported do not trigger a requirement for a further update of the groundwater model.</p>	<p>Compliant</p>	
<ul style="list-style-type: none"> ■ the maximum elevation of the upper surface of materials disposed of at the end of the reporting period 	<p>Included in Section 5.4 of the EMP Performance Report. As no waste was disposed during the H2 2020 reporting period, the maximum elevation remains unchanged at 193 m AHD.</p>	<p>Compliant</p>	
<ul style="list-style-type: none"> ■ a detailed discussion of all non-compliant events including progress toward resolution; 	<p>Section 5.5 of the Performance Report states that there were no non-compliances during the reporting period. This is consistent with the monitoring results discussed above.</p>	<p>Compliant</p>	
<ul style="list-style-type: none"> ■ a summary of comments and complaints received and resulting actions; 	<p>Section 5.6 of the EMP Performance Report states that no complaints or comments were received during the H2 2020 reporting period.</p>	<p>Compliant</p>	
<ul style="list-style-type: none"> ■ completed actions from the previous year 	<p>Section 5.7 outlines three completed actions from the previous reporting period:</p> <ul style="list-style-type: none"> ■ Submission of the updated Pit 23 IWMP and EMP as required by the default two-year review period. ■ Annual review of the Risk Analysis and Response Plan (RARP) as per section 6 of the EMP. <p>Installation of groundwater monitoring bore GW04A located between GW04 and BW36A.</p>	<p>Compliant</p>	

Requirement	Observations	Compliance	Recommendations
<ul style="list-style-type: none"> plans for the next reporting period; and 	<p>This is addressed in Section 5.8 of the EMP Performance Report, and includes:</p> <p>Implementation of the ongoing monitoring requirements as per the EMP.</p>	Compliant	
<ul style="list-style-type: none"> discussion on other matters considered relevant by the Responsible Authority or Iluka. 	<p>Section 5.9.1 of the EMP Performance Report confirms that the geotechnical audit for 2020 was completed in December 2020. The next geotechnical audit is scheduled for November 2021.</p> <p>Section 5.9.2 states that the review of the Risk Analysis Response Plan (RARP) was undertaken in November 2020. The next review is scheduled for November 2021.</p>	Compliant	
<p>Deficiencies identified in an EMP and Rehabilitation Performance Report that can be addressed without amendment of this plan will be addressed as soon as practicable.</p>	<p>There was no section discussing this in the Performance Report. The auditor notes that the EMP, IWMP and RVMP have been updated in 2020, where deficiencies were addressed.</p>	Compliant	
<p>EMP and Rehabilitation Performance Reports will be subject to review by an independent auditor as described in Section 13.2 of the EMP (Performance Review).</p>	<p>This audit report addresses the requirement.</p>	Compliant	
<p>EMP Section 13.2 Performance Review</p>			

Requirement	Observations	Compliance	Recommendations
<p>The performance review function is, in part, an audit function in that the selected auditor will be required to audit EMP and Rehabilitation Performance Report to confirm its completeness and accuracy in terms of compliance of the implementation of the plan and compliance with established standards and limits. In addition to these audit functions the selected auditor will be invited to recommend amendments to the EMP to ensure future compliance.</p>	<p>This audit report addresses the requirement.</p>	<p>Compliant</p>	
<p>There are a number of requirements of the expert in this case, including:</p> <ul style="list-style-type: none"> · EPA auditor accreditation; · independence (from Iluka); · suitable qualifications; · expertise in risk management plans in the context of mines and quarries; and · to the satisfaction of the Responsible Authority. <p>It is extremely unlikely that an expert meeting all of these requirements exist, however, an expert may choose to direct the work of others. A scope of works will be prepared and a number of EPA accredited auditors asked to submit proposals for the completion of performance reviews. Iluka will</p>	<p>Iluka has selected Bruce Dawson to undertake the audit as a suitably qualified Auditor appointed under the Environment Protection Act 1970. More information about the auditor is included in Section 3.0 of this report.</p>	<p>Compliant</p>	

Requirement	Observations	Compliance	Recommendations
select the best candidate and provide the Responsible Authority with details of the candidate and their proposal for completion of works. The Responsible Authority may indicate its agreement with the candidate selected or request that details of an alternative be provided.			
A copy of the selected auditor's report will be provided to the Responsible Authority with each EMP Performance Report.	As the Auditor understands that Iluka will submit the performance reports and the audit report when complete, compliance with this requirement cannot be verified.	NA	
Any deficiencies identified or recommendations made by the auditor will be dealt with in accordance with Conditions 44 and 45 of the Permit, which require:			
<ul style="list-style-type: none"> ■ Copies of the EMP and Rehabilitation Performance Report and the auditor's report to be provided to the Responsible Authority with 28 days of receipt of the auditor's report 	As the Auditor understands that Iluka will submit the performance reports and the audit report when complete, compliance with this requirement cannot be verified.	NA	
<ul style="list-style-type: none"> ■ A description of steps to be taken, including timeframes, to address any non-compliance and recommendations identified in the EMP and Rehabilitation Performance Report and the auditor's report be provided to the Responsible Authority within 28 days of submission of the EMP and Rehabilitation 	As the Auditor understands that Iluka will submit the performance reports and the audit report when complete, compliance with this requirement cannot be verified.	NA	

Requirement	Observations	Compliance	Recommendations
Performance Report to the Responsible Authority; and			
<ul style="list-style-type: none"> ■ The Responsible Authority to determine whether amendment to the EMP or RVMP is required and the timeframe and conditions under which such amendment is to occur. 	EMP and RVMP have recently been reviewed and updated in H2 2020.	NA	The EMP and RVMP have been reviewed by the Auditor and the Auditor understands that they will be adopted for the next reporting period.
Copies of the EMP and Rehabilitation Performance Report and the auditor's report to be provided to the Responsible Authority with 28 days of receipt of the auditor's report	As the Auditor understands that Iluka will submit the performance reports and the audit report when complete, compliance with this requirement cannot be verified.	NA	

APPENDIX C

**Iluka IWMP Performance Report
H2 2020**



Iluka Resources Limited Mineral Sands By-Product Disposal

Planning Permit 15-105

**Crown Allotments 91, 94, 95, 96
Parish of Telangatuk**

Incoming Waste Monitoring Plan Report H2– 2020

Iluka Ref: UDOCS 0090-426461582-2341

Contact:
Ian Williams
Environment Superintendent, Murray Basin
ian.Williams@iluka.com

Document control

Revision	Details of review or changes	Prepared by	Date
0	Final	S. Alexander	8-02-2021

Table of contents

1	EXECUTIVE SUMMARY	3
2	INTRODUCTION.....	4
2.1	PLANNING PERMIT 15-105	4
2.2	COMMENCEMENT OF THE PERMIT	4
2.3	ENDORSED PLANS.....	7
2.4	PERMIT CONDITION REQUIREMENT FOR AN IWMP.....	7
2.5	IWMP REPORTING REQUIREMENTS	7
3	MONITORING RESULTS	9
3.1	PER LOAD MONITORING DATA	9
3.2	REPORTING PERIOD MONITORING DATA	9
3.3	INCIDENTS AND REMEDIAL ACTIONS	9
3.4	OTHER MATTERS	9

List of tables

Table 1: Individual load data for incoming wastes to Pit 23, H2 2020	9
Table 2: Quantities and radioactivity results for disposed MSP by-products, H2 2020.....	9

List of figures

Figure 1: Douglas Mine and Pit 23 Regional Location	5
Figure 2: Pit 23 Location	6

1 Executive Summary

Iluka Resources Limited (Iluka) operates the Pit 23 by-products disposal facility located at the Douglas Mine in the Kanagulk area and within the municipality of the Horsham Rural City. Pursuant to Planning Permit 15-105 issued by Horsham Rural City Council (HRCC), and the subsidiary Pit 23 Incoming Waste Monitoring Plan (IWMP), the Pit 23 facility is approved for the disposal of:

- non-liquid waste by-products associated with or sourced through mineral sands processing undertaken at the Iluka Hamilton Mineral Separation Plant (MSP) containing or contaminated with Naturally Occurring Radioactive Material (NORM);
- used dust filter bags from the Hamilton MSP containing or contaminated with NORM; and
- NORM-contaminated concrete and steel associated with plant and infrastructure from nominated Iluka sites within Victoria.

This report is submitted in accordance with Section 6 of the IWMP and provides a summary of the wastes received into Pit 23 (origin, volumes/weights and radioactive properties) and records of incidents and remedial actions applicable to the reporting period of 1st July 2020 to 31st December 2020.

Key commentary on monitoring outcomes and performance against compliance objectives in the IWMP for the H2 2020 reporting period:

- No waste disposed into Pit 23 in the H2 2020 reporting period; and
- No transport incidents or spillages occurred.

Summary incoming waste data and incident information is provided in Section 3.

2 Introduction

Iluka Resources Limited (Iluka) operates the Pit 23 by-products disposal facility located at the Douglas Mine in the Kanagulk area and within the municipality of the Horsham Rural City (Figure 1 and Figure 2).

Pursuant to Planning Permit 15-105 issued by Horsham Rural City Council (HRCC), and the subsidiary Pit 23 Incoming Waste Monitoring Plan (IWMP), the Pit 23 facility is approved for the disposal of mineral separation by-products and used dust filter bags from the Iluka Hamilton Mineral Separation (MSP) which contain or are contaminated with Naturally Occurring Radioactive Material (NORM), and concrete and steel which contains or is contaminated with NORM associated with plant and infrastructure from nominated Iluka sites within Victoria.

2.1 Planning Permit 15-105

Under the Horsham Planning Scheme the subject land is in the Farming Zone and under the provisions of that zone a permit is required for use and development for Industry (Refuse Disposal). On 25th February 2017 Planning Permit 15-105, (the Permit) was issued by the Horsham Rural City Council as the Responsible Authority to allow:

Use and development of the land for the disposal of waste by-products associated with or sourced through mineral sands processing undertaken at the Hamilton Mineral Separation Plant (MSP), including waste by-products and contaminated materials resulting from the processing and transport operations as follows:

- *By-products from the processing of heavy mineral concentrate at the Hamilton MSP;*
- *used dust filter bags from the Hamilton MSP; and*
- *Other chemically inert material contaminated with naturally occurring radioactive material.*

in accordance with the endorsed plans.

2.2 Commencement of the Permit

Condition 1 of the Permit states:

This permit does not come into operation until:

- a. Iluka has applied to the Department of Economic Development, Jobs, Transport and Resources to vary the 2003 Work Plan to identify a new end uses utilisation of Pit 23 and to vary the rehabilitation plan; and*
- b. Iluka has applied to the Minister to surrender part of MIN 5367¹ (Pit 23); and*
- c. The Department of Economic Development, Jobs, Transport and Resources has approved the Work Plan Variation; and*
- d. The Minister has registered the partial surrender of MIN 5367.*

The permit comes into operation on the same day the Work Plan Variation is approved, and the partial surrender of MIN 5367 is registered.

The Variation to the 2003 Douglas Mine Work Plan was approved on the 13th April 2017, and the partial surrender of MIN 5367 was registered on 11th May 2017, this being the date of commencement of the Permit.

¹ Iluka Resources Douglas Mine – Mining Licence No. 5367 ('MIN 5367')

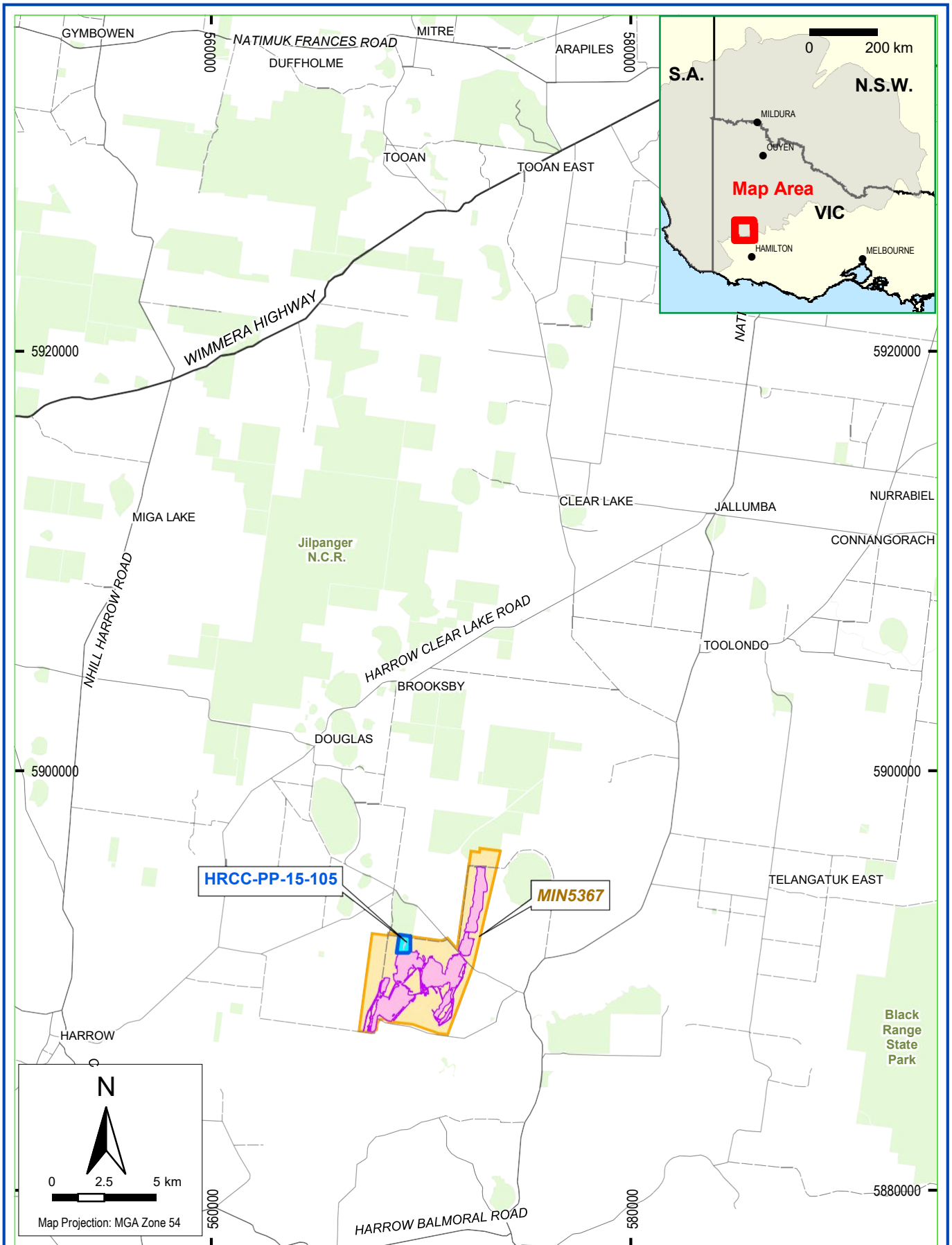

Legend

- Douglas mine
- Pit 23
- HRCC-PP-15-105
- MIN5367 tenement

DOUGLAS
LOCATION PLAN



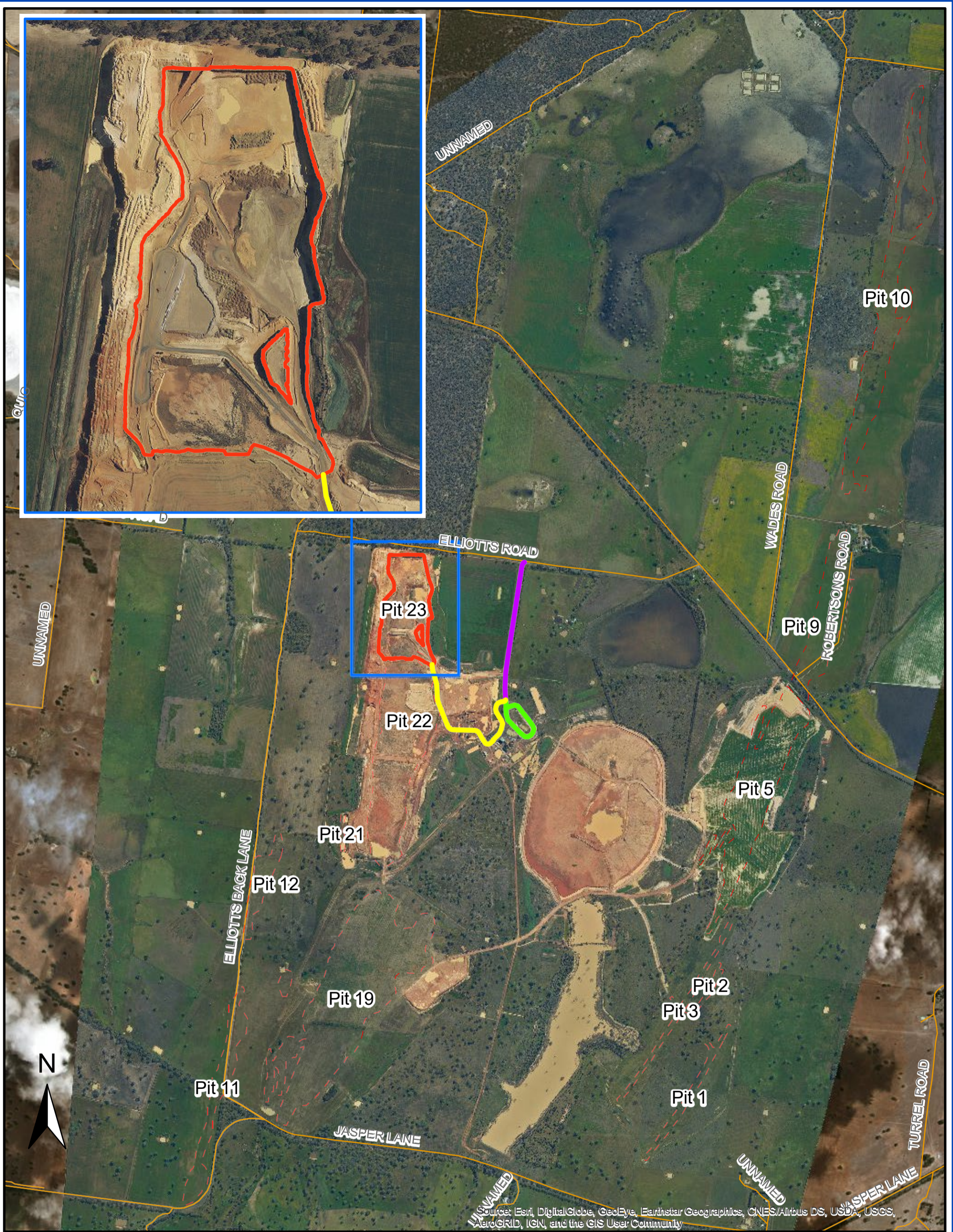

Source: Esri, DigitalGlobe, GeoEye, Earthstar Geographics, CNES/Airbus DS, USDA, USGS, AeroGRID, IGN, and the GIS User Community

Legend

- Pit 23 haul road
- Mine Access Road
- Truck wash circuit
- Pit 23 crest
- Pit Crests
- Roads

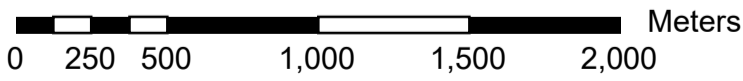

LOCATION OF PIT 23



2.3 Endorsed Plans

Conditions 2, 3, 9, 14, 16 and 34 of the Permit relate to various management plans that once approved by the Responsible Authority will be endorsed to form part of the Permit, which includes:

- Incoming Waste Monitoring Plan (IWMP);
- Environmental Management Plan (EMP), incorporating;
 - Groundwater Monitoring and Management Plan (GWMMP);
 - Surface Water Monitoring and Management Plan (SWMMP);
 - Air Quality/Dust Control Plan (AQMP); and
- Rehabilitation and Vegetation Management Plan (R&VMP)

The plans were endorsed by Horsham Rural City Council on 17th July 2017.

2.4 Permit condition requirement for an IWMP

To ensure compliance with the permitted use (Section 2.1) the Permit includes the following condition concerning the requirement for and content of an IWMP:

Incoming Waste Monitoring Plan

14. Within 90 days of the commencement of this permit operation, an Incoming Waste Management Plan (IWMP) must be prepared to the satisfaction of the Responsible Authority in consultation with the Department of Health and Human Services for the approval by the responsible authority. Three copies of the plan must be provided to the responsible authority. When approved by the responsible authority the IWMP will be endorsed and it will then form part of this permit. The IWMP must provide for

- a) A monitoring and reporting system for ensuring that materials disposed of to Pit 23 are limited to those approved under the conditions of this permit;*
- b) Recording of the origin, per load weight and radioactive properties of each incoming load;*
- c) Monitoring to ensure all vehicles transporting waste have fully secured and contained loads and that all waste loads have been transported in compliance with licence requirements under the Radiation Act 2005;*
- d) Records of any transport incidents or spill and remedial actions taken in the event of such incidents; and*
- e) Annual audits of records to verify compliance with the requirements of the IWMP*

2.5 IWMP reporting requirements

Section 6 of the IWMP states the following reporting requirements:

On an annual basis a report will be provided showing the following:

- *For each load:*
 - *source site;*
 - *load weight; and*
 - *material description; and*
- *For the report period:*
 - *radioactivity of by-products on a monthly basis; and*
 - *total quantities of by-products disposed of to Pit 23.*

The annual report will be provided to a suitably qualified auditor who will complete an audit of the data provided and compliance with this IWMP. Copies of the annual report and the audit report will be submitted to the Responsible Authority

These reporting requirements are addressed in the following sections.

3 Monitoring Results

3.1 Per load monitoring data

In accordance with Section 6 of the endorsed IWMP, data associated with each load of incoming waste is shown in Table 1. No loads of material were received into Pit 23 in the H2 2020 reporting period.

Table 1: Individual load data for incoming wastes to Pit 23, H2 2020

Date	Week No.	Source site	Location Code	Material Code	Load weight (t)

3.2 Reporting period monitoring data

In accordance with Section 6 of the endorsed IWMP, the monthly average radioactivity of by-products shall be reported. However, no by-products were disposed into Pit 23 during the reporting period. No samples required for radionuclide analysis as shown in Table 2.

Table 2: Quantities and radioactivity results for disposed MSP by-products, H2 2020

Product	Product (tonnes)	Th (ppm)	U (ppm)
Dry circuit rejects	0	n/a	n/a
Wet circuit rejects	0	n/a	n/a
Baghouse dust filter bags	0	n/a	n/a
Total	0		

3.3 Incidents and remedial actions

3.3.1 Incidents or spills

No transport incidents or spillages occurred during the reporting period

3.3.2 Remedial actions taken

None required

3.4 Other matters

None identified.

APPENDIX D

**Iluka EMP & IWMP Performance
Report H2 2020**



Iluka Resources Limited Mineral Sands By-Product Disposal

Planning Permit 15-105

**Crown Allotments 91, 94, 95, 96
Parish of Telangatuk**

Environmental Management Plan and Rehabilitation Performance Report – H2 2020

Iluka Ref: UDOCS 0058-1414587248-1098

Contact:
Ian Williams
Environment Superintendent, Murray Basin
ian.williams@iluka.com

Document control

Revision	Details of review or changes	Prepared by	Date created
A	Draft	S. Alexander	10-03-2021
0	Final	S.Alexander	

Table of contents

1	EXECUTIVE SUMMARY	5
2	INTRODUCTION	6
2.1	PLANNING PERMIT 15-105.....	6
2.2	COMMENCEMENT OF THE PERMIT	6
2.3	ENDORSED PLANS.....	9
2.4	PERFORMANCE REPORTING	9
2.5	REHABILITATION AND VEGETATION MANAGEMENT PLAN.....	10
3	DELIVERY AND DISPOSAL OF MATERIALS INTO PIT 23	10
4	MONITORING RESULTS	10
4.1	GROUNDWATER.....	10
4.2	SURFACE WATER QUALITY	36
4.3	NOISE.....	41
4.4	PM ₁₀ CONCENTRATIONS IN AIR	41
4.5	RADIATION MONITORING – OTHER	45
5	MANAGEMENT ACTIONS	49
5.1	MONITORING BORE AUDITS.....	49
5.2	GROUNDWATER FLOW PATHS FROM PIT 23.....	49
5.3	GROUNDWATER MODEL REVIEW AND RECALIBRATION.....	51
5.4	MAXIMUM SURFACE LEVEL OF DISPOSED MATERIALS IN PIT 23	51
5.5	NON-COMPLIANCES	51
5.6	COMMENTS AND COMPLAINTS RECEIVED	51
5.7	H2 2020 COMPLETED ACTIONS.....	51
5.8	H1 2021 PROPOSED ACTIONS.....	52
5.9	OTHER MATTERS	52
6	REFERENCES	53
7	APPENDICES.....	54
	APPENDIX A: MONITORING DATA (LAB) – RADIATION – SURFACE WATER.....	54
	APPENDIX B: MONITORING DATA (LAB) – GROUNDWATER.....	55
	APPENDIX C: MONITORING DATA (FIELD) – GROUNDWATER	116
	APPENDIX D: MONITORING DATA (LAB) – SURFACE WATER	135
	APPENDIX E: MONITORING DATA (FIELD) – SURFACE WATER	152

List of tables

Table 1: Pit 23 bore status (as at 31/12/2020).....	10
Table 2: Monitoring bores - standing water Levels (mAHD).....	13
Table 3: Groundwater monitoring locations – ionic ratio balance results	16
Table 4: Groundwater radionuclide concentrations vs. ionic balance ratios, H2 2020	23
Table 5: Groundwater quality exceedances vs ionic balance ratios, H2 2020	35
Table 6: Selenium groundwater trigger levels for GW04, H2 2020	35
Table 7: Surface water monitoring - ionic ratio balance results	37
Table 8: Monitoring program – radionuclide concentrations in surface water	40
Table 9: Elevated PM10 association with Pit 23 matrix	42
Table 10: PM ₁₀ exceedance assessment, H2 2020.....	43
Table 11: Radon concentrations within Pit 23 for H2 2020.....	46
Table 12: Thoron concentrations within Pit 23 for H2 2020	46
Table 13: Gross Alpha radiation in PM ₁₀ dust	48

List of figures

Figure 1: Douglas Mine and Pit 23 regional location	7
Figure 2: Pit 23 location	8
Figure 3: Pit 23 updated groundwater monitoring network (as at 31/12/2019).....	12
Figure 4: Groundwater elevation (mAHD) – bores in predicted flow path	14
Figure 5: Groundwater elevation (mAHD) – bores up-gradient of Pit 23.....	14
Figure 6: Groundwater elevation (mAHD) – cross-gradient and background bores.....	15
Figure 7: U-238 and ionic balance trends – up-gradient bores (1 of 2)	31
Figure 8: U-238 and ionic balance trends – up-gradient bores (2 of 2)	31
Figure 9: Ra-228 and ionic balance trends – up-gradient bores (1 of 2)s	31
Figure 10: Ra-228 and ionic balance trends – up-gradient bores (2 of 2)	31
Figure 11: U-238 and ionic balance trends – down-gradient bores (1 of 2)	32
Figure 12: U-238 and ionic balance trends – down-gradient bores (2 of 2)	32
Figure 13: Ra-228 and ionic balance trends – down-gradient bores (1 of 2)	32
Figure 14: Ra-228 and ionic balance trends – down-gradient bores (2 of 2)	32
Figure 15: U-238 and ionic balance trends – cross-gradient bores (1 of 2)	33
Figure 16: U-238 and ionic balance trends – cross-gradient bores (2 of 2)	33
Figure 17: Ra-228 and ionic balance trends – cross-gradient bores (1 of 2)	33
Figure 18: Ra-228 and ionic balance trends – cross-gradient bores (2 of 2)	33
Figure 19: U-238 and ionic balance trends – bores representing background (1 of 2)	34
Figure 20: U-238 and ionic balance trends – bores representing background (2 of 2)	34
Figure 21: Ra-228 and ionic balance trends – bores representing background (1 of 2)	34
Figure 22: Ra-228 and ionic balance trends – bores representing background (2 of 2)	34
Figure 23: GW04 - Selenium as compared against ionic balance trends.....	36
Figure 24: Ra-226 and Ra-228 in surface water.....	40

Figure 25: Uranium and U-238 in surface water	41
Figure 26: PM ₁₀ dust concentrations at neighbouring residences vs. daily rainfall	42
Figure 27: Pit 23 air quality (PM ₁₀) monitoring locations.....	44
Figure 28: Radon and thoron detectors	45
Figure 29: Radon concentration in air, H2 2020	47
Figure 30: Thoron concentration in air, H2 2020	47
Figure 31: Gross Alpha Radiation in PM10 Dust – H2 2020	48
Figure 32: 2019 vs 2020 interpreted groundwater contours (EMM 2019; EMM 2020).....	50

1 Executive Summary

Iluka Resources Limited (Iluka) operates the Pit 23 by-products disposal facility located at the Douglas Mine in the Kanagulk area and within the municipality of the Horsham Rural City.

Pursuant to Planning Permit 15-105 issued by Horsham Rural City Council (HRCC), and the subsidiary Pit 23 Incoming Waste Monitoring Plan (IWMP), the Pit 23 facility is approved for the disposal of mineral separation by-products and used dust filter bags from the Iluka Hamilton Mineral Separation (MSP) which contain or are contaminated with Naturally Occurring Radioactive Material (NORM), and concrete and steel which contains or is contaminated with NORM associated with plant and infrastructure from nominated Iluka sites within Victoria.

Complementing the IWMP are the endorsed Pit 23 Environmental Management Plan (EMP) which addresses the identification, management and monitoring of environmental risks associated with the approved development and use; and the endorsed Rehabilitation and Vegetation Management Plan (R&VMP) which addresses the future rehabilitation of the Pit 23 facility including infrastructure decommissioning, landform reinstatement and end land use.

This report is submitted in accordance with Section 12.2 of the endorsed Iluka Pit 23 EMP and outlines the results of monitoring and management actions undertaken during the period 1st July 2020 to 31st December 2020.

Key commentary on environmental monitoring outcomes and performance against compliance objectives in the Pit EMP for the H2 2020 reporting period:

- There were no exceedances of applicable limits for radionuclides or any other analytes in groundwater in bores down-gradient of Pit 23 attributable to disposal activities;
- There were no surface water discharges from the Pit 23 disturbance area;
- There were no exceedances of applicable limits for radionuclides or any other analytes in groundwater-fed surface water sites down-gradient of Pit 23 attributable to disposal activities;
- No noise complaints were received;
- There were no exceedances of the PM₁₀ limit attributable to Pit 23 operations;
- There were no exceedances of the air concentration limits for radon or thoron;
- Measured concentrations of gross alpha radiation in airborne dust were within the range of historical values; and
- Updated groundwater level contours and flow-paths show no material change from the hydrogeological model contours developed in 2015 by CDM Smith.

Detailed assessment of compliance, key results and management actions are provided in Section 4 and 5 of the enclosed report.

2 Introduction

Iluka Resources Limited (Iluka) operates the Pit 23 by-products disposal facility located at the Douglas Mine in the Kanagulk area and within the municipality of the Horsham Rural City (Figure 1 and Figure 2).

Pursuant to Planning Permit 15-105 issued by Horsham Rural City Council (HRCC), and the subsidiary Pit 23 Incoming Waste Monitoring Plan (IWMP), the Pit 23 facility is approved for the disposal of mineral separation by-products and used dust filter bags from the Iluka Hamilton Mineral Separation (MSP) which contain or are contaminated with Naturally Occurring Radioactive Material (NORM), and concrete and steel which contains or is contaminated with NORM associated with plant and infrastructure from nominated Iluka sites within Victoria.

2.1 Planning Permit 15-105

Under the Horsham Planning Scheme the subject land is in the Farming Zone and under the provisions of that zone a permit is required for use and development for Industry (Refuse Disposal). On 25th February 2017 Planning Permit 15-105, (the Permit) was issued by the Horsham Rural City Council as the Responsible Authority to allow:

Use and development of the land for the disposal of waste by-products associated with or sourced through mineral sands processing undertaken at the Hamilton Mineral Separation Plant (MSP), including waste by-products and contaminated materials resulting from the processing and transport operations as follows:

- *By-products from the processing of heavy mineral concentrate at the Hamilton MSP;*
- *used dust filter bags from the Hamilton MSP; and*
- *Other chemically inert material contaminated with naturally occurring radioactive material.*

in accordance with the endorsed plans.

2.2 Commencement of the Permit

Condition 1 of the Permit states:

This permit does not come into operation until:

- a. *Iluka has applied to the Department of Economic Development, Jobs, Transport and Resources to vary the 2003 Work Plan to identify a new endues utilisation of Pit 23 and to vary the rehabilitation plan; and*
- b. *Iluka has applied to the Minister to surrender part of MIN 5367 (Pit 23); and*
- c. *The Department of Economic Development, Jobs, Transport and Resources has approved the Work Plan Variation; and*
- d. *The Minister has registered the partial surrender of MIN 5367.*

The permit comes into operation on the same day the Work Plan Variation is approved, and the partial surrender of MIN 5367 is registered.

The Variation to the 2003 Douglas Mine Work Plan was approved on the 13th April 2017, and the partial surrender of MIN5367 was registered on 11th May 2017, this being the date of commencement of the Permit.

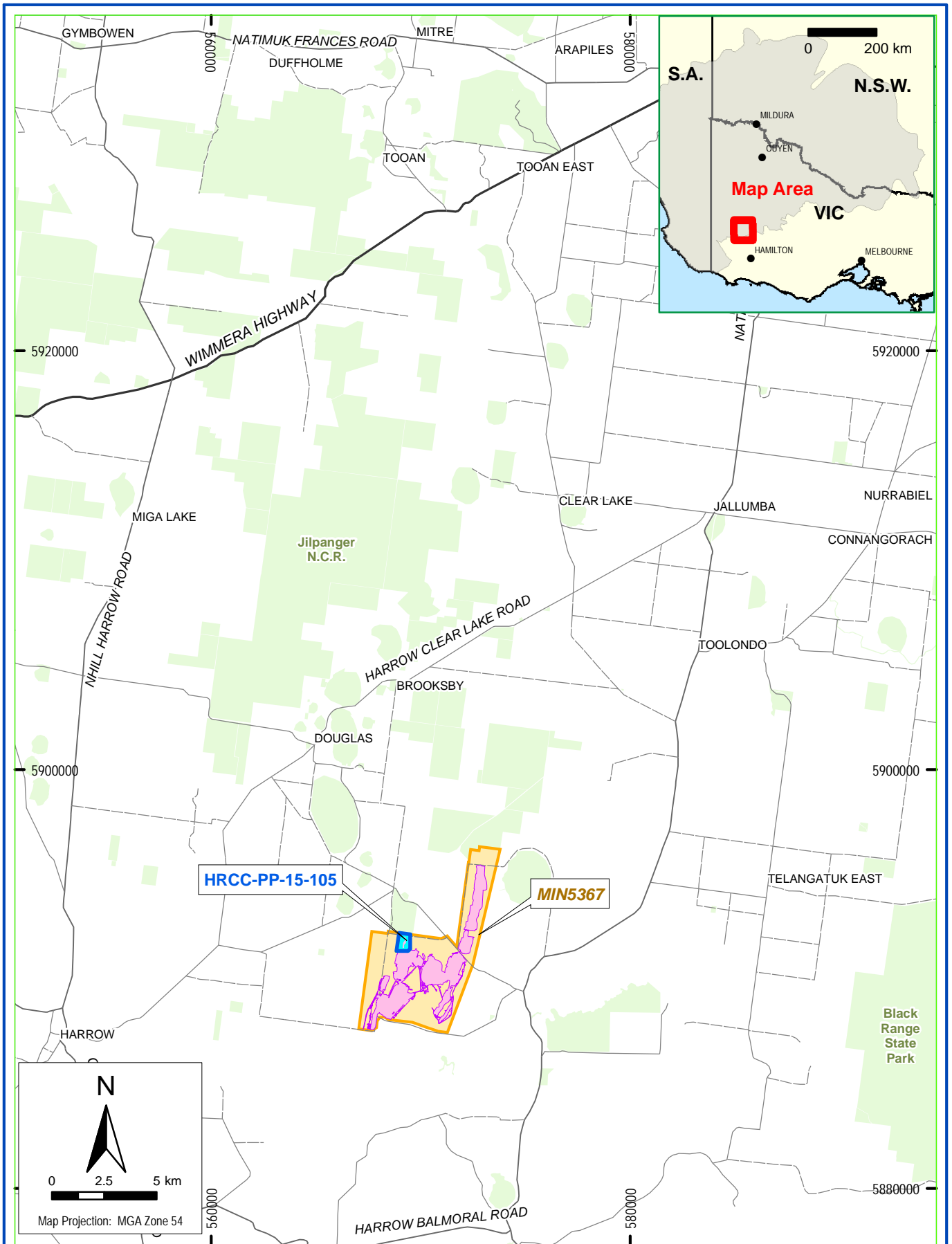

Legend

- Douglas mine
- Pit 23
- HRCC-PP-15-105
- MIN5367 tenement

DOUGLAS

LOCATION PLAN



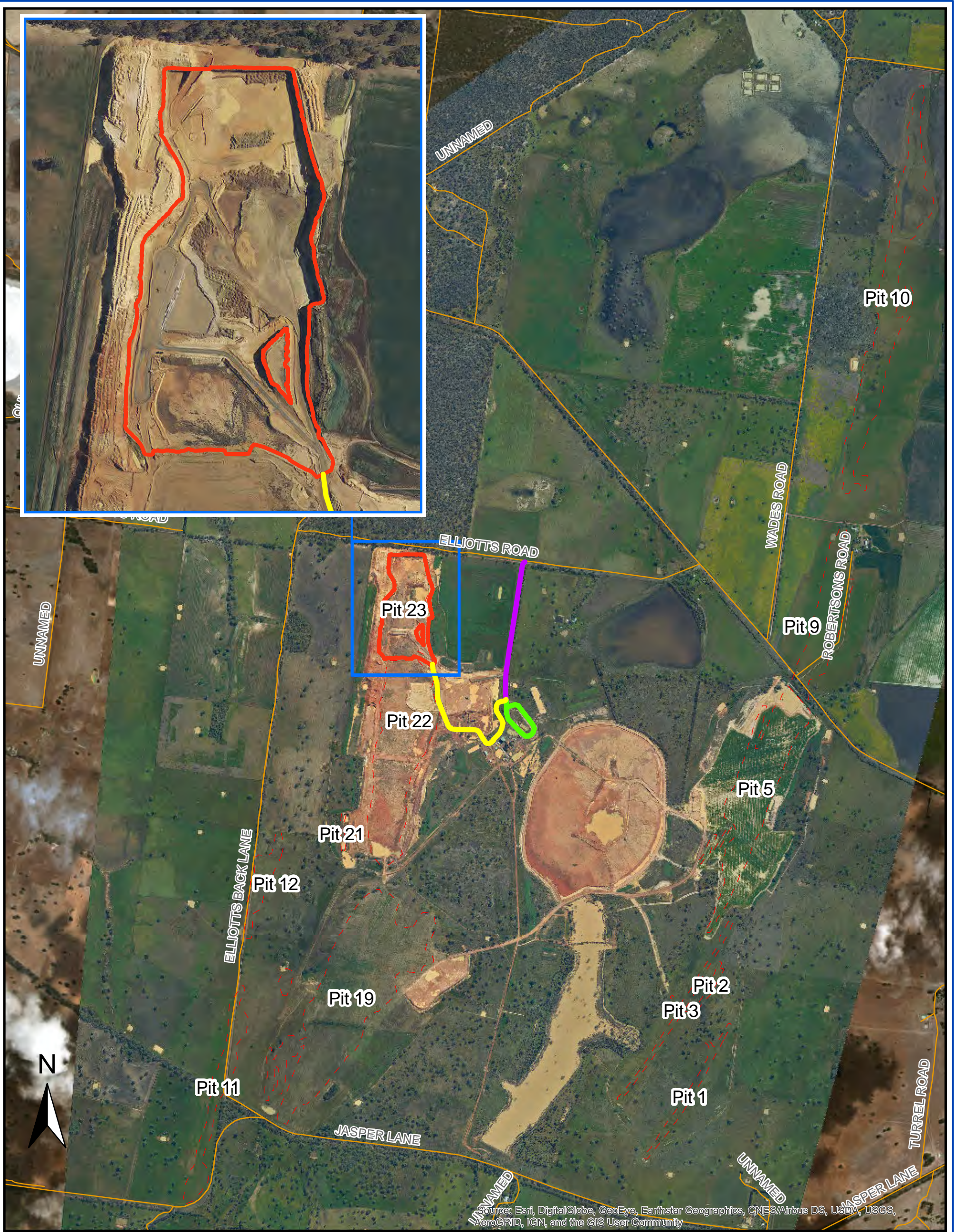

Source: Esri, DigitalGlobe, GeoEye, Earthstar Geographics, CNES/Airbus DS, USDA, USGS, AeroGRID, IGN, and the GIS User Community

Legend

- Pit 23 haul road
- Mine Access Road
- Truck wash circuit
- Pit 23 crest
- Pit Crests
- Roads

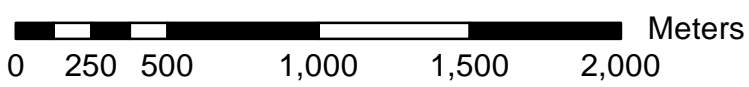

LOCATION OF PIT 23



2.3 Endorsed Plans

Conditions 2, 3, 9, 14, 16 and 34 of the Permit relate to various management plans that once approved by the Responsible Authority will be endorsed to form part of the Permit, which includes:

- Incoming Waste Monitoring Plan (IWMP);
- Environmental Management Plan (EMP), incorporating;
 - Groundwater Monitoring and Management Plan (GWMMP);
 - Surface Water Monitoring and Management Plan (SWMMP);
 - Air Quality/Dust Control Plan (AQMP); and
- Rehabilitation and Vegetation Management Plan (R&VMP)

The plans were endorsed by Horsham Rural City Council on 17th July 2017.

2.4 Performance reporting

Section 12.2 of the endorsed EMP (Rev 4, July 2017) outlines the routine reporting requirements for the mineral sands by-product disposal operations which are:

A review of the performance will be completed and an EMP and Rehabilitation Performance report prepared annually, or less frequently as may be agreed with the Responsible Authority.

Each EMP and Rehabilitation Performance Report will include, at least:

- *for the period from the previous EMP and Rehabilitation Performance Report:*
 - *the total tonnage of materials disposed of;*
 - *the average and maximum number of deliveries of materials disposed of per day; and*
 - *the results of all measurements of:*
 - *noise levels made in response to a complaint regarding noise;*
 - *PM10 concentrations in air at sensitive receptors;*
 - *environmental radiation monitoring results in accordance with the approved Radiation Management Plan, which will generally include:*
 - *radon concentration in air;*
 - *gross alpha activity concentration of airborne dust; and*
 - *radionuclide concentrations in groundwater and surface water;*
 - *discussion of any implications of the results of groundwater level monitoring on groundwater flow paths from Pit 23; and*
 - *descriptions of any model review and recalibration completed and the results of subsequent model re-runs;*
- *the maximum elevation of the upper surface of materials disposed of at the end of the reporting period;*
- *a detailed discussion of all non-compliant events including progress toward resolution;*
- *a summary of comments and complaints received and resulting actions;*
- *plans for the next year; and*
- *discussion on other matters considered relevant by the Responsible Authority or Iluka.*

Deficiencies identified in an EMP and Rehabilitation Performance Report that can be addressed without amendment of this plan will be addressed as soon as practicable.

Per Section 13.2 of the EMP, the EMP and Rehabilitation Performance Reports will be subject to review by an independent auditor prior to submission to the Responsible Authority.

2.5 Rehabilitation and Vegetation Management Plan

Due to continued operations within Pit 23 no actions relevant to rehabilitation and vegetation management were undertaken in the H2 2020 reporting period.

3 Delivery and Disposal of Materials into Pit 23

No wastes were disposed into Pit 23 during the H2 2020 reporting period.

4 Monitoring Results

4.1 Groundwater

4.1.1 Bore network status

The Pit 23 bore network includes additional monitoring bores installed in 2018 per the recommendations in the independent desktop review of proposed by-product disposal (EES, 2016). Since the installation of these bores, the augmented bore network satisfies Condition 28(c) of the Permit. The status of Pit 23 monitoring bore network is given in Table 1.

As per the auditors recommendations (Golders 2020) from the H1 2020 Performance Report a new monitoring bore (GW04A) was installed in October 2020:

- consistent with Section 7.6.3 the bore (GW04A) was installed by a licensed driller pursuant to a 'Licence to Construct Works' (Works Licence WLE079378) issued by GWM Water; and
- as per Condition 28(d) of the Permit, the bore installation was supervised by qualified hydrogeologist.

Permeability assessment of the newly installed bore GW04A was completed in the reporting period with a permeability result of 0.97m/day which is consistent with values used in previous modelling predictions conducted by CDM Smith (2014) and EMM (2019) that utilised a horizontal hydraulic conductivity range of 0.1 to 15m/day thereby no update or review of the groundwater model is required.

Monitoring bore locations are provided in Figure 3.

Table 1: Pit 23 bore status (as at 31/12/2020)

Well ID	Comment	Status / Condition
BORES UP-GRADIENT OF PIT 23		
WRK301		OK
WRK302		OK
WRK303		OK
WRK304		OK
GW08	Installed 18/10/18	OK
GW06	Installed 23/5/18	OK
GW05	Installed 17/10/18	OK
BORES DOWN-GRADIENT OF PIT 23 (IN PREDICTED FLOW PATH)		
BW36A	Installed 15/10/19	To replace BW36
WRK300		OK

Well ID	Comment	Status / Condition
GW01	Installed 23/5/18	OK
GW02	Installed 17/10/18	OK
GW03	Installed 17/10/18	OK
GW04A	Installed 15/10/2020	OK
BW5	In predicted flow path	OK
BORES CROSS-GRADIENT TO PIT 23 FLOW PATH		
GW04*	Installed 18/10/18	OK
GW07	Installed 23/5/18	OK
BW28A *		OK
BW45B	Installed 18/10/18 – replaced BW45	OK
BORES REPRESENTATIVE OF BACKGROUND		
IWB2	Representative of background	OK
IWB6	Representative of background	OK
BW53 (“Puls”)	Representative of background	OK
* BW28A and GW04 are incorrectly referenced in the current endorsed EMP (Rev 4, July 2017) as being down-gradient of Pit 23. Groundwater modelling per CDM Smith (2014) and EMM (2019) indicate that BW28A and GW04 are cross-gradient to the predicted flow path from Pit 23.		

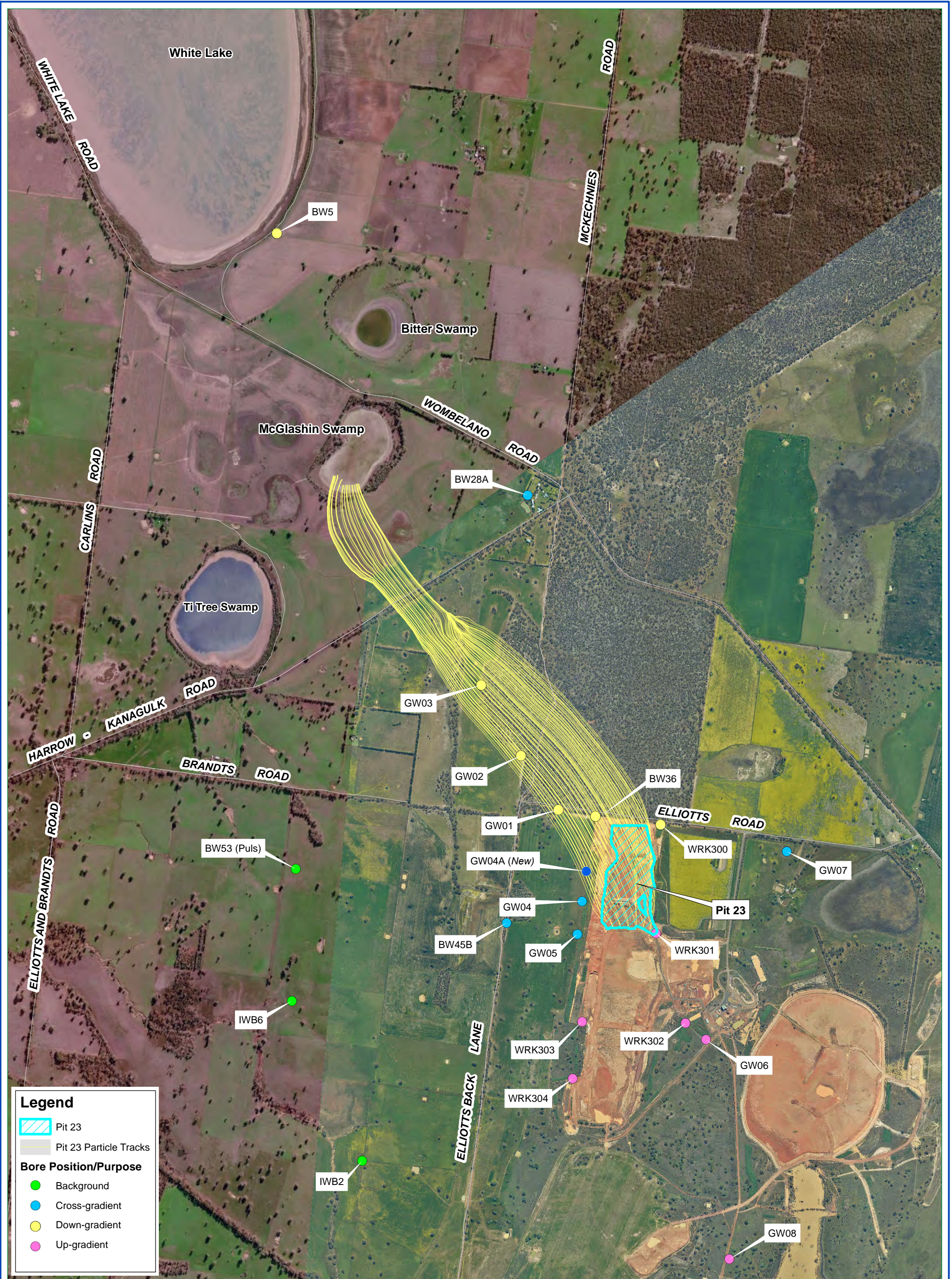

Site photo: 5 Oct. 2018

DOUGLAS MINE PIT 23 MONITORING BORE NETWORK & GROUNDWATER FLOW PATH



4.1.2 Standing water levels

In accordance with Section 7.9.1 of the current endorsed EMP (Rev 4, July 2017) groundwater levels are measured on a monthly basis at bores WRK300 – WRK304 inclusive, GW01 to GW08 inclusive and BW36A and BW45B. All other bores (BW5, BW28A, BW53, IWB2 and IWB6) are measured on a biannual basis.

Groundwater level hydrographs for these bores expressed in groundwater elevation (metres above Australian Height Datum, mAHD) are given in Table 2 and Figure 4 – Figure 6. Data includes that obtained during scheduled events and ad-hoc measurements.

All bores along the predicted flow path (Figure 4) exhibit stable standing water levels in the preceding 24-month period and in comparison to long-term trends; bores up-gradient of Pit 23 (Figure 5) exhibit relatively stable water levels with minor fluctuation.

Table 2: Monitoring bores - standing water Levels (mAHD)

Bore ID	Jul-20	Aug-20	Sep-20	Oct-20	Nov-20	Dec-20
BORES UP-GRADIENT OF PIT 23						
GW05	178.9	178.9	178.9	178.9	179.0	179.0
GW06	176.2	176.2	176.1	176.2	176.2	176.2
GW08	177.5	177.6	177.4	177.6	177.5	177.5
WRK301	178.2	178.2	178.2	178.2	178.2	178.2
WRK302	176.8	176.7	176.8	176.7	176.8	176.8
WRK303	179.8	179.9	179.9	179.9	179.9	179.9
WRK304	180.4	180.5	180.5	180.4	180.4	180.4
BORES DOWN-GRADIENT OF PIT 23 (IN PREDICTED FLOW PLATH)						
BW05	147.4	*	*	*	*	*
WRK300	175.1	175.1	175.1	175.2	175.2	175.2
BW36A	174.5	174.4	174.6	174.4	174.5	174.5
GW01	173.5	173.5	173.4	173.4	173.4	173.5
GW02	170.8	170.8	170.7	170.9	170.8	170.8
GW03	162.0	162.1	162.0	162.1	162.0	162.0
GW04A	<i>GW04A newly installed Nov 2020</i>				177.0	177.0
BORES CROSS GRADIENT TO PIT 23 FLOW PATH						
BW28A	152.5	152.5	*	*	*	*
BW45B	177.4	177.4	177.4	177.3	177.4	177.4
GW04	178.1	178.2	178.1	178.2	178.3	178.3
GW07	172.5	172.5	172.5	172.5	172.5	172.5
BORES REPRESENTATIVE OF BACKGROUND						
IWB2	179.7	179.9	179.7	179.7	179.8	179.7
IWB6	176.9	177.0	176.7	176.8	176.4	176.5
BW53 ("Puls")	175.8	176.3	176.2	176.3	176.2	176.3
<u>Notes</u>						
<ul style="list-style-type: none"> bores are listed according to their position relative to the Pit 23 groundwater flow path bores down-gradient (on predicted flow path) are listed in order of their position along the path of flow dates marked with an asterisk (*) indicates no scheduled sampling required 						

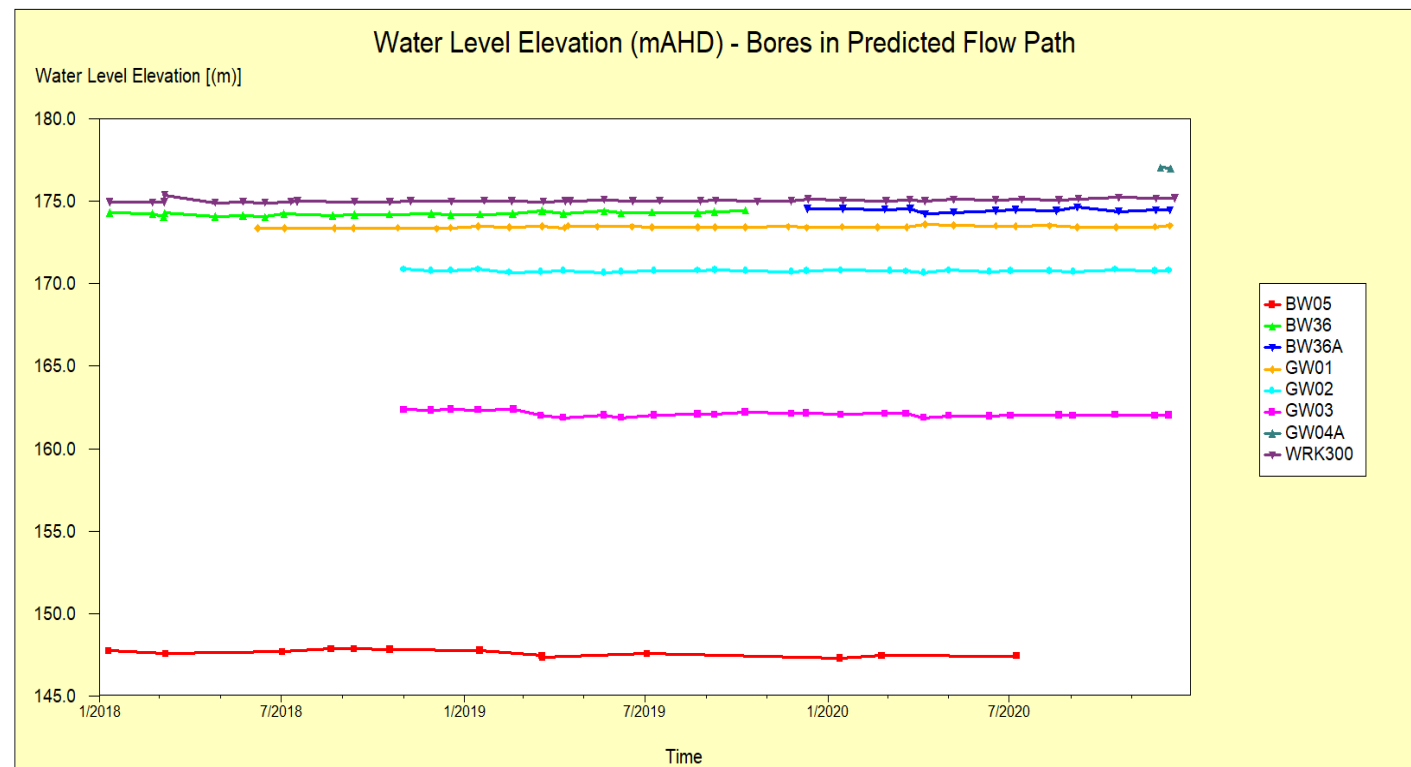
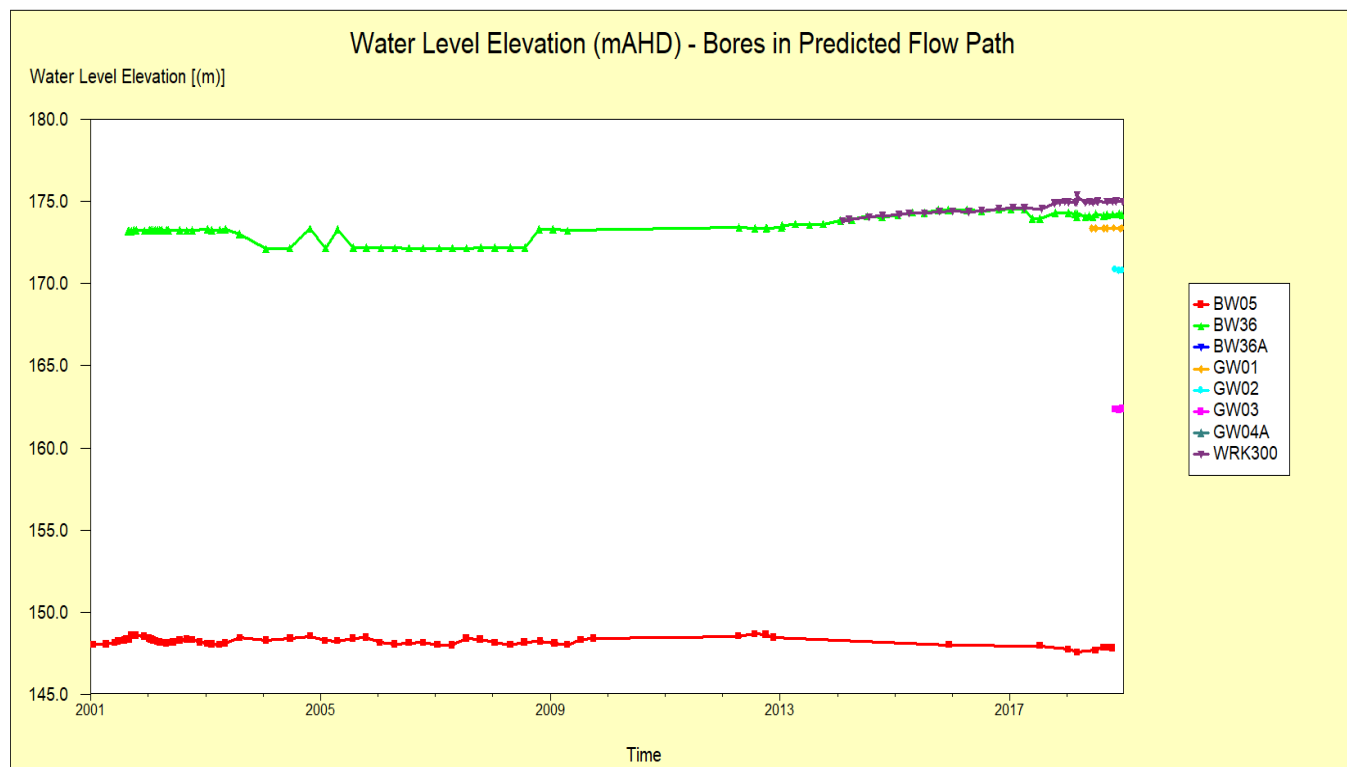

Figure 4: Groundwater elevation (mAHD) – bores in predicted flow path

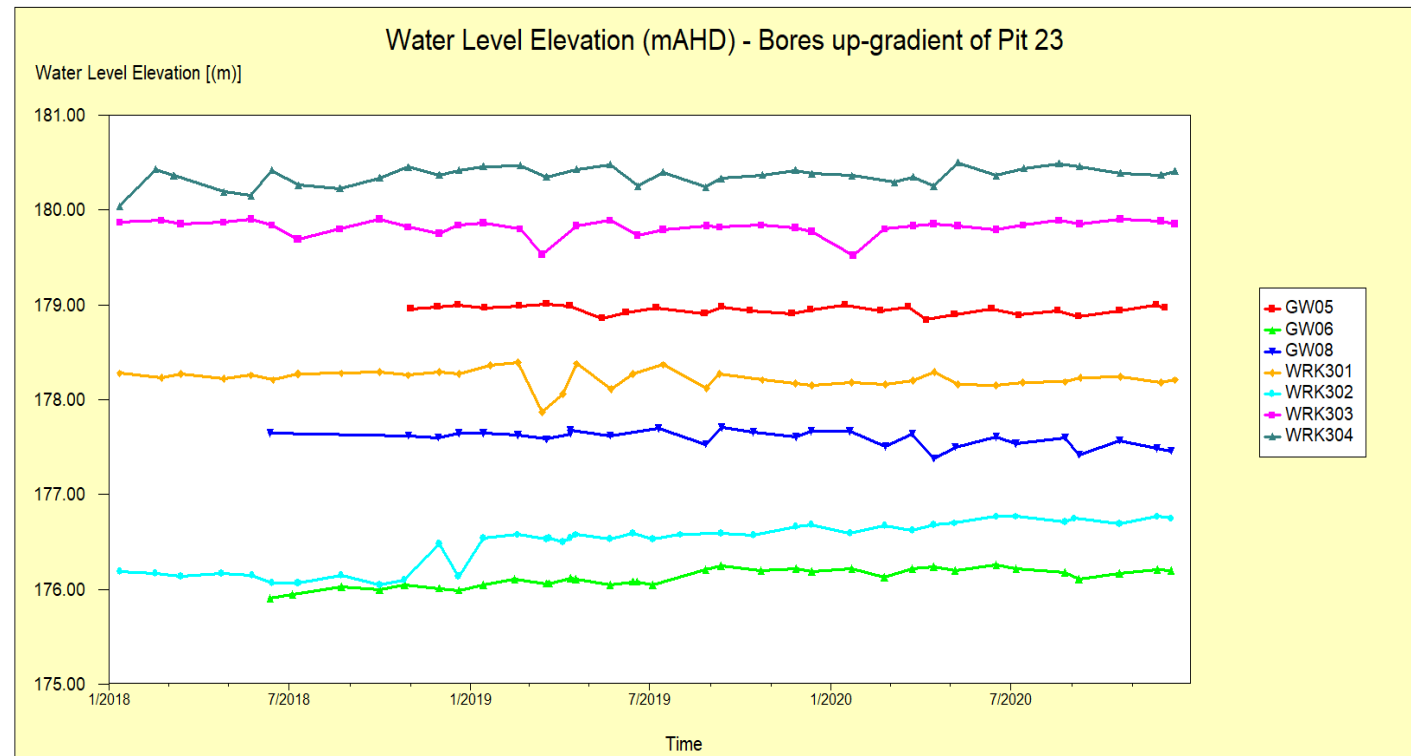
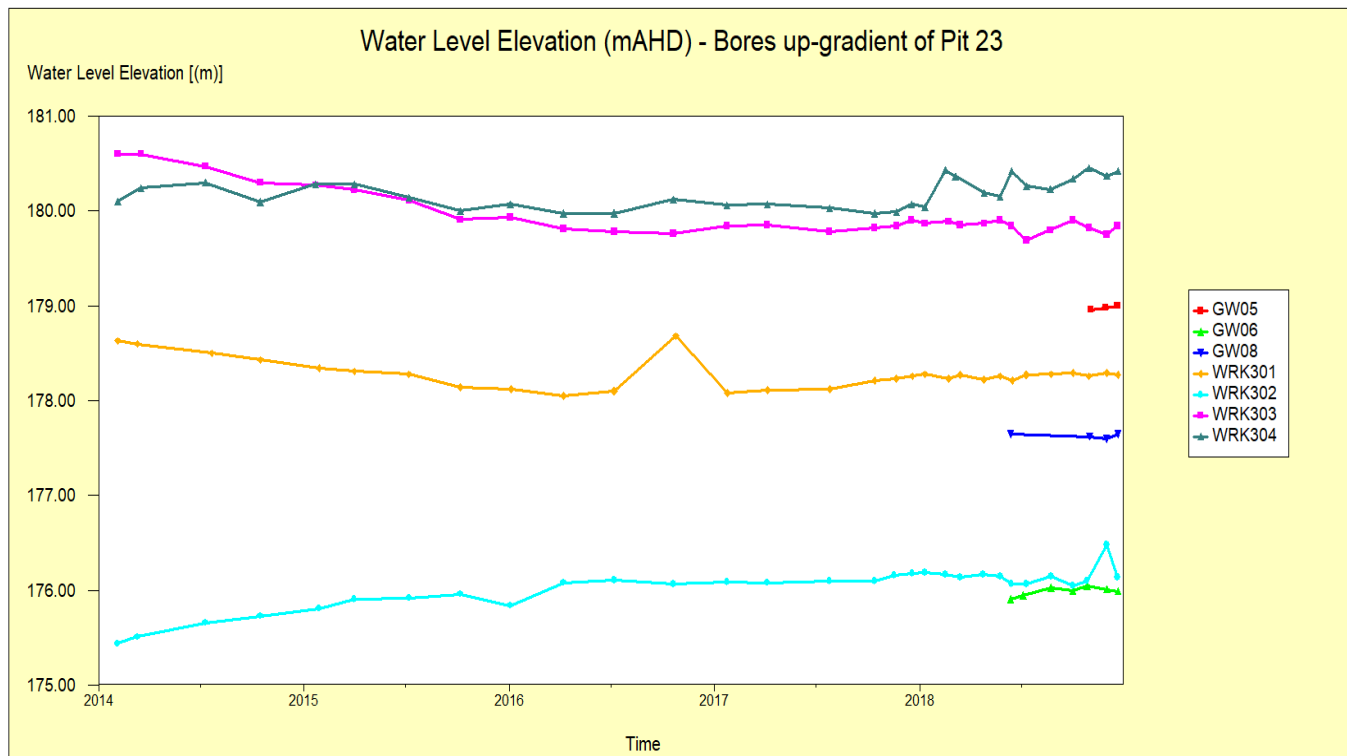

Figure 5: Groundwater elevation (mAHD) – bores up-gradient of Pit 23

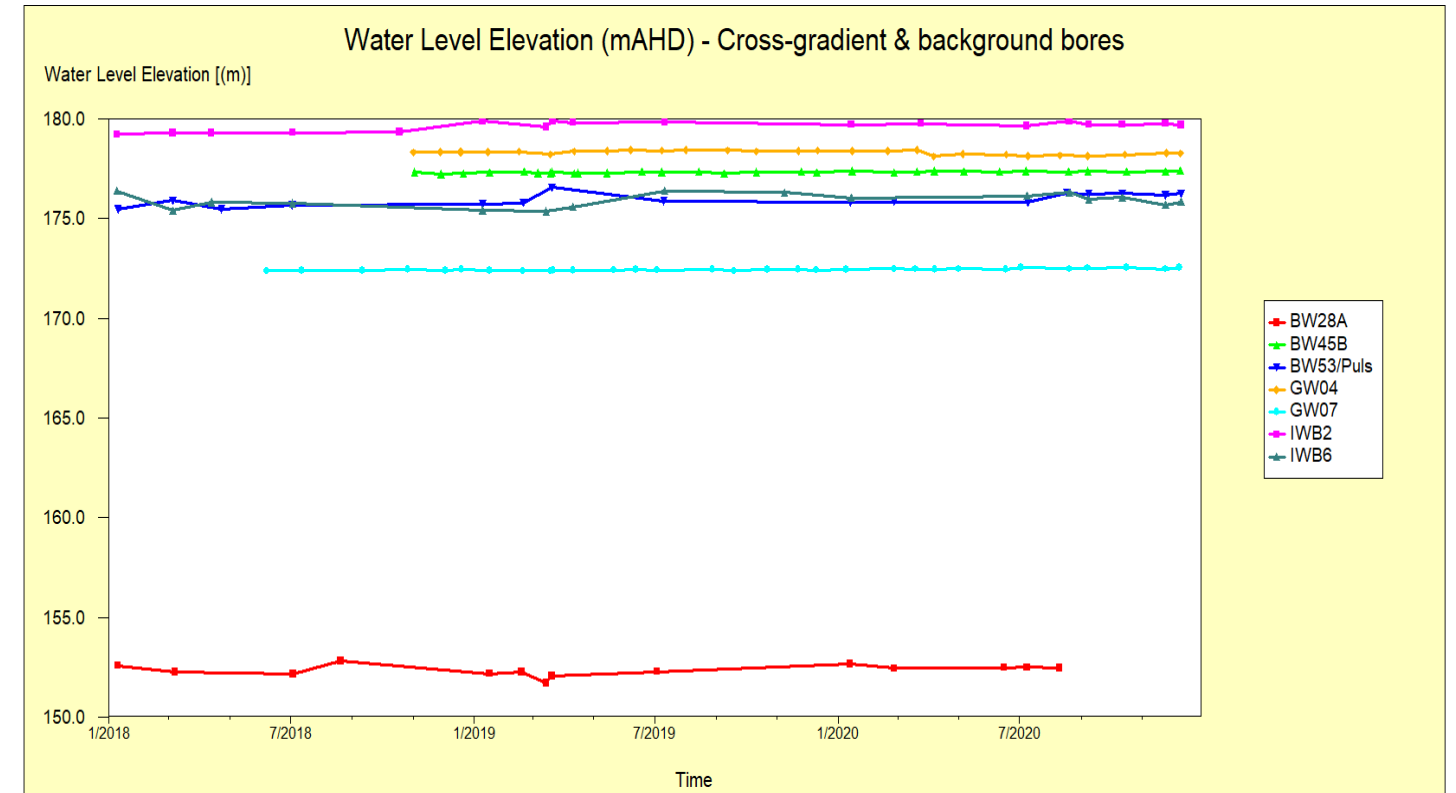
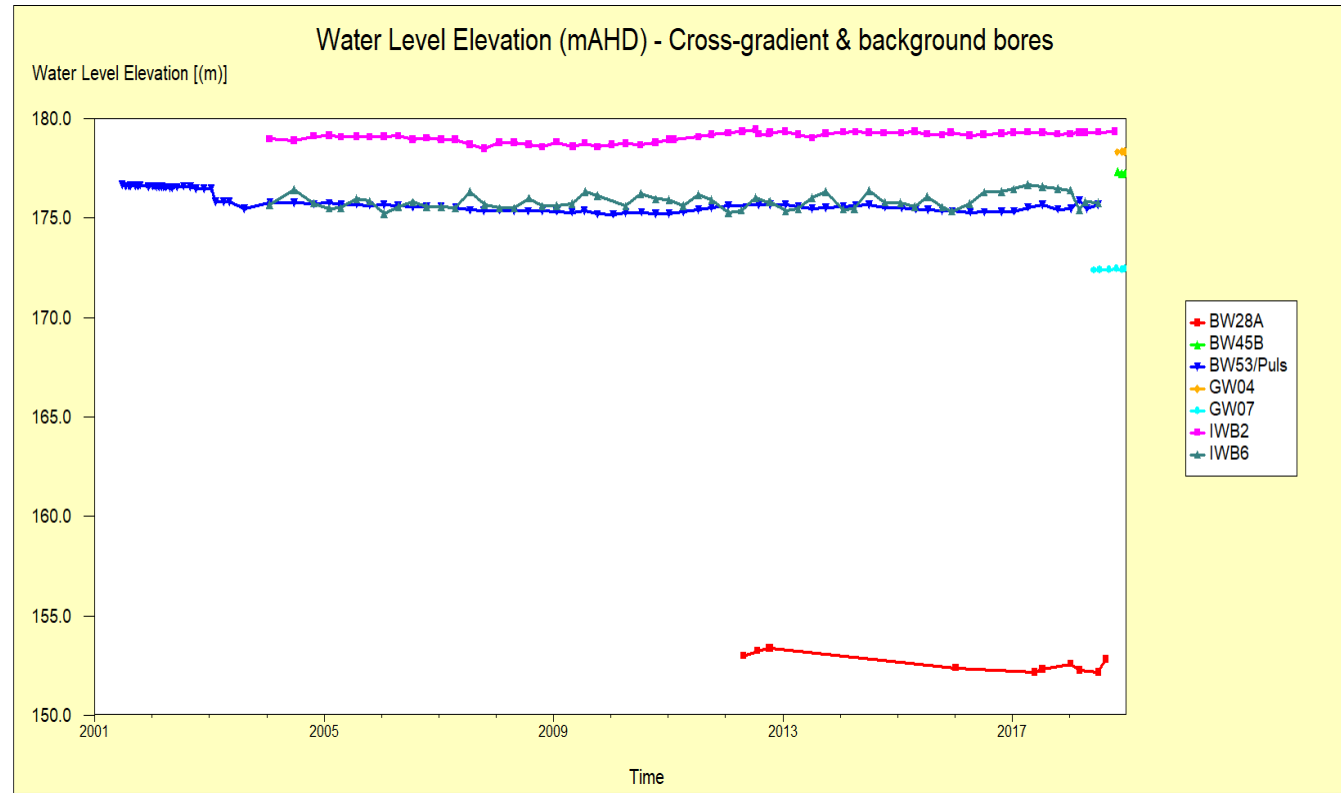

Figure 6: Groundwater elevation (mAHD) – cross-gradient and background bores

4.1.3 Groundwater quality

4.1.3.1 Ionic balance ratios

Per Section 7.9.2 of the current endorsed EMP (Revision 4, July 2017) chloride:sulfate (CL:SO₄) and sodium:calcium (Na:Ca) ratios in groundwater are assessed from results obtained during scheduled and/or follow-up groundwater sampling events. Per the EMP, a consecutive reduction in either ratio of >10% applies as a potential indicator of seepage from Pit 23 having arrived in a bore and is a trigger for further investigation. Per the EMP, further investigation would include:

- comparing the timing of the consecutive >10% reduction in ionic ratios with the hydrogeological model predictions;
- comparing the timing of the ionic balance trigger with other analytes (e.g. radionuclides, heavy metals) to identify any corresponding exceedances in those analytes in the same rounds of sampling;
- where such a correlation exists completing a detailed investigation of cause and impact, including possible reviews of hydrogeological or solute transport models.

Calculated Cl:SO₄ and Na:Ca for the reporting period are given in Table 3. As above, this includes ratios as determined from the results of scheduled and follow-up sampling.

Reductions of >10% in either of the ionic ratios in consecutive and/or follow-up sampling events occurred at three bores (WRK304, BW36A and GW04) during the reporting period one of which (BW36A) is located down-gradient to Pit 23 however there were no corresponding exceedances for other analytes in bore BW36A or WRK304.

As detailed further in Section 4.1.3.3, the ionic balance trigger for GW04 corresponded with elevated Selenium results, however, these results are below the upper trigger limit based on background values which have naturally elevated concentrations at GW04 and are above the standard SEPP WoV objectives. These observations are not considered to be associated with Pit 23.

Table 3: Groundwater monitoring locations – ionic ratio balance results

Bore ID	Date	Cl (mg/L)	SO ₄ (mg/L)	CL:SO ₄ (Ratio)	% Red.	Na (mg/L)	Ca (mg/L)	Na:Ca (Ratio)	% Red.	Repeated ratio exceedance?
BORES UP-GRADIENT OF PIT 23										
GW05	28/11/2018	3100	560	5.5	<i>I.D.</i>	1800	170	10.6	<i>I.D.</i>	
	15/01/2019	3800	790	4.8	13%	2200	200	11	-4%	
	19/02/2019	3700	740	5	10%	2000	180	11.1	-5%	
	8/07/2019	3100	660	4.7	2%	1900	140	13.6	-23%	
	15/01/2020	2600	640	4	14%	1700	81	20.9	-55%	
	20/02/2020	2800	620	4.5	4%	1900	87	21.8	-61%	
	9/07/2020	2700	640	4.2	-4%	1900	84	22.6	-8%	
17/08/2020	2600	590	4.4	-8%	1700	95	17.9	15%		
GW06	12/06/2018	6600	1500	4.4	<i>I.D.</i>	3400	660	5.2	<i>I.D.</i>	
	14/01/2019	6700	1700	3.9	10%	3400	630	5.4	-5%	
	21/03/2019	6800	1600	4.3	-8%	3400	620	5.5	-2%	
	17/04/2019	7000	1500	4.7	-10%	3500	640	5.5	0%	
	22/05/2019	6800	1400	4.9	-4%	3400	670	5.1	7%	
	18/06/2019	6800	1500	4.5	7%	3400	580	5.9	-16%	

Bore ID	Date	Cl (mg/L)	SO4 (mg/L)	CL:SO4 (Ratio)	% Red.	Na (mg/L)	Ca (mg/L)	Na:Ca (Ratio)	% Red.	Repeated ratio exceedance?
	4/07/2019	6800	1500	4.5	0%	3500	610	5.7	2%	
	22/01/2020	6000	1600	3.8	17%	3400	610	5.6	3%	
	24/02/2020	6700	1500	4.5	1%	3400	600	5.7	1%	
	6/07/2020	6400	1500	4.3	-14%	3500	590	5.9	-6%	
GW08	29/11/2018	5300	1100	4.8	I.D.	2800	390	7.2	I.D.	
	14/01/2019	6600	1300	5.1	-5%	3200	540	5.9	17%	
	18/02/2019	6700	1400	4.8	1%	3300	540	6.1	15%	Yes (Na:Ca)
	10/07/2019	6700	1200	5.6	-10%	3600	550	6.5	-10%	
	20/01/2020	6500	1300	5	10%	3400	520	6.5	0%	
	25/02/2020	6700	1300	5.2	8%	3600	540	6.7	-2%	
	5/05/2020	6800	1300	5.2	6%	3800	400	9.5	-45%	
	6/07/2020	6600	1300	5.1	-2%	3400	530	6.4	2%	
WRK301	26/07/2017	3100	640	4.8	I.D.	1600	240	6.7	I.D.	
	11/01/2018	3100	650	4.8	2%	1700	250	6.8	-2%	
	10/07/2018	3100	480	6.5	-35%	1700	260	6.5	4%	
	21/01/2019	3400	670	5.1	21%	1700	290	5.9	10%	
	18/02/2019	3400	690	4.9	24%	1700	260	6.5	-12%	Yes (CL:SO4)
	15/07/2019	3200	570	5.6	-11%	1700	230	7.4	-26%	
	22/01/2020	3100	600	5.2	8%	1700	260	6.5	12%	
	25/02/2020	3200	600	5.3	5%	1800	270	6.7	10%	
	13/07/2020	3200	600	5.3	-3%	1800	260	6.9	-6%	
WRK302	10/07/2018	6500	1300	5	-15%	3500	520	6.7	8%	
	14/01/2019	6500	1500	4.3	13%	3500	490	7.1	-6%	
	18/02/2019	6700	1400	4.8	4%	3300	540	6.1	9%	
	21/03/2019	6600	1500	4.4	12%	3500	490	7.1	-6%	
	17/04/2019	6600	1300	5.1	-2%	3400	530	6.4	5%	
	22/05/2019	6700	1300	5.2	-3%	3500	510	6.9	-2%	
	4/07/2019	6400	1400	4.6	-5%	3600	460	7.8	-10%	
	1/08/2019	6500	1400	4.6	-7%	3400	480	7.1	1%	
	20/01/2020	6200	1500	4.1	10%	3500	460	7.6	3%	
	6/07/2020	6200	1400	4.4	-7%	3400	520	6.5	14%	
3/09/2020	6300	1400	4.5	-9%	3300	430	7.7	-1%		
WRK303	25/07/2017	2100	570	3.7	I.D.	1200	93	12.9	I.D.	
	11/01/2018	2100	550	3.8	-4%	1300	97	13.4	-4%	
	10/07/2018	2400	570	4.2	-10%	1400	110	12.7	5%	
	14/01/2019	2500	620	4	4%	1500	130	11.5	9%	
	15/07/2019	2700	570	4.7	-17%	1600	120	13.3	-16%	
	23/01/2020	2700	560	4.8	-2%	1800	140	12.9	4%	
	13/07/2020	2800	580	4.8	0%	1700	150	11.3	12%	

Bore ID	Date	Cl (mg/L)	SO4 (mg/L)	CL:SO4 (Ratio)	% Red.	Na (mg/L)	Ca (mg/L)	Na:Ca (Ratio)	% Red.	Repeated ratio exceedance?	
	19/08/2020	2900	590	4.9	-2%	1600	120	13.3	-4%		
WRK304	10/07/2018	2200	640	3.4	0%	1400	93	15.1	-3%		
	14/01/2019	2200	680	3.2	6%	1400	87	16.1	-7%		
	15/07/2019	2400	640	3.8	-16%	1500	94	16	1%		
	22/01/2020	2500	700	3.6	5%	1700	100	17	-7%		
	5/03/2020	2500	640	3.9	-4%	1600	110	14.5	9%		
	14/07/2020	2400	650	3.7	-3%	1600	110	14.5	14%		
	19/08/2020	2500	640	3.9	-9%	1400	110	12.7	25%	Yes (Na:Ca)	
BORES DOWN-GRADIENT OF PIT 23											
BW05	18/10/2018	8800	800	11	23%	4900	260	18.8	-11%		
	17/01/2019	8300	960	8.6	17%	4500	290	15.5	35%		
	20/03/2019	8400	890	9.4	10%	4700	260	18.1	24%	Yes (Na:Ca)	
	3/07/2019	8300	860	9.7	-12%	4600	240	19.2	-24%		
	13/01/2020	7800	870	9	7%	4700	240	19.6	-2%		
	8/07/2020	7900	880	9	0%	4700	260	18.1	8%		
BW36A	12/07/2017	2200	420	5.2	I.D.	1300	74	17.6	I.D.		
	10/01/2018	2000	360	5.6	-6%	1200	82	14.6	17%		
	6/03/2018	1900	360	5.3	5%	1100	61	18	-3%		
	<i>Bore blocked - replaced with BW36A in Oct 2019</i>										
	11/12/2019	1200	160	7.5	I.D.	760	76	10	I.D.		
	16/01/2020	1200	90	13.33	-78%	770	69	11.2	-12%		
	7/07/2020	1900	240	7.9	41%	1200	120	10	10%		
	17/08/2020	2100	220	9.5	28%	1300	110	11.8	-6%	Yes (Cl:SO4)	
GW01	7/06/2018	930	110	8.5	I.D.	490	82	6	I.D.		
	15/01/2019	3400	400	8.5	-1%	1800	65	27.7	-363%		
	20/03/2019	3500	420	8.3	2%	2000	68	29.4	-6%		
	15/04/2019	3700	370	10	-18%	1900	75	25.3	9%		
	14/05/2019	3400	360	9.4	-11%	2100	64	32.8	-18%		
	18/06/2019	3400	420	8.1	5%	1800	56	32.1	-16%		
	8/07/2019	3400	400	8.5	0%	1900	58	32.8	-18%		
	15/01/2020	3500	470	7.4	12%	1900	92	20.7	37%		
	20/02/2020	3400	450	7.6	11%	1900	73	26	21%	Yes (Both)	
	7/07/2020	3300	550	6.6	11%	2000	82	24.4	-18%		
GW02	10/08/2020	3400	440	7.7	-4%	1800	78	23.1	-12%		
	28/11/2018	2100	410	5.1	I.D.	1300	38	34.2	I.D.		
	15/01/2019	2000	330	6.1	-18%	1200	26	46.2	-35%		
	10/07/2019	2300	330	7	-15%	1300	21	61.9	-34%		
	14/01/2020	2100	340	6.2	11%	1200	19	63.2	-2%		
3/03/2020	2000	290	6.9	1%	1200	17	70.6	-14%			

Bore ID	Date	Cl (mg/L)	SO4 (mg/L)	CL:SO4 (Ratio)	% Red.	Na (mg/L)	Ca (mg/L)	Na:Ca (Ratio)	% Red.	Repeated ratio exceedance?
	2/07/2020	2100	420	5	19%	1200	21	57.1	10%	
	10/08/2020	2100	370	5.7	8%	1200	19	63.2	0%	
GW03	28/11/2018	2900	510	5.7	I.D.	1800	190	9.5	I.D.	
	15/01/2019	3100	590	5.3	8%	1900	270	7	26%	
	19/02/2019	3500	630	5.6	-6%	1800	180	10	-6%	
	10/07/2019	3400	540	6.3	-20%	1900	170	11.2	-59%	
	14/01/2020	3300	550	6	5%	1800	160	11.3	-1%	
	2/07/2020	3300	570	5.8	4%	1900	170	11.2	1%	
	14/01/2021	3300	630	5.2	10%	2000	180	11.1	1%	
GW04A	<i>New bore GW04A installed in Oct 2020</i>									
	30/11/2020	2300	360	6.4	I.D.	1300	120	10.8	I.D.	
WRK300	10/01/2018	1700	320	5.3	6%	1000	150	6.7	13%	
	6/03/2018	1700	330	5.2	3%	920	130	7.1	8%	
	17/07/2018	1600	290	5.5	-7%	880	140	6.3	11%	
	18/10/2018	1700	310	5.5	-3%	910	130	7	-5%	
	21/01/2019	1800	300	6	-9%	910	150	6.1	3%	
	18/02/2019	1700	330	5.2	7%	910	130	7	-11%	
	21/03/2019	1800	310	5.8	-5%	1000	180	5.6	12%	
	17/04/2019	1800	290	6.2	-13%	970	150	6.5	-3%	
	16/07/2019	1700	300	5.7	6%	990	130	7.6	-26%	
	16/01/2020	1700	310	5.5	3%	1100	150	7.3	4%	
13/07/2020	1700	320	5.3	3%	930	140	6.6	9%		
BORES CROSS-GRADIENT OF PIT 23										
BW28A *	20/08/2018	7200	870	8.3	-14%	3600	510	7.1	-7%	
	17/01/2019	7100	1000	7.1	9%	3500	540	6.5	8%	
	18/02/2019	7200	1100	6.5	16%	3400	490	6.9	-7%	
	3/07/2019	7100	920	7.7	-9%	3600	500	7.2	-11%	
	13/01/2020	6900	960	7.2	7%	3400	460	7.4	-3%	
	26/02/2020	7000	850	8.2	-7%	3600	490	7.3	-2%	
	8/07/2020	7100	920	7.7	-7%	3500	500	7	5%	
10/08/2020	7100	870	8.2	-14%	3200	480	6.7	10%		
BW45B	29/11/2018	4800	840	5.7	I.D.	2500	290	8.6	I.D.	
	17/01/2019	5100	960	5.3	7%	2500	320	7.8	9%	
	6/03/2019	5100	910	5.6	2%	2500	310	8.1	6%	
	20/03/2019	5300	960	5.5	3%	2700	320	8.4	2%	
	15/04/2019	5400	810	6.7	-17%	2600	300	8.7	-1%	
	14/05/2019	5100	870	5.9	-3%	2900	320	9.1	-5%	
	18/06/2019	5300	860	6.2	-8%	2700	290	9.3	-8%	
8/07/2019	5000	860	5.8	-9%	2800	310	9	-16%		

Bore ID	Date	Cl (mg/L)	SO4 (mg/L)	CL:SO4 (Ratio)	% Red.	Na (mg/L)	Ca (mg/L)	Na:Ca (Ratio)	% Red.	Repeated ratio exceedance?
	14/08/2019	4900	860	5.7	-7%	2600	320	8.1	-4%	
	15/01/2020	4900	920	5.3	8%	2800	320	8.8	-8%	
	26/02/2020	5100	810	6.3	-8%	2700	300	9	-11%	
	7/07/2020	5200	900	5.8	-8%	2900	330	8.8	0%	
	19/08/2020	5100	810	6.3	-18%	2600	310	8.4	4%	
GW04 *	28/11/2018	2700	690	3.9	<i>I.D.</i>	1700	120	14.2	<i>I.D.</i>	
	15/01/2019	2800	720	3.9	1%	1900	110	17.3	-22%	
	8/07/2019	2800	640	4.4	-13%	1700	120	14.2	18%	
	1/08/2019	3000	570	5.3	-35%	1600	140	11.4	34%	Yes (Na:Ca)
	12/09/2019	2900	680	4.3	-10%	1700	130	13.1	24%	Yes (Na:Ca)
	15/01/2020	2900	520	5.6	-27%	1600	140	11.4	19%	
	20/02/2020	2800	540	5.2	-19%	1700	130	13.1	8%	
	9/07/2020	2800	620	4.5	19%	1700	130	13.1	-14%	
	10/08/2020	2800	600	4.7	16%	1600	120	13.3	-17%	Yes (Cl:SO4)
15/10/2020	2800	670	4.2	25%	1600	130	12.3	-8%	Yes (Cl:SO4)	
GW07	7/06/2018	5500	890	6.18	<i>I.D.</i>	3000	460	6.522	<i>I.D.</i>	
	17/01/2019	5700	1100	5.18	16%	2900	560	5.179	21%	
	19/02/2019	5700	1000	5.7	8%	2800	410	6.829	-5%	
	21/03/2019	5900	990	5.96	4%	3100	440	7.045	-8%	
	3/07/2019	5800	880	6.59	-27%	3100	390	7.949	-53%	
	9/01/2020	5700	1000	5.7	14%	3100	400	7.8	3%	
	26/02/2020	5600	890	6.3	5%	3100	390	7.9	0%	
	2/07/2020	5600	940	6	-5%	3100	390	7.9	-3%	
BORES REPRESENTATIVE OF BACKGROUND										
IWB2	18/10/2018	1200	160	7.5	6%	670	11	60.9	-7%	
	10/01/2019	1200	160	7.5	0%	660	11	60	7%	
	11/07/2019	1200	170	7.1	6%	650	9.2	70.7	-18%	
	14/01/2020	1200	160	7.5	-6%	670	9.7	69.1	2%	
	8/07/2020	1100	150	7.3	2%	610	9.5	64.2	7%	
IWB6	3/07/2018	350	200	1.8	3%	300	6.7	44.8	-5%	
	10/01/2019	360	220	1.6	6%	290	6.3	46	-3%	
	11/07/2019	350	190	1.8	-13%	300	6	50	-9%	
	14/01/2020	330	250	1.3	28%	340	7.2	47.2	6%	
	20/02/2020	340	190	1.8	3%	310	6.3	49.2	2%	
	8/07/2020	350	200	1.8	-33%	310	5.9	52.5	-11%	
BW53(Puls)	3/07/2018	790	270	2.9	-22%	530	34	15.6	-173%	
	10/01/2019	570	230	2.5	15%	350	37	9.5	39%	
	19/02/2019	860	330	2.6	11%	520	43	12.1	22%	Yes (Both)
	10/07/2019	840	310	2.7	-9%	530	29	18.3	-93%	

Bore ID	Date	Cl (mg/L)	SO4 (mg/L)	Cl:SO4 (Ratio)	% Red.	Na (mg/L)	Ca (mg/L)	Na:Ca (Ratio)	% Red.	Repeated ratio exceedance?
	13/01/2020	750	310	2.4	11%	500	29	17.2	6%	
	26/02/2020	770	310	2.5	8%	520	31	16.8	8%	
	9/07/2020	720	340	2.1	12%	490	25	19.6	-14%	
	17/08/2020	650	270	2.4	0%	460	27	17	1%	

NOTES

- Calculated ratios in green represent values that increase following an initial “>10%” reduction (i.e. no consecutive >10% reduction)
- Calculated ratios in red represent values above the “>10%” reduction threshold (initial identified exceedance).
- Calculated ratios in red highlight represent a confirmed “>10%” reduction in consecutive or follow-up samples
- I.D. = insufficient data to allow calculation of ionic ratio (only one data-point available)
- GW04 has previously been incorrectly referenced as being down gradient of Pit 23. Groundwater modelling and particle tracking per EMM (2019) indicate that GW04 is cross-gradient to the predicted groundwater flow path from Pit 23.
- BW28A is incorrectly referenced in the EMP (Revision 4) as being down-gradient of Pit 23. Groundwater modelling and particle tracking per CDM Smith (2014) and EMM (2019) indicate that BW28A is cross-gradient to the predicted groundwater flow path from Pit 23.

4.1.3.2 Radionuclide concentrations

In accordance with Section 7.6.7 of the EMP, biannual groundwater samples obtained from the monitoring locations are subjected to in-field and laboratory analysis for a suite of target parameters, which includes target radionuclides (Thorium, Uranium, Radium-226, Radium-228 and Uranium-238).

Radionuclide concentrations determined during both scheduled and follow-up sampling are presented in Table 4. Ionic balance ratios are also shown to identify any potential correlation with seepage from Pit 23. In summary:

- elevated results for Uranium-238 (U-238) were observed in the reporting period at bores GW03 (Down-gradient) and GW06 (Up-gradient). Follow up sampling at GW03 show the result of <0.025Bq/L returning to historical values, follow up results for GW06 are pending at the time of report preparation;
- an elevated Radium 228 (Ra-228) result was observed at bore BW45B (Cross-gradient) but is within historical values that are naturally elevated; and
- ionic balance ratios showed frequent fluctuation spatially and temporally, and between samples obtained over relatively short time periods, with no correlation to radionuclide concentrations. This suggests that the measured radionuclide concentrations and ‘exceedances’ are the product of natural variation, consistent with the findings of previous groundwater studies for the greater Douglas site (Jacobs 2014; CDM Smith 2014; EMM 2018).

The long-term trends in Ra-228 and U-238 concentrations verses ionic balance ratios are shown in Figure 7 – Figure 22. Consistent with the above summary, there is no evident correlation between elevated radionuclide concentrations and fluctuation or declining trends in Cl:SO4 or Na:Ca ratios.

It is recognised that this ionic balance ratio ‘percentage-reduction’ approach to trigger the completion of a groundwater investigation in the current endorsed EMP (Rev 4, July 2017) was based on limited available baseline data at the time of EMP development. This method is thus conservative and overly sensitive to natural variation and is likely to result in ‘false flag’ exceedances, as demonstrated in the McGlashin Swamp Seepage Exceedances Assessment completed by EMM during the 2018 reporting period (EMM, 2018). That is, the current approach does not consider trend-based change

in groundwater chemistry that accounts for seasonality or other influences on groundwater chemistry over a sufficient period of time. Revised site-specific trigger levels for groundwater quality, developed using the now expanded monitoring dataset and applying a trend-based trigger approach across all target analytes per the ANZECC/ARCMANZ (2000) guidelines, will therefore be implemented in the next revision of the EMP (Revision 5.1).

Table 4: Groundwater radionuclide concentrations vs. ionic balance ratios, H2 2020

Bore ID	Date	Thorium (mg/L)	Uranium (mg/L)	U-238 (Bq/L)	Ra226 (Bq/L)	Ra228 (Bq/L)	Cl:SO4		Na:Ca		Groundwater Travel Time (Years) *
							Ratio	% Red.	Ratio	% Red.	
Precautionary trigger		<i>n/a</i>	0.17	0.17	4.3	1.7	<i>n/a</i>	<i>n/a</i>	<i>n/a</i>	<i>n/a</i>	
Upper trigger		<i>n/a</i>	0.2	0.2	5	2	<i>n/a</i>	<i>n/a</i>	<i>n/a</i>	<i>n/a</i>	
BORES UP-GRADIENT OF PIT 23											
GW05	15/11/2018	<0.002	<0.002	<0.025	0.05	0.12	5.5	<i>I.D.</i>	10.6	<i>I.D.</i>	N/A – bores are up- gradient of Pit 23 Cl:SO4 and Na:Ca ratios shown to demonstrate natural variation only
	15/01/2019	<0.002	<0.002	<0.025	<0.05	0.09	4.8	13%	11	-4%	
	19/02/2019	<0.002	<0.002	<0.025	<0.05	<0.08	5	-10%	11.1	-5%	
	8/07/2019	<0.002	0.001	<0.025	0.02	<0.08	4.7	2%	13.6	-23%	
	15/01/2020	<0.002	<0.001	<0.025	0.03	0.13	4.1	14%	21.0	-55%	
	20/02/2020	<0.002	<0.001	<0.025	0.04	0.1	4.5	4%	21.8	-61%	
	9/07/2020	<0.002	<0.001	<0.025	0.04	0.11	4.2	-4%	22.6	-8%	
	17/08/2020	<0.002	<0.001	<0.025	0.07	0.16	4.4	-8%	17.9	15%	
GW06	12/06/2018	<0.002	0.072	0.037	0.11	0.14	4.4	<i>I.D.</i>	5.1	<i>I.D.</i>	
	14/01/2019	<0.002	0.105	1.3	0.05	0.22	3.9	10%	5.4	-5%	
	21/03/2019	<0.002	0.071	0.877	<0.05	0.09	4.2	-8%	5.5	-2%	
	17/04/2019	<0.002	0.089	1.1	0.06	0.19	4.7	-10%	5.5	0%	
	22/05/2019	<0.002	0.079	0.975	0.04	0.14	4.9	-4%	5.1	7%	
	18/06/2019	<0.002	0.003	<0.025	0.04	0.2	4.5	7%	5.9	-16%	
	4/07/2019	<0.002	0.072	0.889	0.06	0.17	4.5	0%	5.7	2%	
	22/01/2020	<0.002	0.003	0.025	0.04	0.21	3.8	17%	5.6	3%	
	24/02/2020	<0.002	0.003	1.33	0.16	0.08	4.5	1%	5.7	1%	
	6/07/2020	<0.002	0.003	0.667	0.05	0.19	4.3	-14%	5.9	-6%	
	20/01/2021	<0.002	0.003	Awaiting results			4.1	3%	6.0	-1%	
GW08	29/11/2018	<0.002	0.002	0.025	0.09	0.24	4.8	<i>I.D.</i>	7.2	<i>I.D.</i>	
	14/01/2019	<0.002	0.064	0.79	<0.05	<0.08	5.1	-5%	5.9	17%	

Bore ID	Date	Thorium	Uranium	U-238	Ra226	Ra228	CL:SO4		Na:Ca		Groundwater Travel Time (Years) *
		(mg/L)	(mg/L)	(Bq/L)	(Bq/L)	(Bq/L)	Ratio	% Red.	Ratio	% Red.	
Precautionary trigger		<i>n/a</i>	0.17	0.17	4.3	1.7	<i>n/a</i>	<i>n/a</i>	<i>n/a</i>	<i>n/a</i>	
Upper trigger		<i>n/a</i>	0.2	0.2	5	2	<i>n/a</i>	<i>n/a</i>	<i>n/a</i>	<i>n/a</i>	
	18/02/2019	<0.002	0.009	0.111	0.09	0.12	4.8	1%	6.1	15%	
	10/07/2019	<0.002	0.024	<0.025	0.04	0.08	5.9	-10%	6.5	-10%	
	20/01/2020	<0.003	0.001	2.86	0.07	<0.08	5.0	10%	6.5	0%	
	25/02/2020	<0.004	0.001	1.31	0.07	0.09	5.2	8%	6.7	-2%	
	5/05/2020	<0.002	<0.001	0.148	0.06	<0.08	5.2	6%	9.5	-45%	
	6/07/2020	<0.002	0.001	<0.025	0.06	<0.08	5.1	-2%	6.4	2%	
WRK301	10/07/2018	<0.002	0.008	0.049	0.14	0.17	6.5	-35%	6.5	4%	
	21/01/2019	<0.002	0.017	0.21	0.07	0.09	5	21%	5.9	10%	
	18/02/2019	<0.002	0.005	0.062	0.05	<0.08	4.9	24%	6.5	-12%	
	15/07/2019	<0.002	0.008	0.037	0.04	0.11	5.6	-11%	7.4	-26%	
	22/01/2020	0.0024	0.005	0.037	0.06	<0.08	5.2	8%	6.5	12%	
	25/02/2020	<0.002	0.005	0.395	0.01	<0.08	5.3	5%	6.7	10%	
	13/07/2020	<0.002	0.006	<0.025	<0.01	<0.08	5.3	-3%	6.9	-4%	
WRK302	10/07/2018	<0.002	0.059	0.148	0.19	0.76	5	-15%	6.7	8%	
	14/01/2019	<0.002	0.048	0.593	0.16	1.01	4.3	13%	7.1	-6%	
	18/02/2019	<0.002	0.046	0.568	0.31	1.14	4.8	4%	6.1	9%	
	21/03/2019	<0.002	0.116	1.43	0.27	0.94	4.4	12%	7.1	-6%	
	17/04/2019	<0.002	0.018	0.222	0.21	1.08	5.1	-2%	6.4	5%	
	22/05/2019	<0.002	<0.002	<0.025	0.12	0.84	5.1	-3%	6.9	-2%	
	4/07/2019	<0.002	0.001	0.086	0.24	0.91	4.6	-5%	7.8	-10%	
	1/08/2019	<0.002	<0.001	0.728	0.22	0.92	4.6	-7%	7.1	1%	
	20/01/2020	<0.002	<0.001	0.296	0.34	1.02	4.1	10%	7.6	3%	
	6/07/2020	<0.002	<0.001	0.049	0.18	0.74	4.4	-7%	6.5	14%	
	3/09/2020	<0.002	<0.001	0.16	0.33	0.91	4.5	-9%	7.7	-1%	

Bore ID	Date	Thorium	Uranium	U-238	Ra226	Ra228	CL:SO4		Na:Ca		Groundwater Travel Time (Years) *
		(mg/L)	(mg/L)	(Bq/L)	(Bq/L)	(Bq/L)	Ratio	% Red.	Ratio	% Red.	
Precautionary trigger		<i>n/a</i>	0.17	0.17	4.3	1.7	<i>n/a</i>	<i>n/a</i>	<i>n/a</i>	<i>n/a</i>	
Upper trigger		<i>n/a</i>	0.2	0.2	5	2	<i>n/a</i>	<i>n/a</i>	<i>n/a</i>	<i>n/a</i>	
WRK303	10/07/2018	<0.002	<0.002	<0.025	<0.06	<0.09	4.2	-10%	12.7	5%	
	14/01/2019	<0.002	<0.002	<0.025	<0.05	<0.08	4	4%	11.5	9%	
	15/07/2019	<0.002	<0.001	<0.025	0.04	<0.08	4.7	-17%	13.3	-16%	
	23/01/2020	<0.002	<0.001	<0.025	0.03	<0.08	4.8	-2%	12.9	4%	
	13/07/2020	<0.002	<0.001	<0.025	0.04	0.09	4.8	0%	11.3	12%	
	19/08/2020	0.006	0.004	<0.025	0.03	<0.08	4.9	-2%	13.3	-4%	
WRK304	10/07/2018	<0.002	<0.002	<0.025	<0.05	<0.08	3.4	0%	15.1	-3%	
	14/01/2019	<0.002	<0.002	<0.025	<0.05	<0.08	3.2	6%	16.1	-7%	
	15/07/2019	<0.002	<0.001	<0.025	0.02	<0.08	3.8	-16%	16	1%	
	22/01/2020	<0.002	<0.001	2.7	<0.01	<0.08	3.6	5%	17	-7%	
	5/03/2020	<0.002	<0.001	<0.025	<0.01	<0.08	3.9	-4%	14.5	9%	
	14/07/2020	<0.002	<0.001	<0.025	0.02	<0.08	3.7	-3%	14.5	14%	
	19/08/2020	0.006	0.004	<0.025	0.01	<0.08	3.9	-9%	12.7	25%	
BORES DOWN-GRADIENT OF PIT 23 (IN PREDICTED FLOW PATH)											
BW36A	11/12/2019	<0.002	0.002	<0.025	0.07	0.17	7.5	<i>I.D.</i>	10	<i>I.D.</i>	36 years
	16/01/2020	<0.002	<0.001	<0.025	<0.01	<0.08	13.3	-78%	11.2	-12%	
	7/07/2020	<0.002	<0.001	<0.025	0.06	0.15	7.9	41%	10.0	10%	
	17/08/2020	<0.002	<0.001	0.037	0.06	0.2	9.5	28%	11.8	-6%	
WRK300	18/10/2018	<0.002	<0.001	<i>N.S.</i>	<i>N.S.</i>	<i>N.S.</i>	5.5	-3%	7	-5%	
	21/01/2019	<0.002	<0.002	<0.025	<0.05	<0.08	6	-9%	6.1	3%	
	18/02/2019	<0.002	<0.002	<0.025	<0.05	<0.08	5.2	7%	7	-11%	
	21/03/2019	<0.002	0.002	<0.025	<0.05	<0.08	5.8	-5%	5.6	12%	
	17/04/2019	<0.002	<0.002	<0.025	0.03	0.09	6.2	-13%	6.5	-3%	
	16/07/2019	<0.002	<0.002	<0.025	0.03	<0.08	5.7	6%	7.6	-26%	

Bore ID	Date	Thorium (mg/L)	Uranium (mg/L)	U-238 (Bq/L)	Ra226 (Bq/L)	Ra228 (Bq/L)	CL:SO4		Na:Ca		Groundwater Travel Time (Years) *
							Ratio	% Red.	Ratio	% Red.	
Precautionary trigger		<i>n/a</i>	0.17	0.17	4.3	1.7	<i>n/a</i>	<i>n/a</i>	<i>n/a</i>	<i>n/a</i>	
Upper trigger		<i>n/a</i>	0.2	0.2	5	2	<i>n/a</i>	<i>n/a</i>	<i>n/a</i>	<i>n/a</i>	
	16/01/2020	<0.002	0.001	<0.025	0.02	0.08	5.5	3%	7.3	4%	
	13/07/2020	<0.002	<0.001	<0.025	0.03	<0.08	5.3	3%	6.6	9%	
GW01	7/06/2018	<0.002	<0.001	<0.025	<0.05	<0.08	8.4	<i>I.D.</i>	6	<i>I.D.</i>	88 years
	15/01/2019	<0.002	<0.001	<0.025	0.48	1.36	8.5	-1%	27.7	-363%	
	20/03/2019	<0.002	0.001	<0.025	0.48	0.72	8.3	2%	29.4	-6%	
	15/04/2019	<0.002	<0.001	<0.025	0.4	1.2	10	-18%	25.3	9%	
	14/05/2019	0.0095	0.009	<0.025	0.47	1.36	9.4	-11%	32.8	-18%	
	18/06/2019	<0.002	<0.002	<0.025	0.46	1.29	8	5%	32.1	-16%	
	8/07/2019	<0.002	0.002	<0.025	0.28	0.77	8.5	0%	32.7	-18%	
	15/01/2020	<0.002	<0.001	<0.025	0.32	0.81	7.4	12%	20.7	37%	
	20/02/2020	<0.002	<0.001	<0.025	0.32	0.9	7.6	11%	26.0	21%	
	7/07/2020	<0.002	<0.001	<0.025	0.24	0.72	6.6	11%	24.4	-18%	
	10/08/2020	<0.002	<0.001	<0.025	0.13	0.42	7.7	-4%	23.1	-12%	
GW02	28/11/2018	<0.002	<0.001	<0.025	0.05	0.11	5.1	<i>I.D.</i>	34.2	<i>I.D.</i>	144 years
	15/01/2019	<0.002	<0.001	<0.025	0.05	0.15	6	-18%	46.1	-35%	
	10/07/2019	<0.002	<0.001	0.296	0.1	0.32	7	-15%	61.9	-34%	
	14/01/2020	<0.002	<0.001	<0.025	0.05	0.14	6.2	11%	63.2	-2%	
	3/03/2020	0.004	<0.001	<0.025	0.08	0.27	6.9	1%	70.6	-14%	
	2/07/2020	<0.002	<0.001	<0.025	0.1	0.33	5.0	19%	57.1	10%	
	10/08/2020	<0.002	<0.001	<0.025	0.09	0.31	5.7	8%	63.2	0%	
GW03	28/11/2018	<0.002	<0.002	0.025	0.07	0.16	5.7	<i>I.D.</i>	9.5	<i>I.D.</i>	176 years
	15/01/2019	<0.002	<0.002	<0.025	<0.05	<0.08	5.3	8%	7	26%	
	19/02/2019	<0.002	<0.002	<0.025	<0.05	<0.08	5.6	-6%	10	-6%	
	10/07/2019	<0.002	<0.001	<0.025	0.01	<0.08	6.3	-20%	11.2	-59%	

Bore ID	Date	Thorium (mg/L)	Uranium (mg/L)	U-238 (Bq/L)	Ra226 (Bq/L)	Ra228 (Bq/L)	Cl:SO4		Na:Ca		Groundwater Travel Time (Years) *
							Ratio	% Red.	Ratio	% Red.	
Precautionary trigger		<i>n/a</i>	0.17	0.17	4.3	1.7	<i>n/a</i>	<i>n/a</i>	<i>n/a</i>	<i>n/a</i>	
Upper trigger		<i>n/a</i>	0.2	0.2	5	2	<i>n/a</i>	<i>n/a</i>	<i>n/a</i>	<i>n/a</i>	
	14/01/2020	<0.002	<0.001	<0.025	0.01	<0.08	6	5%	11.3	-1%	
	2/07/2020	<0.002	<0.001	0.864	0.01	<0.08	5.8	4%	11.2	1%	
	14/01/2021	0.008	<0.001	<0.025	<0.05	<0.08	5.2	10%	11.1	1%	
GW04A	<i>New bore installed in Oct 2020</i>										
	30/11/2020	<0.002	<0.001	<0.025	0.04	0.2	6.4	<i>I.D.</i>	10.8	<i>I.D.</i>	
BW05	18/10/2018	<0.002	0.03	<0.025	<0.05	<0.08	11	-23%	18.8	-11%	500+ years
	17/01/2019	<0.002	0.004	0.037	<0.05	<0.08	8.6	17%	15.5	35%	
	20/03/2019	<0.002	0.003	0.049	<0.05	<0.08	9.4	10%	18.1	24%	
	3/07/2019	<0.002	0.003	<0.025	0.03	<0.08	9.6	-12%	19.2	-24%	
	13/01/2020	<0.002	0.002	<0.025	<0.01	<0.08	9.0	7%	19.6	-2%	
	8/07/2020	<0.002	0.004	<0.025	0.03	<0.08	9.0	0%	18.1	8%	
BORES CROSS-GRADIENT OF PIT 23											
BW28A *	20/08/2018	<0.002	0.005	0.074	0.09	<0.08	8.3	-14%	7	7%	N/A - Bores not on flow path from Pit 23 Cl:SO4 and Na:Ca ratios shown to demonstrate natural variation only
	17/01/2019	<0.002	0.005	1.48	0.13	<0.08	7.1	9%	6.5	2%	
	18/02/2019	<0.002	0.005	0.173	0.17	<0.08	6.5	16%	6.9	-5%	
	3/07/2019	<0.002	0.006	0.679	0.13	<0.08	7.7	-9%	7.2	-11%	
	13/01/2020	<0.002	0.006	2.16	0.1	<0.08	7.2	7%	7.4	-3%	
	26/02/2020	<0.002	0.007	0.234	0.12	<0.08	8.2	-7%	7.3	-2%	
	8/07/2020	<0.002	0.007	<0.025	0.11	<0.08	7.7	-7%	7.0	5%	
	10/08/2020	<0.002	0.007	0.148	0.11	<0.08	8.2	-14%	6.7	10%	
BW45B	29/11/2018	<0.002	<0.001	<0.025	0.22	0.86	5.6	<i>I.D.</i>	8.6	<i>I.D.</i>	
	17/01/2019	<0.002	0.001	<0.025	0.42	2.4	5.3	7%	7.8	9%	
	6/03/2019	<0.002	0.001	<0.025	0.45	2.6	5.6	2%	8	6%	
	20/03/2019	<0.002	0.012	0.037	0.83	2.77	5.5	3%	8.4	2%	

Bore ID	Date	Thorium	Uranium	U-238	Ra226	Ra228	CL:SO4		Na:Ca		Groundwater Travel Time (Years) *
		(mg/L)	(mg/L)	(Bq/L)	(Bq/L)	(Bq/L)	Ratio	% Red.	Ratio	% Red.	
Precautionary trigger		<i>n/a</i>	0.17	0.17	4.3	1.7	<i>n/a</i>	<i>n/a</i>	<i>n/a</i>	<i>n/a</i>	
Upper trigger		<i>n/a</i>	0.2	0.2	5	2	<i>n/a</i>	<i>n/a</i>	<i>n/a</i>	<i>n/a</i>	
	15/04/2019	<0.002	0.005	0.667	0.53	3.08	6.7	-17%	8.7	-1%	
	14/05/2019	<0.002	0.015	0.099	0.63	2.94	5.9	-3%	9	-5%	
	18/06/2019	<0.002	0.012	0.222	0.69	3.4	6.2	-8%	9.3	-8%	
	8/07/2019	<0.002	0.014	0.148	0.72	3.18	5.8	-9%	9	-16%	
	14/08/2019	<0.002	0.002	0.025	0.52	2.2	5.7	-7%	8.1	-4%	
	15/01/2020	<0.002	0.006	0.099	0.51	2.81	5.3	8%	8.75	-8%	
	26/02/2020	<0.002	<0.001	0.086	0.52	2.9	6.3	-8%	9	-11%	
	7/07/2020	<0.002	0.017	0.198	0.69	3.02	5.8	-8%	8.8	0%	
	19/08/2020	0.006	0.01	<0.025	0.58	2.36	6.3	-18%	8.4	4%	
GW04	28/11/2018	<0.002	<0.002	<0.025	0.07	0.15	3.9	<i>I.D.</i>	14.2	<i>I.D.</i>	
	15/01/2019	<0.002	<0.002	<0.025	0.09	0.19	3.9	1%	17.3	-22%	
	8/07/2019	<0.002	<0.001	<0.002	0.1	0.2	4.4	-13%	14.2	18%	
	1/08/2019	<0.002	<0.001	<0.025	0.13	0.24	5.3	-35%	11.4	34%	
	12/09/2019	<0.002	<0.001	<0.025	0.12	0.24	4.3	-10%	13.1	24%	
	15/01/2020	<0.002	<0.001	<0.025	0.1	0.25	5.6	-27%	11.4	19%	
	20/02/2020	<0.002	<0.001	<0.025	0.14	0.26	5.2	-19%	13.1	8%	
	9/07/2020	<0.002	<0.001	<0.025	0.12	0.24	4.5	19%	13.1	-14%	
	10/08/2020	<0.002	<0.001	<0.025	0.12	0.25	4.7	16%	13.3	-17%	
	15/10/2020	<0.002	<0.001	<0.025	0.12	0.25	4.2	25%	12.3	-8%	
GW07	7/06/2018	<0.002	0.001	<0.025	<0.05	<0.08	6.2	<i>I.D.</i>	6.5	<i>I.D.</i>	
	17/01/2019	<0.002	<0.001	0.296	0.06	0.32	5.2	16%	5.2	21%	
	19/02/2019	<0.002	<0.001	0.556	<0.05	0.28	5.7	8%	6.8	-5%	
	21/03/2019	<0.002	<0.001	<0.025	<0.05	0.12	6	4%	7	-8%	
	3/07/2019	<0.002	<0.001	0.259	0.06	0.2	6.6	-27%	7.9	-53%	

Bore ID	Date	Thorium	Uranium	U-238	Ra226	Ra228	CL:SO4		Na:Ca		Groundwater Travel Time (Years) *
		(mg/L)	(mg/L)	(Bq/L)	(Bq/L)	(Bq/L)	Ratio	% Red.	Ratio	% Red.	
Precautionary trigger		<i>n/a</i>	0.17	0.17	4.3	1.7	<i>n/a</i>	<i>n/a</i>	<i>n/a</i>	<i>n/a</i>	
Upper trigger		<i>n/a</i>	0.2	0.2	5	2	<i>n/a</i>	<i>n/a</i>	<i>n/a</i>	<i>n/a</i>	
	9/01/2020	<0.002	<0.001	2.04	0.08	0.19	5.7	14%	7.8	3%	
	26/02/2020	<0.002	<0.001	0.037	0.07	0.24	6.3	5%	7.9	0%	
	2/07/2020	<0.002	<0.001	0.123	0.07	0.34	6.0	-5%	7.9	-3%	
BORES REPRESENTATIVE OF BACKGROUND											
IWB2	18/10/2018	<0.002	<0.001	<0.025	0.03	<0.08	7.5	6%	60.9	-7%	N/A - Bores not on flow path from Pit 23
	10/01/2019	<0.002	<0.001	<0.025	<0.05	0.08	7.5	0%	60	7%	
	11/07/2019	<0.002	<0.001	<0.025	0.03	<0.08	7	6%	70.6	-18%	
	14/01/2020	<0.002	<0.001	<0.025	0.06	0.12	7.5	-6%	69.1	2%	
	8/07/2020	<0.002	<0.001	<0.025	0.01	<0.08	7.3	2%	64.2	7%	
IWB6	3/07/2018	<0.002	<0.001	0.037	<0.05	<0.08	1.7	3%	44.8	-5%	
	10/01/2019	<0.002	<0.001	<0.025	<0.05	<0.08	1.7	6%	46	-3%	
	11/07/2019	<0.002	<0.001	<0.025	0.02	<0.08	1.8	-13%	50	-9%	
	14/01/2020	<0.002	<0.001	<0.025	0.03	<0.08	1.3	28%	47.2	6%	
	20/02/2020	<0.002	<0.001	<0.025	0.02	<0.08	1.8	3%	49.2	2%	
	8/07/2020	<0.002	<0.001	<0.025	0.02	<0.08	1.8	-33%	52.5	-11%	
BW53 ("Puls")	3/07/2018	<0.002	<0.001	<0.025	<0.05	0.11	2.9	-22%	15.6	-173%	
	10/01/2019	<0.002	<0.001	<0.025	<0.05	0.19	2.5	15%	9.6	39%	
	19/02/2019	<0.002	<0.001	<0.025	<0.05	0.16	2.6	11%	12.1	22%	
	10/07/2019	<0.002	<0.001	<0.025	0.04	0.11	2.7	-9%	18.3	-93%	
	13/01/2020	<0.002	<0.002	<0.025	0.04	0.12	2.4	11%	17.2	6%	
	26/02/2020	<0.002	<0.002	<0.025	0.03	0.17	2.5	8%	16.8	8%	
	9/07/2020	<0.002	<0.001	<0.025	0.04	0.1	2.1	12%	19.6	-14%	
	17/08/2020	<0.002	<0.001	0.037	0.03	0.1	2.4	0%	17.0	1%	
NOTES											

Bore ID	Date	Thorium (mg/L)	Uranium (mg/L)	U-238 (Bq/L)	Ra226 (Bq/L)	Ra228 (Bq/L)	CL:SO4		Na:Ca		Groundwater Travel Time (Years) *
							Ratio	% Red.	Ratio	% Red.	
Precautionary trigger		<i>n/a</i>	<i>0.17</i>	<i>0.17</i>	<i>4.3</i>	<i>1.7</i>	<i>n/a</i>	<i>n/a</i>	<i>n/a</i>	<i>n/a</i>	
Upper trigger		<i>n/a</i>	<i>0.2</i>	<i>0.2</i>	<i>5</i>	<i>2</i>	<i>n/a</i>	<i>n/a</i>	<i>n/a</i>	<i>n/a</i>	

- < = results below the laboratory limit of detection. These are treated as a negative (-) concentrations in figures presented in this report to allow graphical representation.
- Results highlighted in **orange** indicate an exceedance of the precautionary trigger
- Results highlighted in **pink** indicate an exceedance of the upper trigger
- Calculated ratios in green represent values that increase following an initial ">10%" reduction (i.e. no consecutive >10% reduction)
- Calculated ratios in red represent values above the ">10%" reduction threshold (initial identified exceedance).
- Calculated ratios in red highlight represent a confirmed ">10%" reduction in consecutive or follow-up samples
- N.S. = not sampled / analysed
- I.D. = insufficient data to allow calculation of ionic ratio (only one data-point available)
- Groundwater arrival year is based on groundwater model predictions (particle tracking) per CDM Smith (2015) and EMM (2019), and assumes that groundwater flow originates from Pit 23 immediately on commencement of the first by-product disposal to into Pit 23 (December 2011).
- GW04 is incorrectly referenced in the EMP (Revision 4) as being down gradient of Pit 23. Groundwater modelling and particle tracking per EMM (2019) indicate that GW04 is cross-gradient to the predicted groundwater flow path from Pit 23.
- BW28A is incorrectly referenced in the EMP (Revision 4) as being down-gradient of Pit 23. Groundwater modelling and particle tracking per CDM Smith (2014) and EMM (2019) indicate that BW28A is cross-gradient to the predicted groundwater flow path from Pit 23.

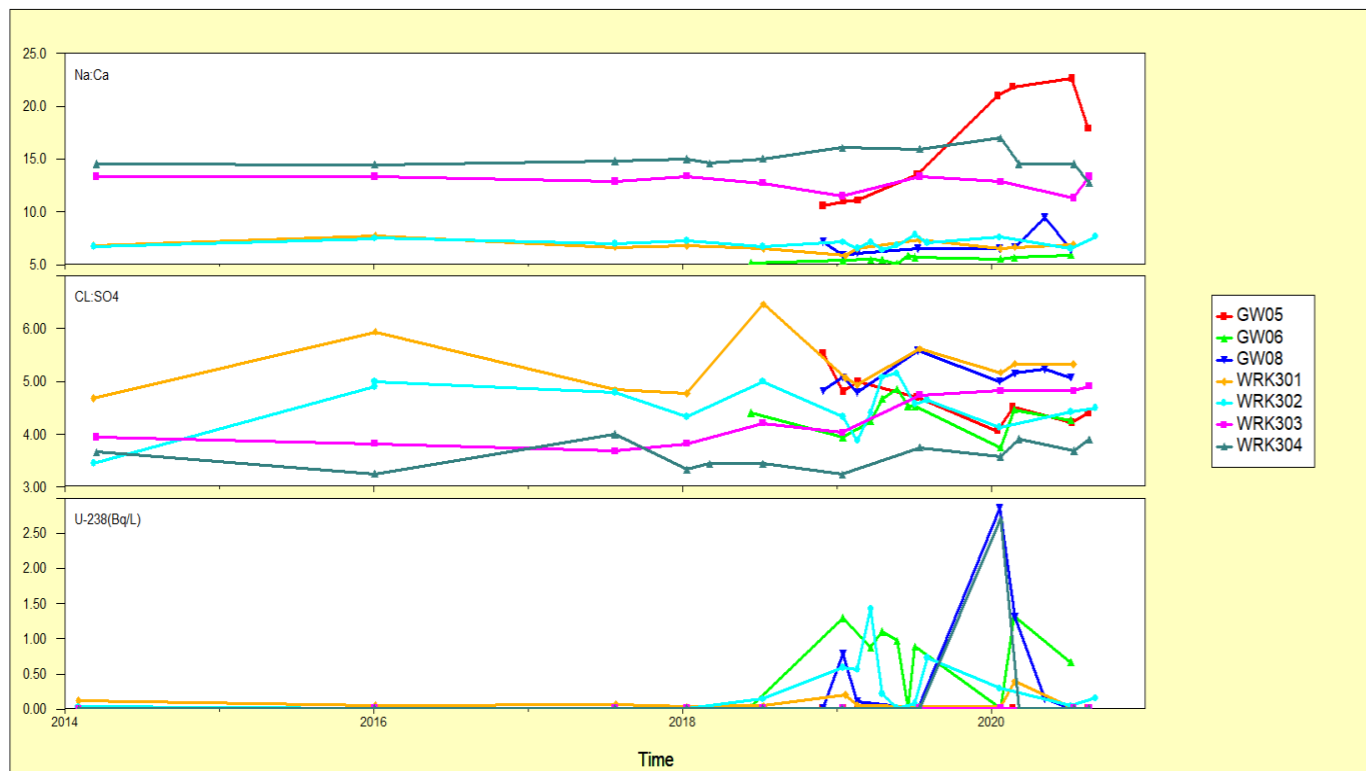

Figure 7: U-238 and ionic balance trends – up-gradient bores (1 of 2)

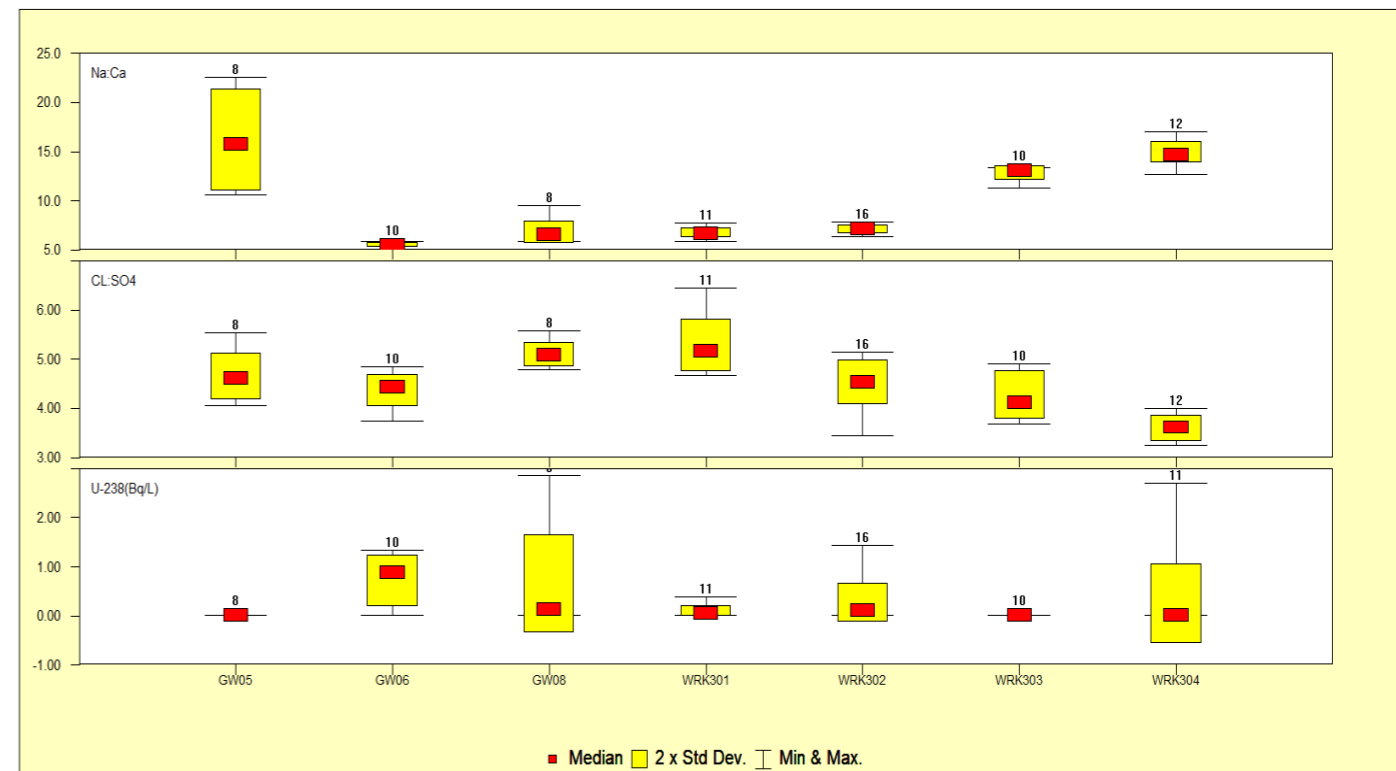

Figure 8: U-238 and ionic balance trends – up-gradient bores (2 of 2)

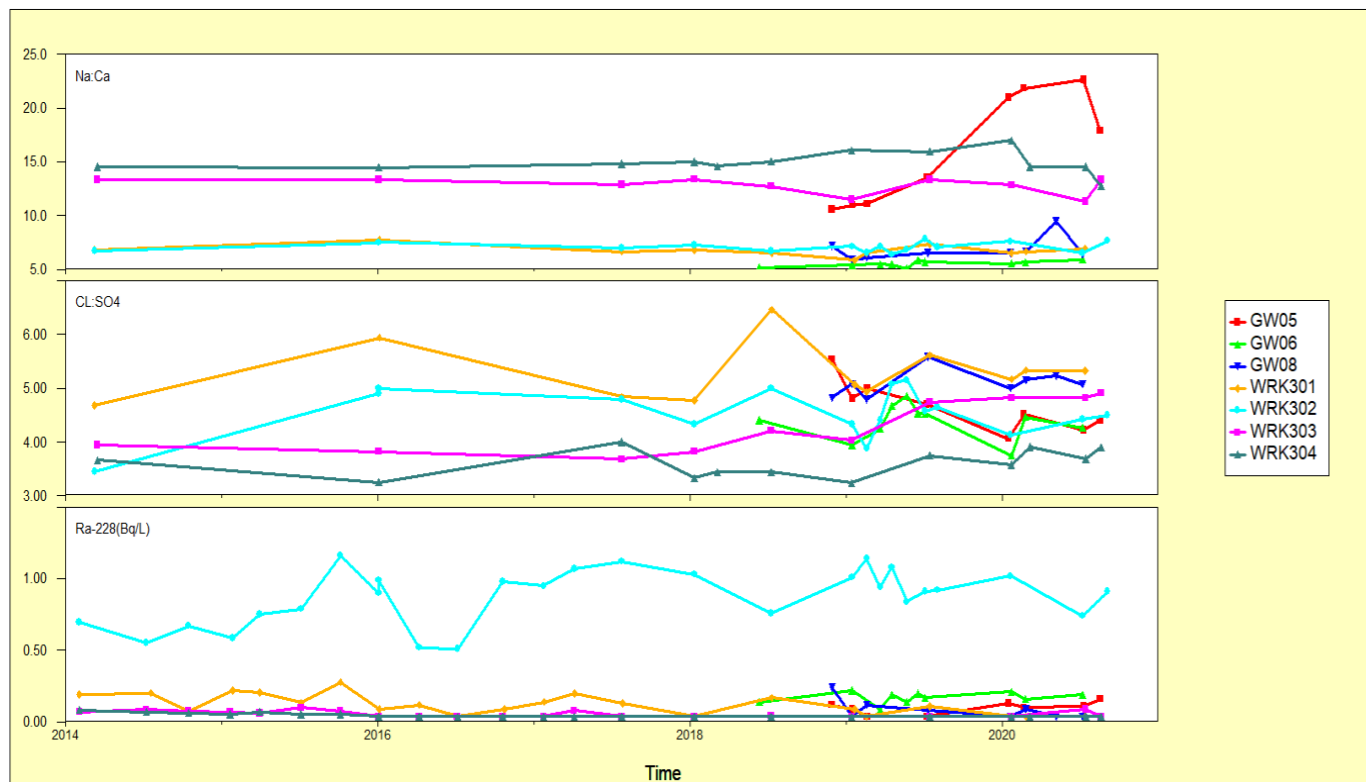

Figure 9: Ra-228 and ionic balance trends – up-gradient bores (1 of 2)s

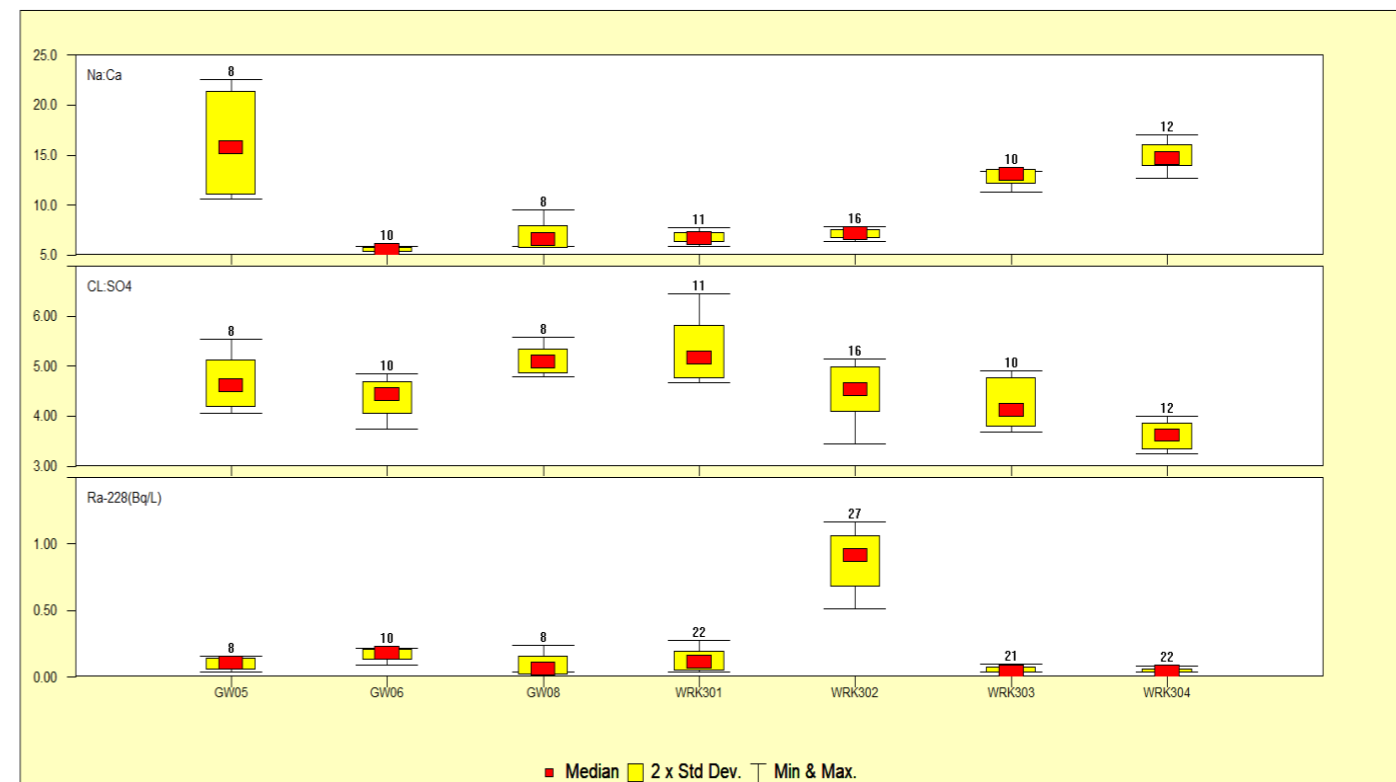

Figure 10: Ra-228 and ionic balance trends – up-gradient bores (2 of 2)

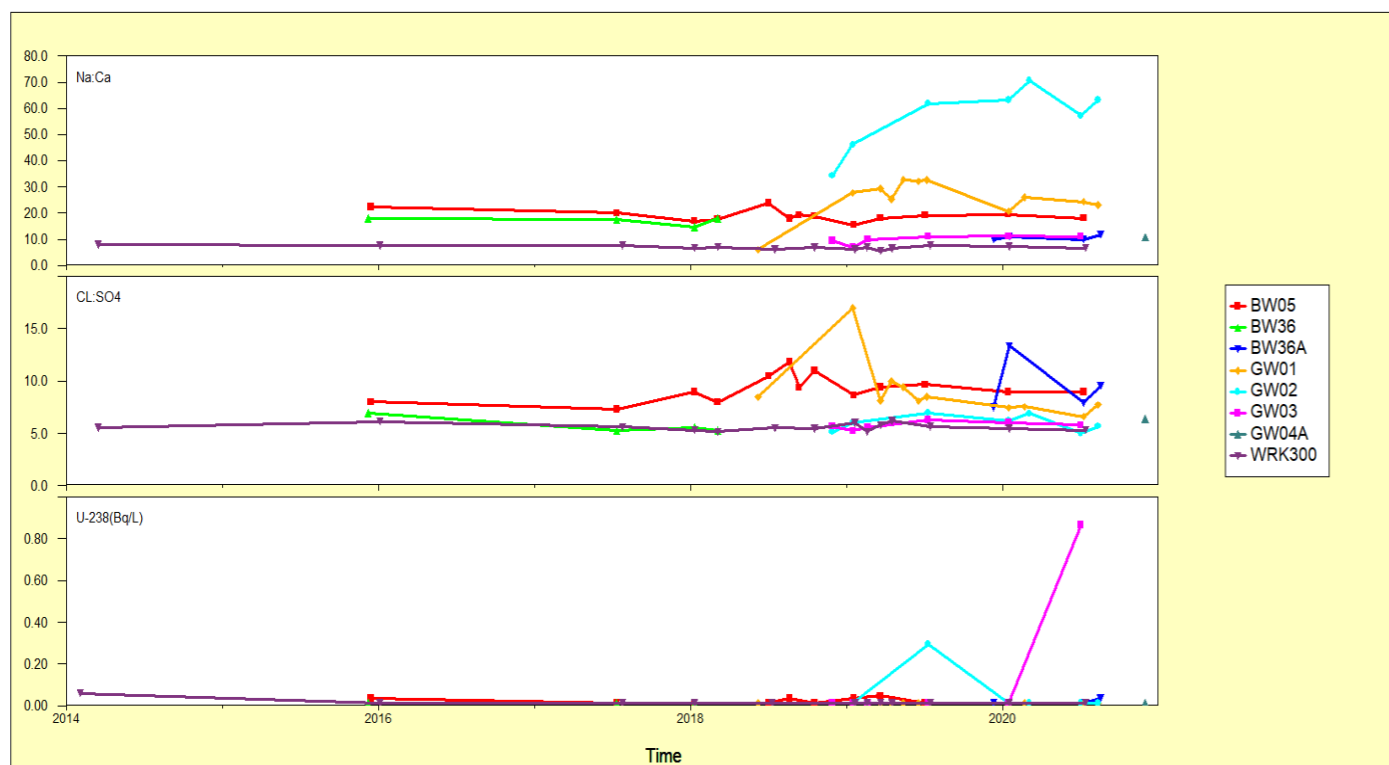

Figure 11: U-238 and ionic balance trends – down-gradient bores (1 of 2)

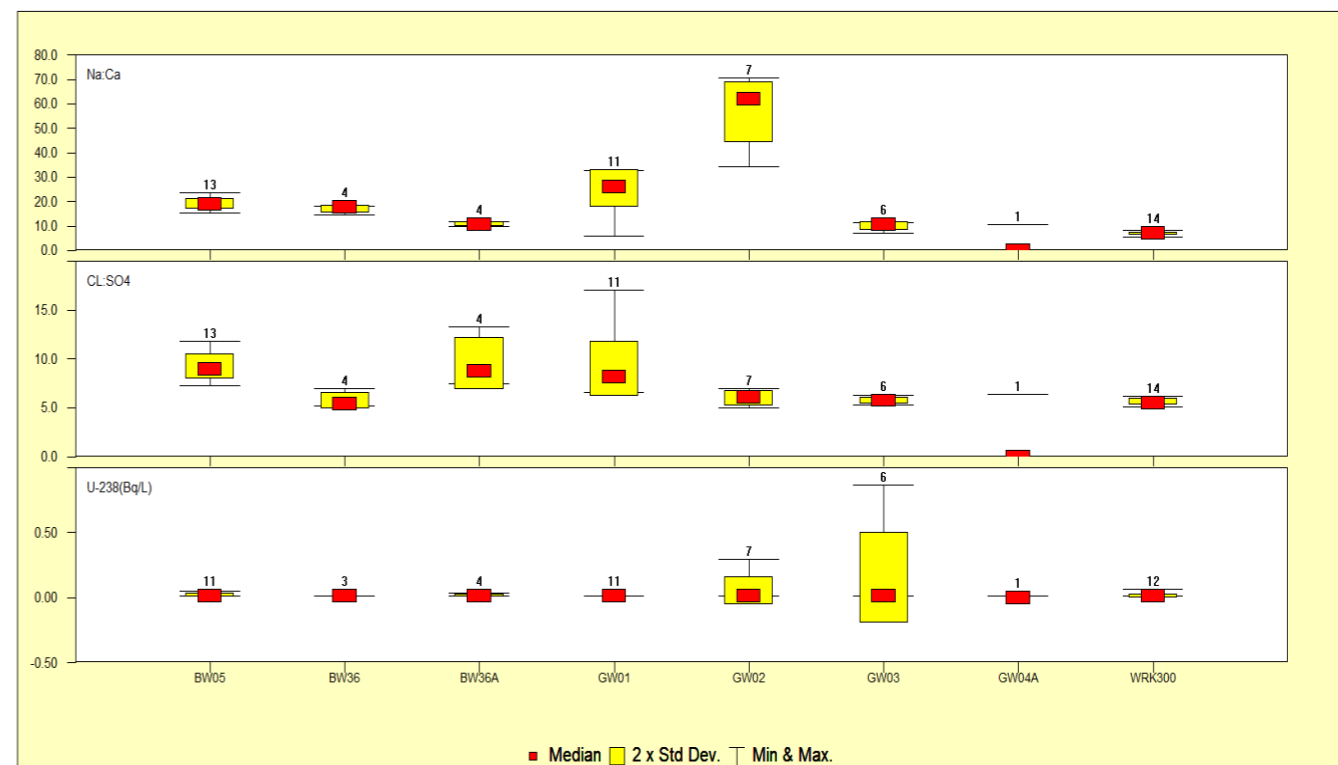

Figure 12: U-238 and ionic balance trends – down-gradient bores (2 of 2)

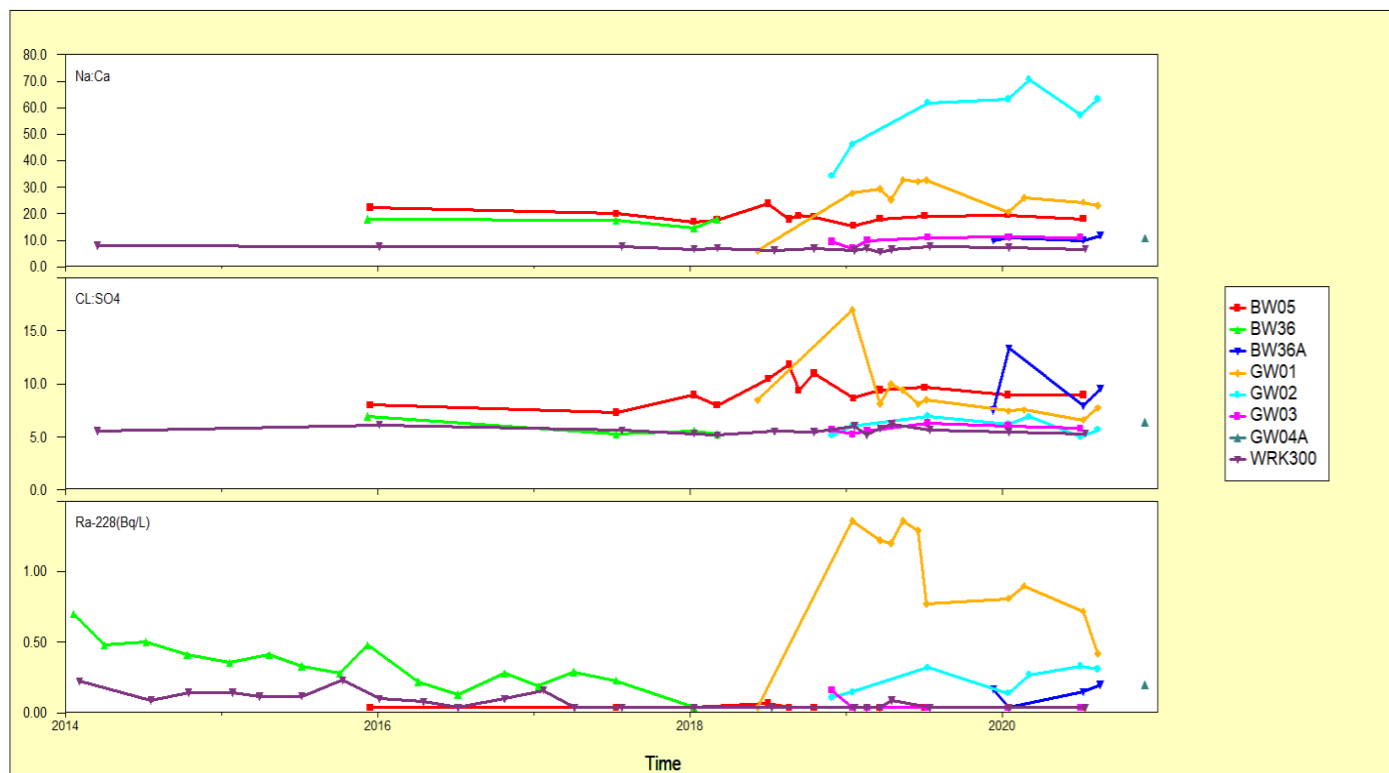

Figure 13: Ra-228 and ionic balance trends – down-gradient bores (1 of 2)

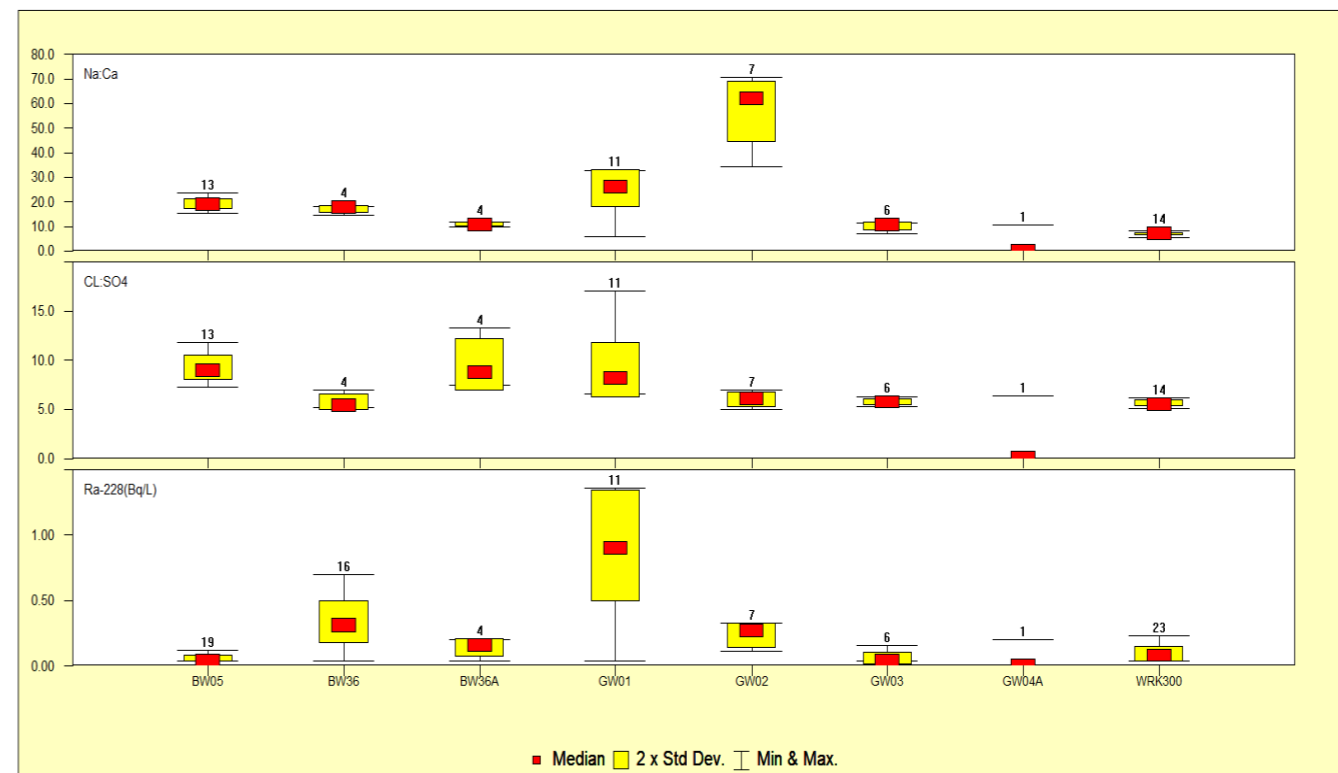

Figure 14: Ra-228 and ionic balance trends – down-gradient bores (2 of 2)

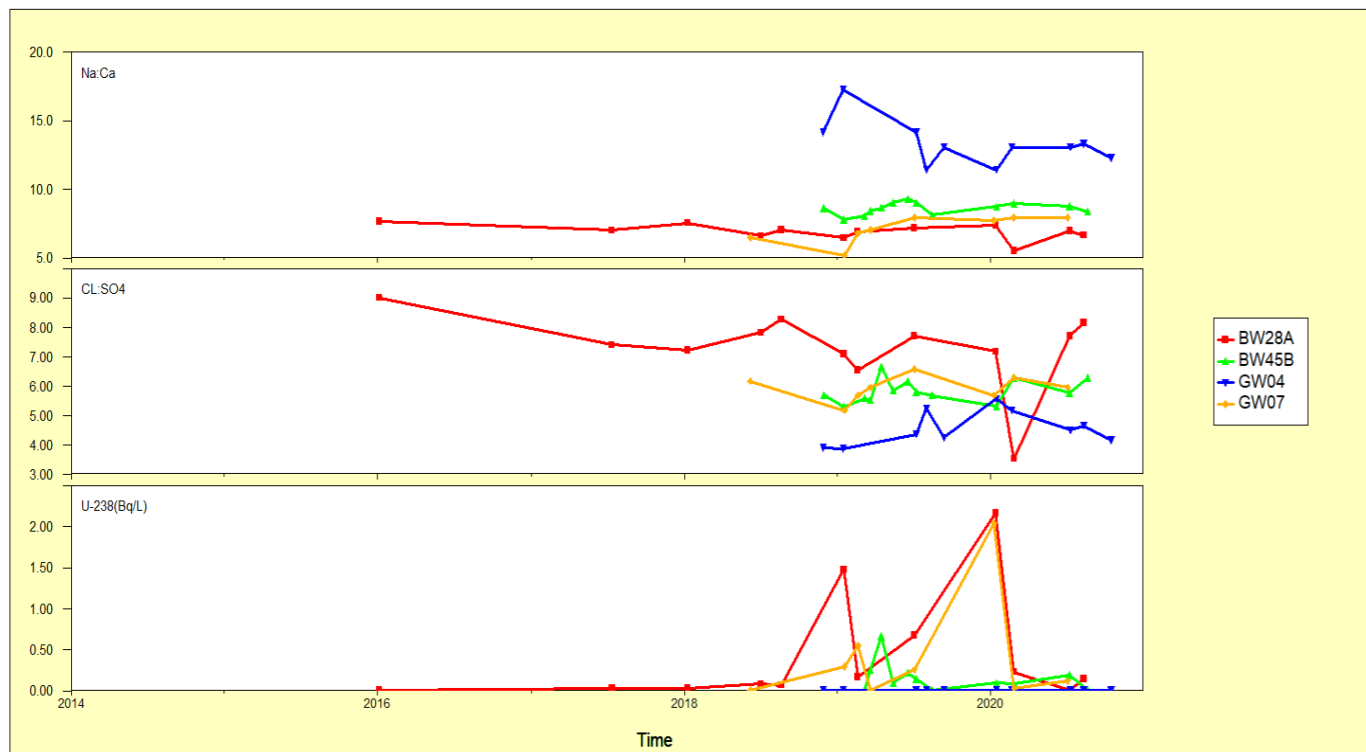

Figure 15: U-238 and ionic balance trends – cross-gradient bores (1 of 2)

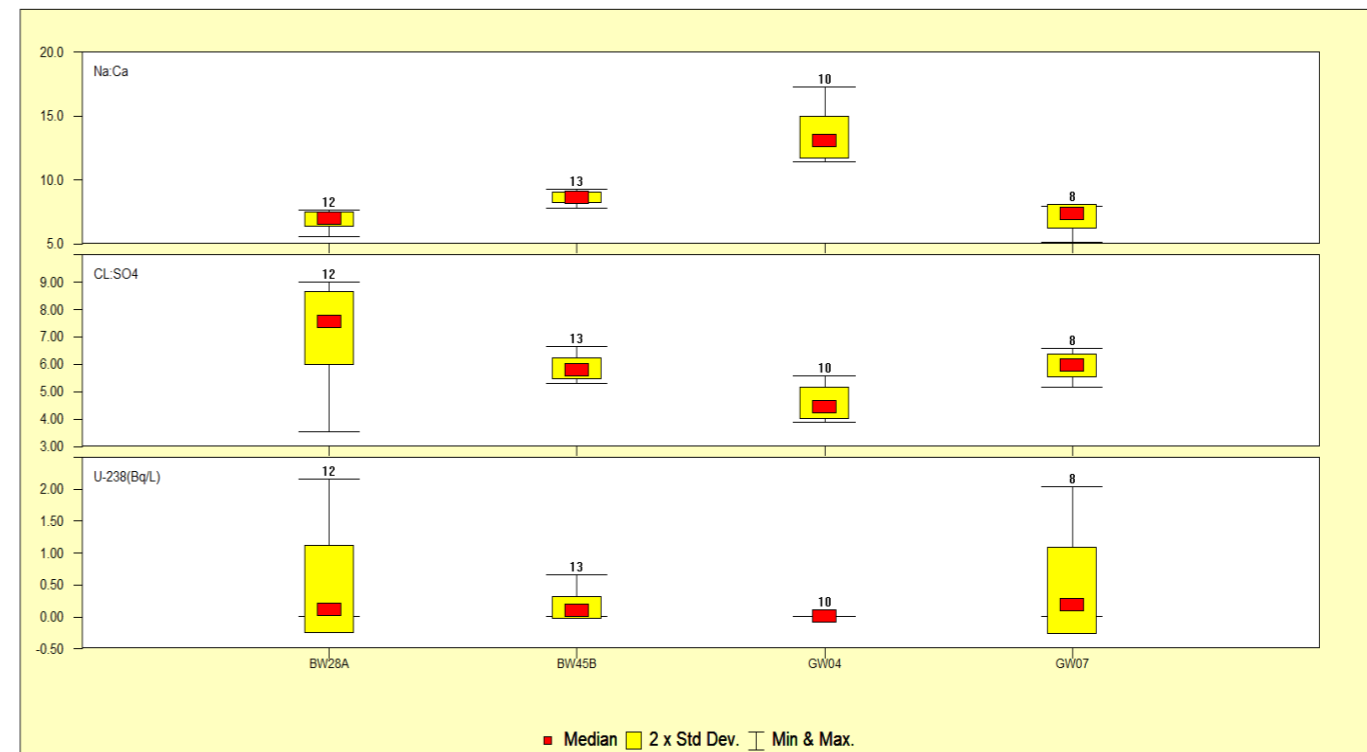

Figure 16: U-238 and ionic balance trends – cross-gradient bores (2 of 2)

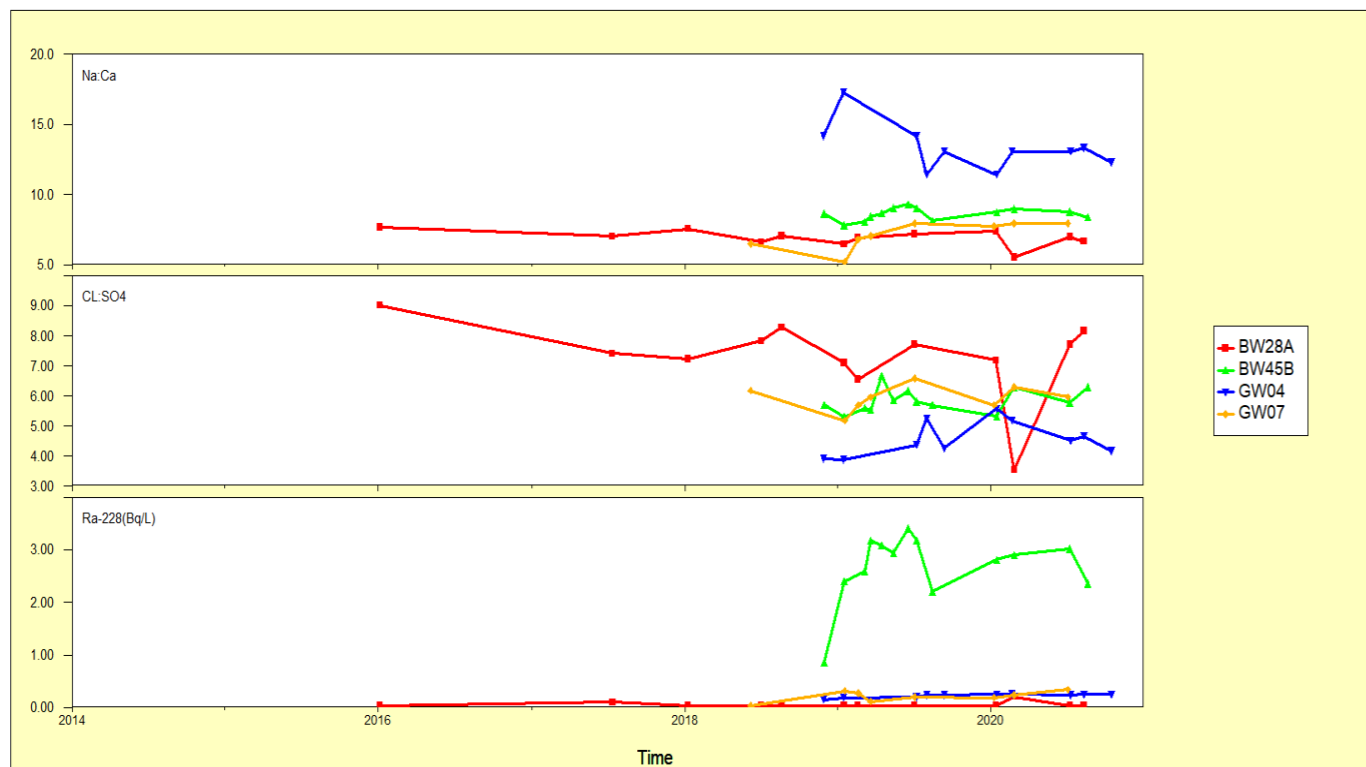

Figure 17: Ra-228 and ionic balance trends – cross-gradient bores (1 of 2)

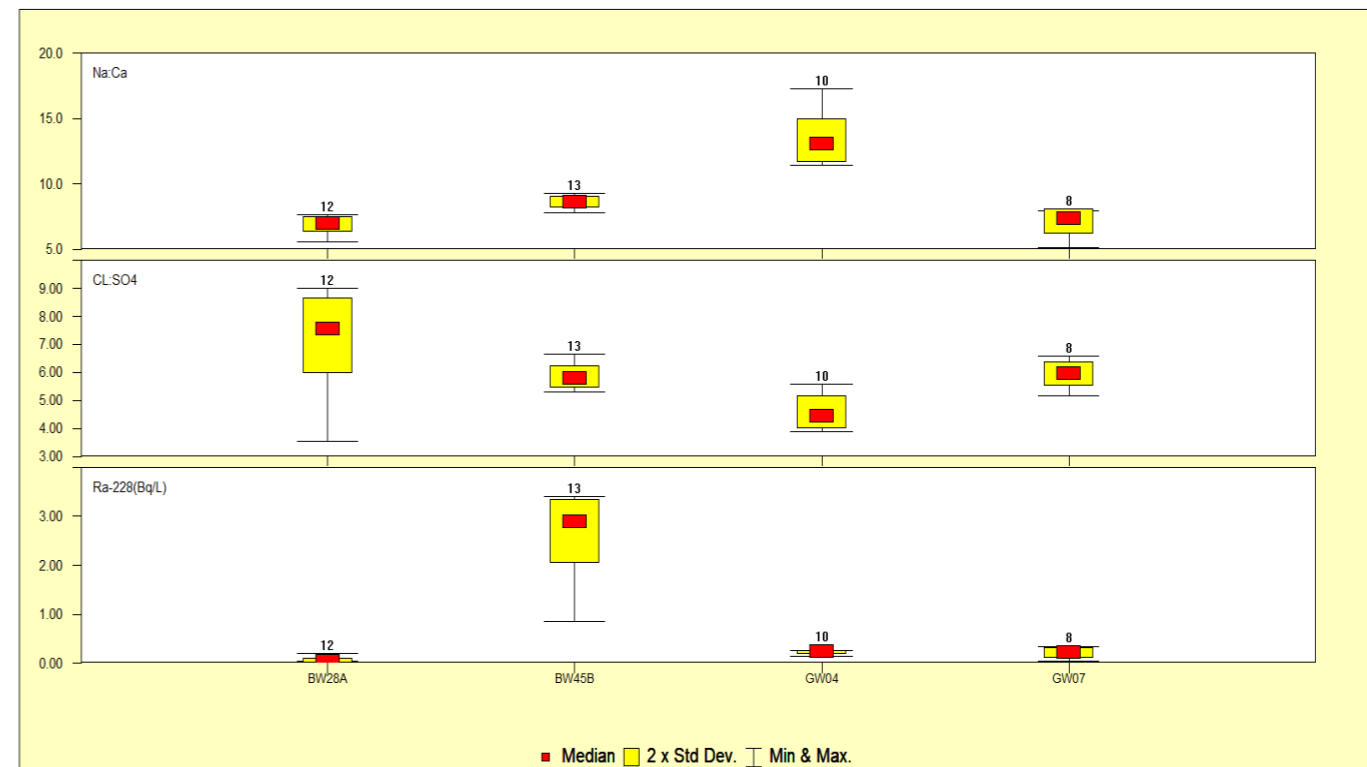

Figure 18: Ra-228 and ionic balance trends – cross-gradient bores (2 of 2)

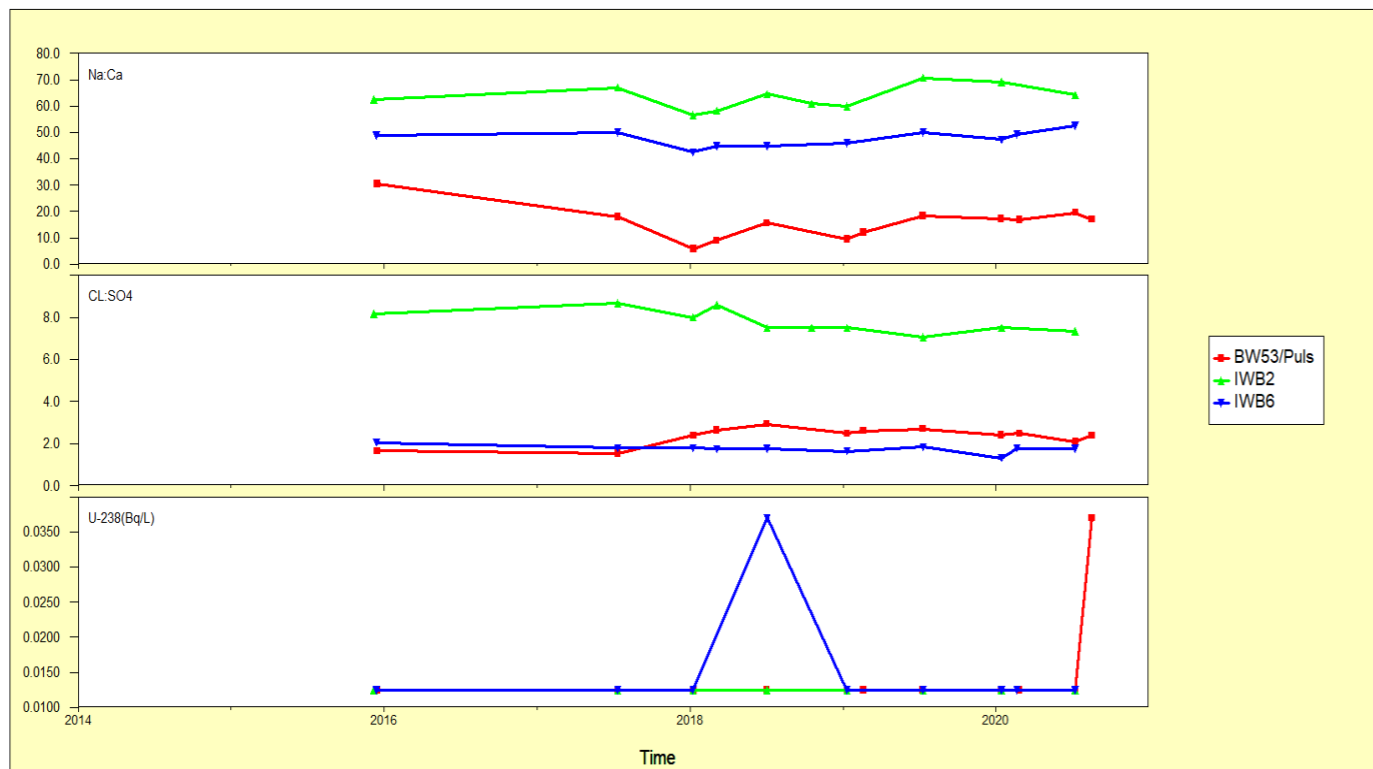

Figure 19: U-238 and ionic balance trends – bores representing background (1 of 2)

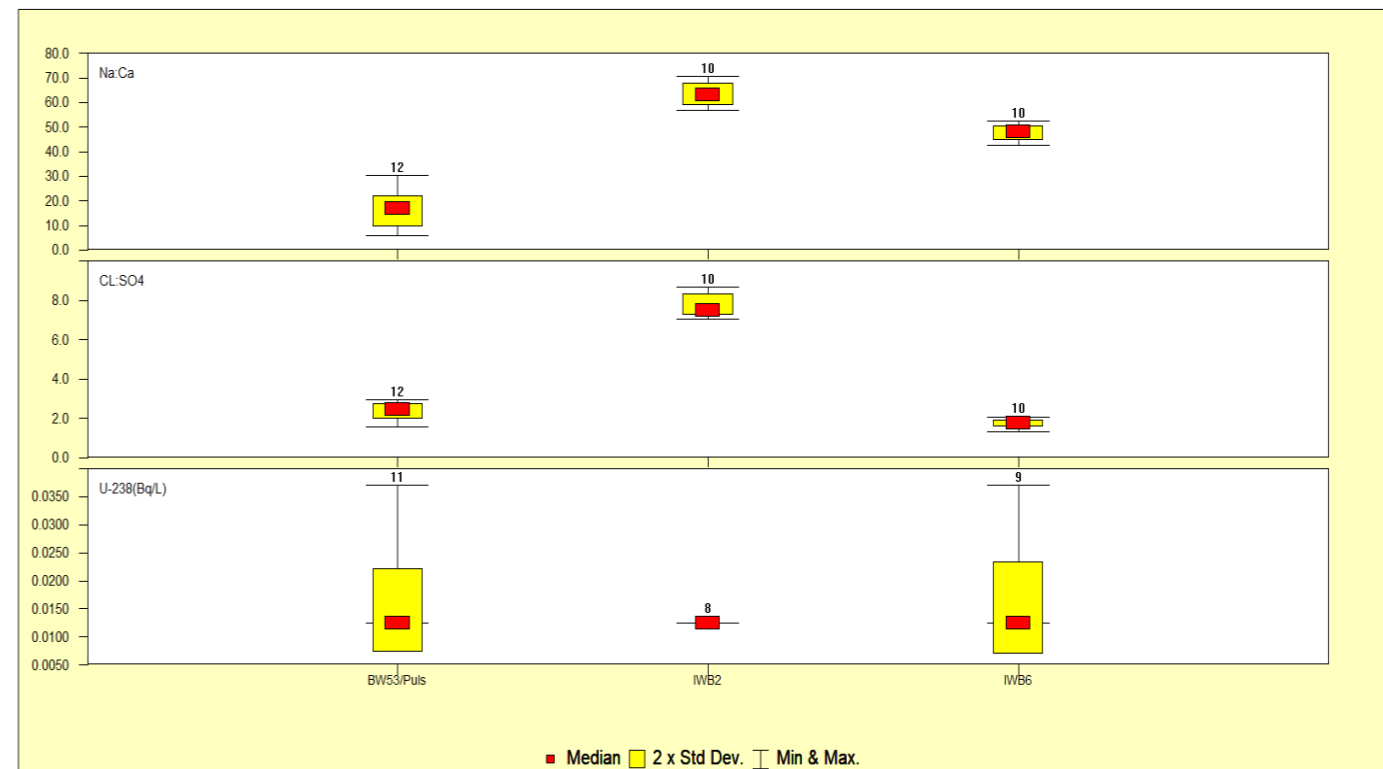

Figure 20: U-238 and ionic balance trends – bores representing background (2 of 2)

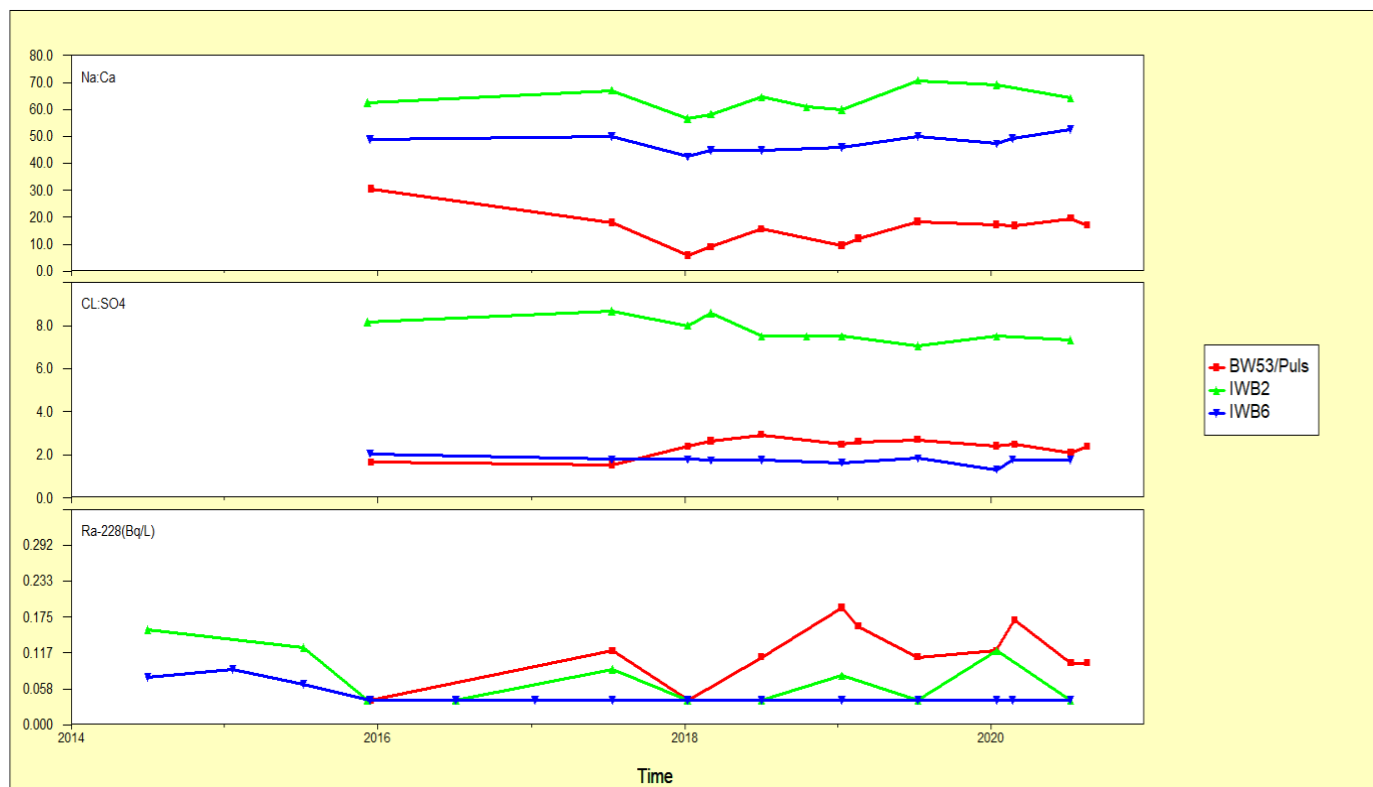

Figure 21: Ra-228 and ionic balance trends – bores representing background (1 of 2)

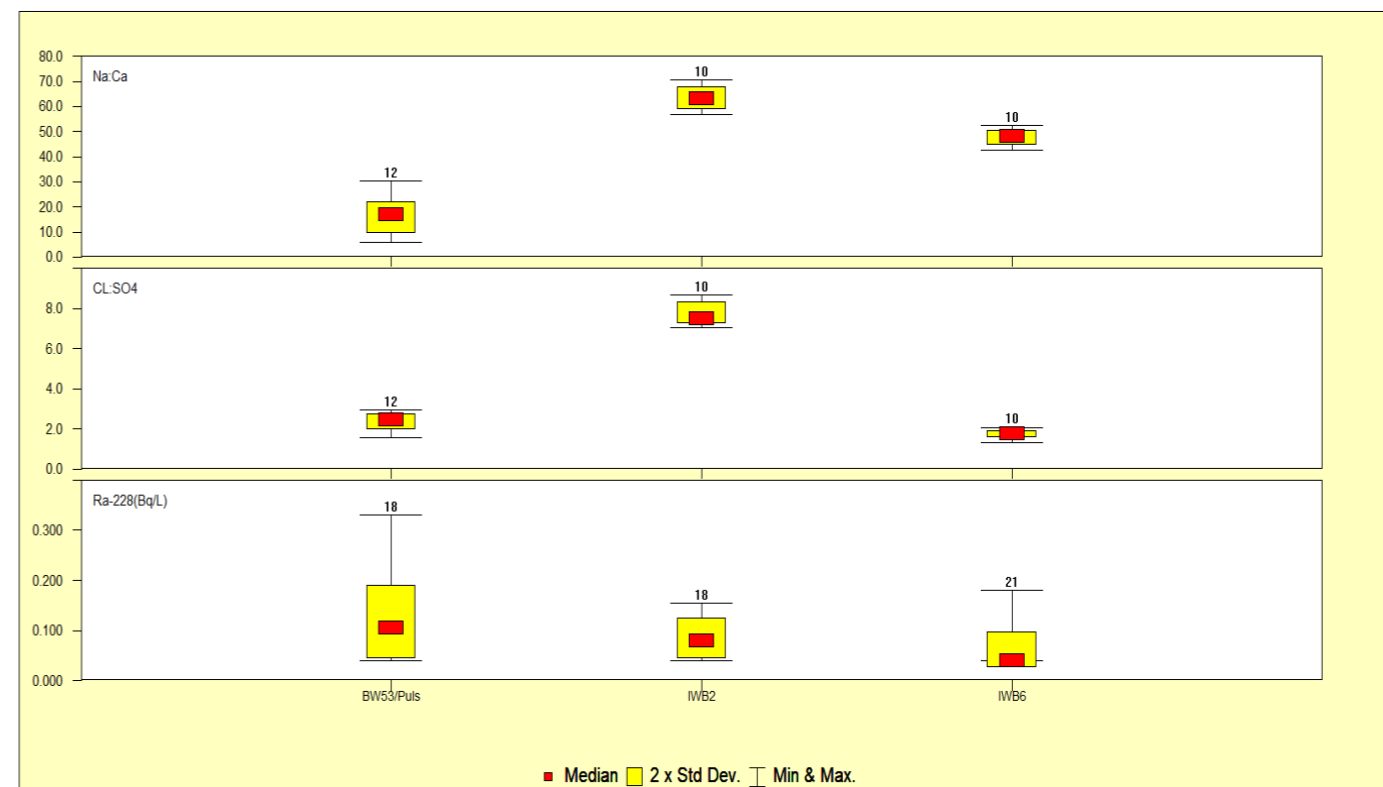

Figure 22: Ra-228 and ionic balance trends – bores representing background (2 of 2)

4.1.3.3 Other analytes

In accordance with Section 7.6.7 of the EMP, biannual groundwater samples obtained from the monitoring locations are subjected to in-field and laboratory analysis for a suite of target parameters.

Analyte concentrations above trigger limits that coincided with ionic balance ratio triggers are presented in Table 5 & Table 6 and Figure 23. In summary:

- analysis recorded an elevated selenium result at GW04 during August and October as part of the follow up sampling required due to an ionic balance trigger that occurred during July's scheduled sampling;
- sufficient data is available to determine background concentrations for GW04, which is determined as the 75th percentile value based on the mean and standard deviation of the available data. For GW04, the 75th percentile (background) value is higher than the standard SEPP WoV objectives and therefore applies as the upper trigger (background value); and
- all results are consistent with historical values and do not indicate seepage from Pit 23.

Table 5: Groundwater quality exceedances vs ionic balance ratios, H2 2020

Bore ID	Date	Se (mg/L)	Cl:SO4		Na:Ca	
			Ratio	% Red.	Ratio	% Red.
Precautionary trigger		0.017	n/a	n/a	n/a	n/a
Upper trigger		0.02	n/a	n/a	n/a	n/a
GW04 Cross Gradient	9/07/2020	0.031	4.5	19%	13.1	-14%
	10/08/2020	0.029	4.7	16%	13.3	-17%
	2 sample av	0.030				
	10/08/2020	0.029	4.7	16%	13.3	-17%
	15/10/2020	0.026	4.2	25%	12.3	-8%
	2 sample av	0.028				

Table 6: Selenium groundwater trigger levels for GW04, H2 2020

GW04	Se (mg/L)	AVG	Std Dev	Background (av+2SD)	Prec Trigger (85% of b/g)	Upper Trigger	Ion. Bal. Rep. Exceedance?	2- sample AVG	Comment
28/11/2018	0.029	-	-	-	-	-	No	-	min 5 results reqd for statistical analysis
15/01/2019	0.023	0.026	0.004	0.0345	-	-	No	0.026	min 5 results reqd for statistical analysis
8/07/2019	0.025	0.026	0.003	0.0318	-	-	YES (Na:Ca)	0.024	min 5 results reqd for statistical analysis
1/08/2019	0.024	0.025	0.003	0.0305	-	-	YES (Na:Ca)	0.0245	min 5 results reqd for statistical analysis
12/09/2019	0.029	0.026	0.003	0.0317	0.0269	0.0317	YES (Na:Ca)	0.0265	Na:Ca Ratio triggered, Se equal to precautionary trigger
15/01/2020	0.022	0.025	0.003	0.0314	0.0267	0.0314	YES (Na:Ca)	0.0255	Na:Ca Ratio triggered, Se below precautionary trigger
20/02/2020	0.022	0.025	0.003	0.0309	0.0263	0.0309	No	0.0220	No ratio triggered, Se below precautionary trigger
9/07/2020	0.031	0.026	0.004	0.0327	0.0278	0.0327	YES (Cl:SO4)	0.0265	Se below precautionary trigger
10/08/2020	0.029	0.026	0.004	0.0330	0.0281	0.0330	YES (Cl:SO4)	0.0300	Se above precautionary trigger, below upper trigger
15/10/2020	0.026	0.026	0.003	0.0326	0.0277	0.0326	YES (Cl:SO4)	0.0275	Se below precautionary trigger

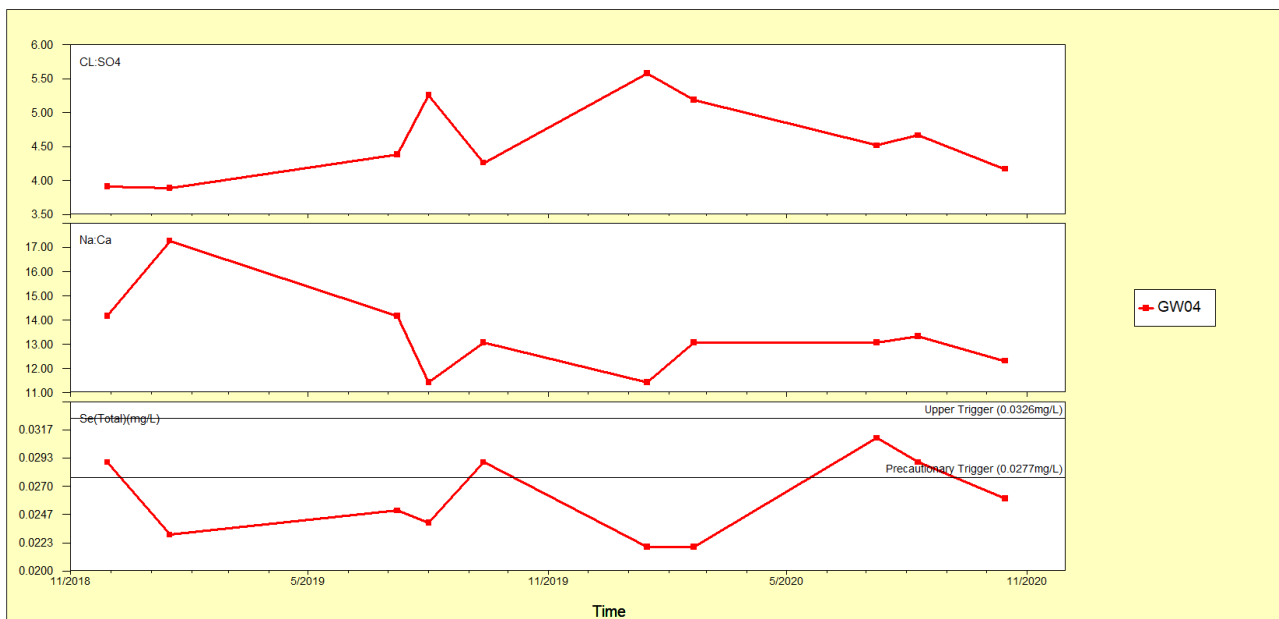

Figure 23: GW04 - Selenium as compared against ionic balance trends

All groundwater quality monitoring data (laboratory and field data) for the reporting period for all parameters monitored is provided in **Appendix B** and **Appendix C** of this report, respectively.

4.2 Surface water quality

4.2.1 Runoff-fed surface water sites

In accordance with Section 8.7.1 of the EMP, surface water samples must be obtained from nominated runoff-fed surface water monitoring points if a discharge of run-off from the disturbed area of Pit 23 and surrounds occurs.

No discharges occurred during the reporting period and subsequently no follow-up monitoring was required.

4.2.2 Groundwater-fed surface water sites

In accordance with Section 8.7.2 of the EMP, quarterly surface water samples obtained from the nominated groundwater-fed surface water monitoring points down-gradient of Pit 23 (i.e. surface water features receiving groundwater base-flow) are analysed for a suite of target parameters to identify the potential expression of Pit 23 groundwater seepage.

Results obtained for specific parameters are summarised in sections 4.2.2.1 - 4.2.2.3 below.

All surface water quality monitoring data for the reporting period and for all parameters monitored (laboratory and field results) is provided in **Appendix D** and **Appendix E** of this report.

4.2.2.1 Ionic balance ratios

Assessment of potential Pit 23 seepage and expression into surface waters is based on an analysis of Cl:SO4 and Na:Ca ratios obtained from quarterly monitoring, with a consecutive reduction in either ratio of >10% applied as potential indicator of Pit 23 seepage and expression at surface.

Ionic ratio results for nominated surface water monitoring locations in the H2 2020 reporting period are given in **Table 7**. The data presented includes results preceding the H2 2020 reporting period to show longer-term trends and to demonstrate the influence of seasonality in both the availability of

data (ability to obtain samples) and the influence that this natural variability has on surface water chemistry and hence the calculated ratios. The reliability of ratios calculated from data obtained after a long elapsed period of time (i.e. due to a lack of recent samples), and which suggest a consecutive >10% ratio exceedance, thus need to be interpreted with caution as they are more likely to reflect natural variation than any influence of Pit 23 seepage.

With reference to Table 7, no reductions of >10% exceedances in either one or both ratio's occurred during the reporting period for surface water sites along the flow path from Pit 23. A reduction of >10% exceedance was observed in Q4 2020 for the Ca:Na ratio at Shaw's Gully (DUSW22) which is an analogue/reference site and not on the Pit 23 flow path.

Table 7: Surface water monitoring - ionic ratio balance results

Sample Point	Sample Date	CL- (mg/L)	SO4 (mg/L)	CL:SO4 (ratio)	% Red.	Na (mg/L)	Ca (mg/L)	Na:Ca (ratio)	% Red.	Repeated ratio exceedance?
GROUNDWATER-FED SITES ALONG FLOW PATH FROM PIT 23										
DUSW20 (NW Drainage Line)	26/06/2017	DRY	DRY	DRY	DRY	DRY	DRY	DRY	DRY	N/A
	12/09/2017	360	61	5.9	I.D.	230	27	8.52	I.D.	
	11/10/2017	1100	150	7.33	-24%	630	71	8.87	-4%	
	15/01/2018	DRY	DRY	DRY	DRY	DRY	DRY	DRY	DRY	N/A
	19/06/2018	DRY	DRY	DRY	DRY	DRY	DRY	DRY	DRY	N/A
	17/07/2018	DRY	DRY	DRY	DRY	DRY	DRY	DRY	DRY	N/A
	8/08/2018	1100	200	5.5	25%	660	52	12.69	-43%	
	12/09/2018	DRY	DRY	DRY	DRY	DRY	DRY	DRY	DRY	N/A
	17/10/2018	DRY	DRY	DRY	DRY	DRY	DRY	DRY	DRY	N/A
	8/01/2019	DRY	DRY	DRY	DRY	DRY	DRY	DRY	DRY	N/A
	9/04/2019	DRY	DRY	DRY	DRY	DRY	DRY	DRY	DRY	N/A
	14/08/2019	82	36	2.28	59%	100	9.3	10.75	15%	
	16/09/2019	DRY	DRY	DRY	DRY	DRY	DRY	DRY	DRY	N/A
	24/10/2019	DRY	DRY	DRY	DRY	DRY	DRY	DRY	DRY	N/A
	7/01/2020	DRY	DRY	DRY	DRY	DRY	DRY	DRY	DRY	N/A
	1/04/2020	DRY	DRY	DRY	DRY	DRY	DRY	DRY	DRY	N/A
	15/06/2020	DRY	DRY	DRY	DRY	DRY	DRY	DRY	DRY	N/A
14/09/2010	42	4	10.5	-4%	46	5.5	8.4	0.2%		
8/10/2020	3700	560	6.6	-2%	2100	180	11.7	-0.1%		
DUSW24 McGlashin Swamp)	26/06/2017	530	8	66.3	I.D.	430	87	4.94	I.D.	
	12/09/2017	500	38	13.2	80%	330	62	5.32	-8%	
	11/10/2017	530	46	11.5	83%	360	69	5.22	2%	
	15/01/2018	970	68	14.3	-24%	690	42	16.43	-215%	
	19/06/2018	2100	57	36.8	-158%	1200	66	18.18	-11%	
	17/07/2018	2100	69	30.4	17%	1300	65	20	-10%	
	14/08/2018	1900	72	26.4	13%	1100	63	17.46	13%	Yes (CL:SO4)
	12/09/2018	2000	89	22.5	15%	1300	71	18.31	-5%	Yes (CL:SO4)
	17/10/2018	2700	130	20.8	8%	1500	92	16.3	11%	
	1/11/2018	3100	130	23.8	-15%	1800	100	18	-10%	

Sample Point	Sample Date	CL- (mg/L)	SO4 (mg/L)	CL:SO4 (ratio)	% Red.	Na (mg/L)	Ca (mg/L)	Na:Ca (ratio)	% Red.	Repeated ratio exceedance?
	8/01/2019	DRY	DRY	DRY	DRY	DRY	DRY	DRY	DRY	N/A
	9/04/2019	DRY	DRY	DRY	DRY	DRY	DRY	DRY	DRY	N/A
	14/08/2019	3300	820	4.02	81%	1900	270	7.04	57%	
	16/09/2019	4700	960	4.9	76%	2600	330	7.88	52%	Yes (Both)
	24/10/2019	DRY	DRY	DRY	DRY	DRY	DRY	DRY	DRY	N/A
	7/01/2020	DRY	DRY	DRY	DRY	DRY	DRY	DRY	DRY	N/A
	1/04/2020	DRY	DRY	DRY	DRY	DRY	DRY	DRY	DRY	N/A
	15/06/2020	DRY	DRY	DRY	DRY	DRY	DRY	DRY	DRY	N/A
	17/09/2020	4800	900	5.3	-0.3%	2800	340	8.2	-0.2%	
	13/10/2020	5500	1200	4.6	-0.1%	3000	360	8.3	-0.2%	
DUSW5B (White Lake)	26/06/2017	100000	8300	12	I.D.	53000	1700	31.176	I.D.	
	11/09/2017	3200	390	8.2	32%	1800	130	13.846	56%	
	11/10/2017	44000	5200	8.5	30%	23000	1400	16.429	47%	Yes (Both)
	15/01/2018	DRY	DRY	DRY	DRY	DRY	DRY	DRY	DRY	N/A
	19/06/2018	DRY	DRY	DRY	DRY	DRY	DRY	DRY	DRY	N/A
	17/07/2018	100000	7000	14.3	-69%	59000	1600	36.88	-124%	
	17/10/2018	120000	9700	12.4	13%	65000	2000	32.5	12%	
	1/11/2018	170000	9400	18.1	-27%	100000	1200	83.33	-126%	
	8/01/2019	DRY	DRY	DRY	DRY	DRY	DRY	DRY	DRY	N/A
	9/04/2019	DRY	DRY	DRY	DRY	DRY	DRY	DRY	DRY	N/A
	14/08/2019	DRY	DRY	DRY	DRY	DRY	DRY	DRY	DRY	N/A
	16/09/2019	DRY	DRY	DRY	DRY	DRY	DRY	DRY	DRY	N/A
	24/10/2019	DRY	DRY	DRY	DRY	DRY	DRY	DRY	DRY	N/A
	7/01/2020	DRY	DRY	DRY	DRY	DRY	DRY	DRY	DRY	N/A
	1/04/2020	DRY	DRY	DRY	DRY	DRY	DRY	DRY	DRY	N/A
	15/06/2020	DRY	DRY	DRY	DRY	DRY	DRY	DRY	DRY	N/A
15/07/2020	DRY	DRY	DRY	DRY	DRY	DRY	DRY	DRY	N/A	
17/09/2020	86000	6800	12.6	0.3%	56000	1700	32.9	1%		
13/10/2020	94000	7500	12.5	0.1%	52000	1700	30.6	0.1%		
GROUNDWATER-FED ANALOGUE / REFERENCE SITES (NOT ON PIT 23 FLOW PATH)										
DUSW22 (Shaw's Gully)	26/06/2017	DNS	DNS	DNS	DNS	DNS	DNS	DNS	DNS	N/A
	23/08/2017	190	35	5.4	I.D.	110	14	7.86	I.D.	
	11/10/2017	1700	180	9.4	-74%	840	91	9.23	-17%	
	15/01/2018	470	17	27.6	-193%	240	27	8.89	4%	
	19/06/2018	3600	410	8.8	68%	1800	160	11.25	-27%	
	17/07/2018	3200	330	9.7	-10%	1700	140	12.14	-8%	
	17/10/2018	2800	280	10	-3%	1400	120	11.67	4%	
	8/01/2019	DRY	DRY	DRY	DRY	DRY	DRY	DRY	DRY	N/A
	9/04/2019	DRY	DRY	DRY	DRY	DRY	DRY	DRY	DRY	N/A

Sample Point	Sample Date	CL- (mg/L)	SO4 (mg/L)	CL:SO4 (ratio)	% Red.	Na (mg/L)	Ca (mg/L)	Na:Ca (ratio)	% Red.	Repeated ratio exceedance?
	2/07/2019	2100	340	6.18	38%	1400	120	11.67	0%	
	1/08/2019	970	160	6.06	39%	550	44	12.5	-8%	Yes (Cl:SO4)
	24/10/2019	740	140	5.29	14%	410	34	12.06	-3%	Yes (Cl:SO4)
	7/01/2020	DRY	DRY	DRY	DRY	DRY	DRY	DRY	DRY	N/A
	1/04/2020	DRY	DRY	DRY	DRY	DRY	DRY	DRY	DRY	N/A
	15/06/2020	3200	360	8.9	-68%	1700	150	11.3	6%	
	15/07/2020	3000	290	10.3	-16%	1600	140	11.4	-1%	
	6/10/2020	2300	230	10.0	3%	1100	120	9.2	20%	
DUSW14 (Costello's Creek)	26/06/2017	DRY	DRY	DRY	DRY	DRY	DRY	DRY	DRY	N/A
	13/09/2017	190	34	5.59	I.D.	130	13	10	I.D.	
	11/10/2017	1400	260	5.38	4%	850	49	17.35	-73%	
	15/01/2018	DRY	DRY	DRY	DRY	DRY	DRY	DRY	DRY	N/A
	19/06/2018	1800	310	5.81	-8%	1100	67	16.42	5%	
	17/07/2018	1800	330	5.45	6%	1200	58	20.69	-26%	
	17/10/2018	1600	280	5.71	-5%	1000	50	20	3%	
	8/01/2019	2400	350	6.86	-20%	1400	50	28	-40%	
	9/04/2019	2200	240	9.17	-34%	1300	49	26.53	5%	
	2/07/2019	2200	360	6.11	33%	1300	74	17.57	34%	
	1/08/2019	1900	340	5.59	39%	1200	44	27.27	-3%	Yes (Cl:SO4)
	24/10/2019	1800	290	6.21	-2%	1200	46	26.09	-48%	
	7/01/2020	DRY	DRY	DRY	DRY	DRY	DRY	DRY	DRY	N/A
	1/04/2020	2200	240	9.2	-0.5%	1300	45	28.9	-0.1%	
	15/07/2020	2100	220	9.5	-0.04%	1400	74	18.9	0.4%	
6/10/2020	1400	240	5.8	0.4%	900	54	16.7	0.1%		

NOTES

- Calculated ratios in green represent values that increase following an initial ">10%" reduction (i.e. no consecutive >10% reduction)
- Calculated ratios in red represent values above the ">10%" reduction threshold (initial identified exceedance).
- Calculated ratios in red highlight represent a confirmed ">10%" reduction in consecutive or follow-up samples
- I.D. = insufficient data to allow calculation of ionic ratio (only one data-point available)

4.2.2.2 Radionuclide concentrations

Section 7.9.1 of the EMP prescribes the locations for surface water monitoring and the monitoring frequency, as summarised in Table 8. These locations are subject to sampling and laboratory analysis for radionuclides (Thorium, Uranium, Radium-226, Radium-228 and Uranium-238).

Radionuclide monitoring results for the reporting period are presented in Figure 24 and Figure 25. The corresponding monitoring data for radionuclides in surface water is provided in **Appendix A**. Note that for concentrations reported as below the laboratory limit of reporting / limit of detection (as indicated by "<") the numerical value is treated as a negative concentration to enable graphical representation in order to demonstrate that sampling for that analyte was undertaken in compliance with the EMP.

The monitoring results for radionuclides in surface water obtained during the reporting period confirm nil exceedances of any precautionary or upper trigger. Further, no off-site discharges from the confines of Pit 23 or immediate area occurred.

Note that long-term data for these surface water points is available and the data presented in Figure 24 and Figure 25 represents all current data for these points.

Table 8: Monitoring program – radionuclide concentrations in surface water

Surface water monitoring locations	Frequency
DUSW14 – Costello’s Creek DUSW5B – White Lake DUSW24 – McGlashin Swamp DUSW20 – North-west drainage line DUSW22 – Southern Drainage Line	<ul style="list-style-type: none"> • Quarterly; or • During or following an off-site discharge event (creek and drainage lines only)

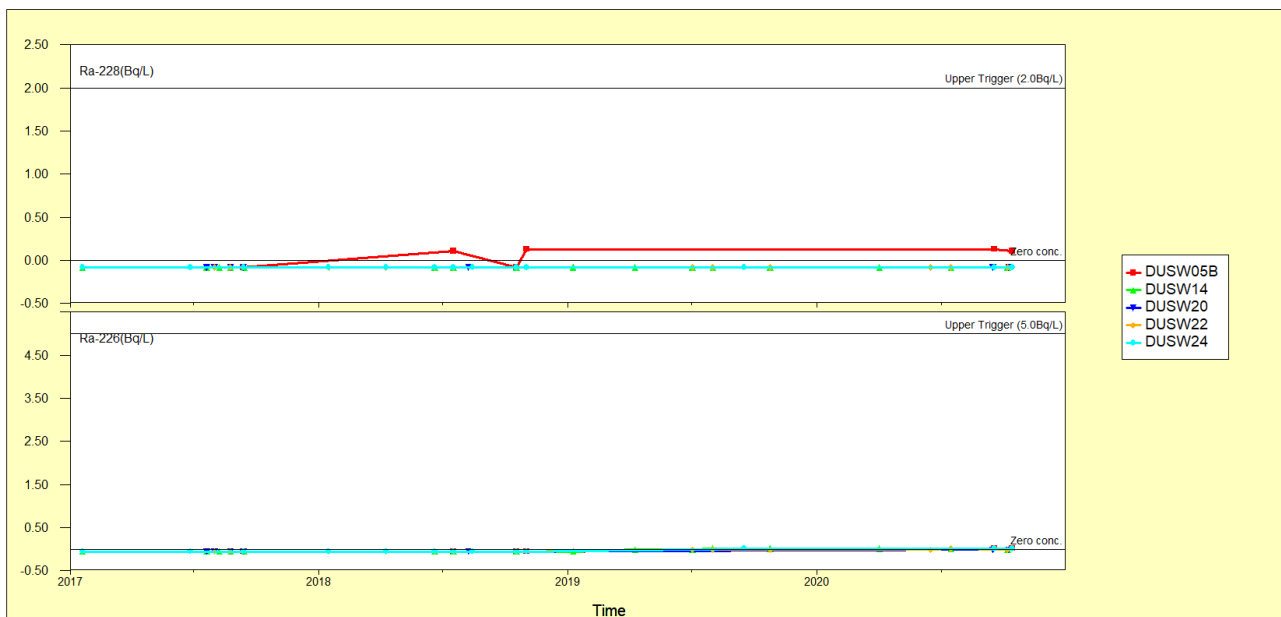

Figure 24: Ra-226 and Ra-228 in surface water

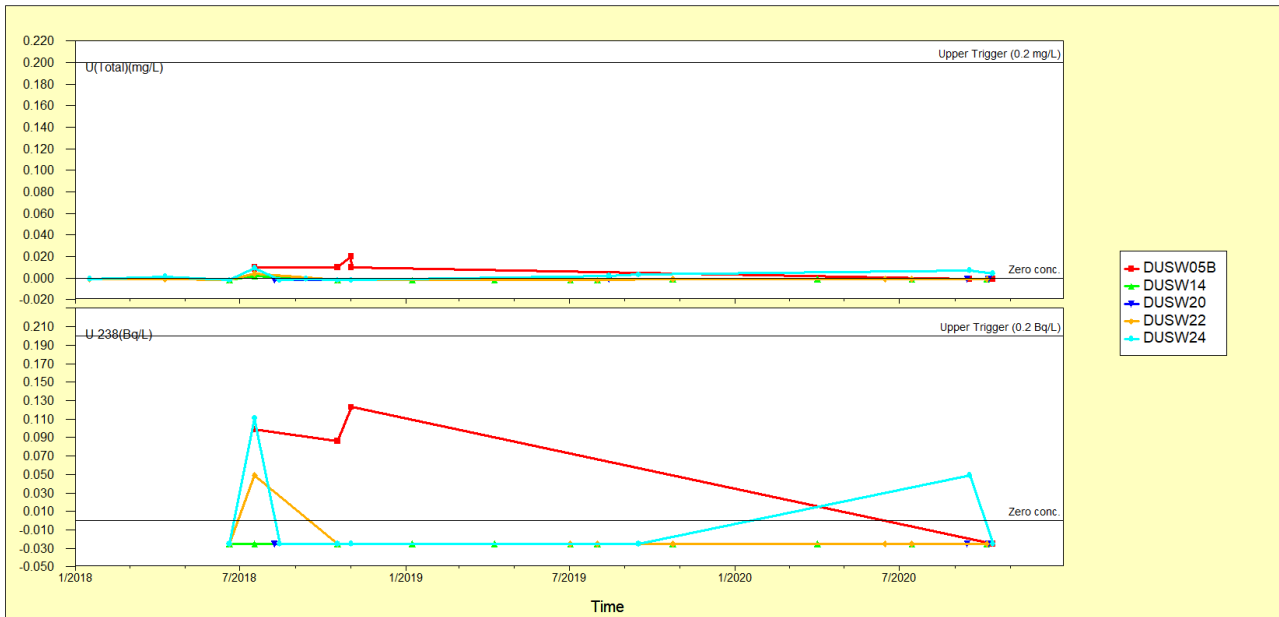

Figure 25: Uranium and U-238 in surface water

4.2.2.3 Other analytes

In accordance with Section 8.7.2 of the EMP, quarterly samples (if available) obtained from the monitoring locations are subjected to in-field and laboratory analysis for a suite of target parameters.

As discussed in Sections 4.2.1 and 4.2.2.1 there have been no runoff or discharges from site throughout the reporting period and no instances where ionic balance ratios were triggered at surface water monitoring locations along the flow path of Pit 23 that may be influenced from groundwater discharge.

4.3 Noise

In accordance with Section 10.1.4 of the endorsed EMP, noise level measurements will be undertaken in the unlikely event that noise complaints are received.

No noise related complaints were received during the reporting period, and hence no noise levels measurements were undertaken.

4.4 PM₁₀ concentrations in air

In accordance with Sections 9.6 and 10.1.4 of the endorsed EMP, the concentration of PM₁₀ dust in air at the Lyon's and Chadwick's residences is measured using high volume ('hi-vol') air samplers on a one-in-six day monitoring cycle. The location of these hi-vol air samplers relative to Pit 23 are shown in Figure 27.

12-month rolling results for PM₁₀ compared to daily rainfall are shown in Figure 26. Results adhere to the expected year-on-year pattern of lower airborne PM₁₀ concentrations in winter months.

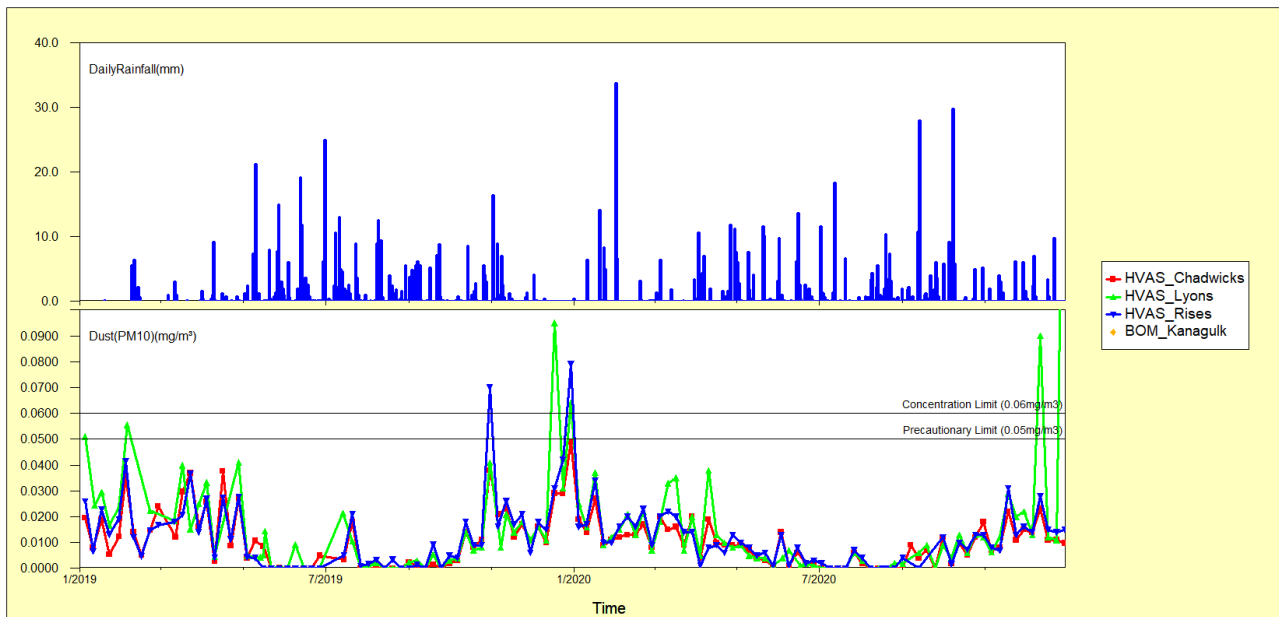

Figure 26: PM₁₀ dust concentrations at neighbouring residences vs. daily rainfall

Two results above the PM₁₀ concentration limit (0.06 mg/m³) were recorded at the Lyons residence in H2 2020, on the 12th and 30th December 2012.

Per Section 9.6 of the Pit 23 EMP, where an exceedance of a precautionary or upper concentration limit has occurred Iluka is to determine whether the elevated result is associated with Pit 23. This determination requires comparison between measured PM₁₀ concentrations at the Chadwick’s and Lyon’s residences per the method outlined in Table 24 of the EMP, shown below:

Table 9: Elevated PM10 association with Pit 23 matrix

Location	If measured concentration is		Associated?
Chadwick’s	> Trigger Level	> Lyon’s	Yes
Chadwick’s	> Trigger Level	< Lyon’s	No
Lyon’s	> Trigger Level	> Chadwick’s	No
Lyon’s	> Trigger Level	< Chadwick’s	Yes

Assessment of the two H2 2020 concentration exceedances observed at the Lyon’s residence based on the above protocol is given in Table 10 below.

Based on this assessment, and with reference to field monitoring notes and weather data from the Kanagulk BOM station (Station # 079097) on these dates, neither exceedance was associated with Pit 23.



In both instances the measured PM₁₀ concentrations at the Chadwick’s residence, which is sited upwind of the Lyon’s property and closer to the Pit 23 facility, were lower than those measured at Lyon’s residence and below the precautionary and upper concentration limits at the same point in time. This is supported by field monitoring records and wind data which indicate dust sources unrelated to Pit 23 use and development.

Table 10: PM₁₀ exceedance assessment, H2 2020

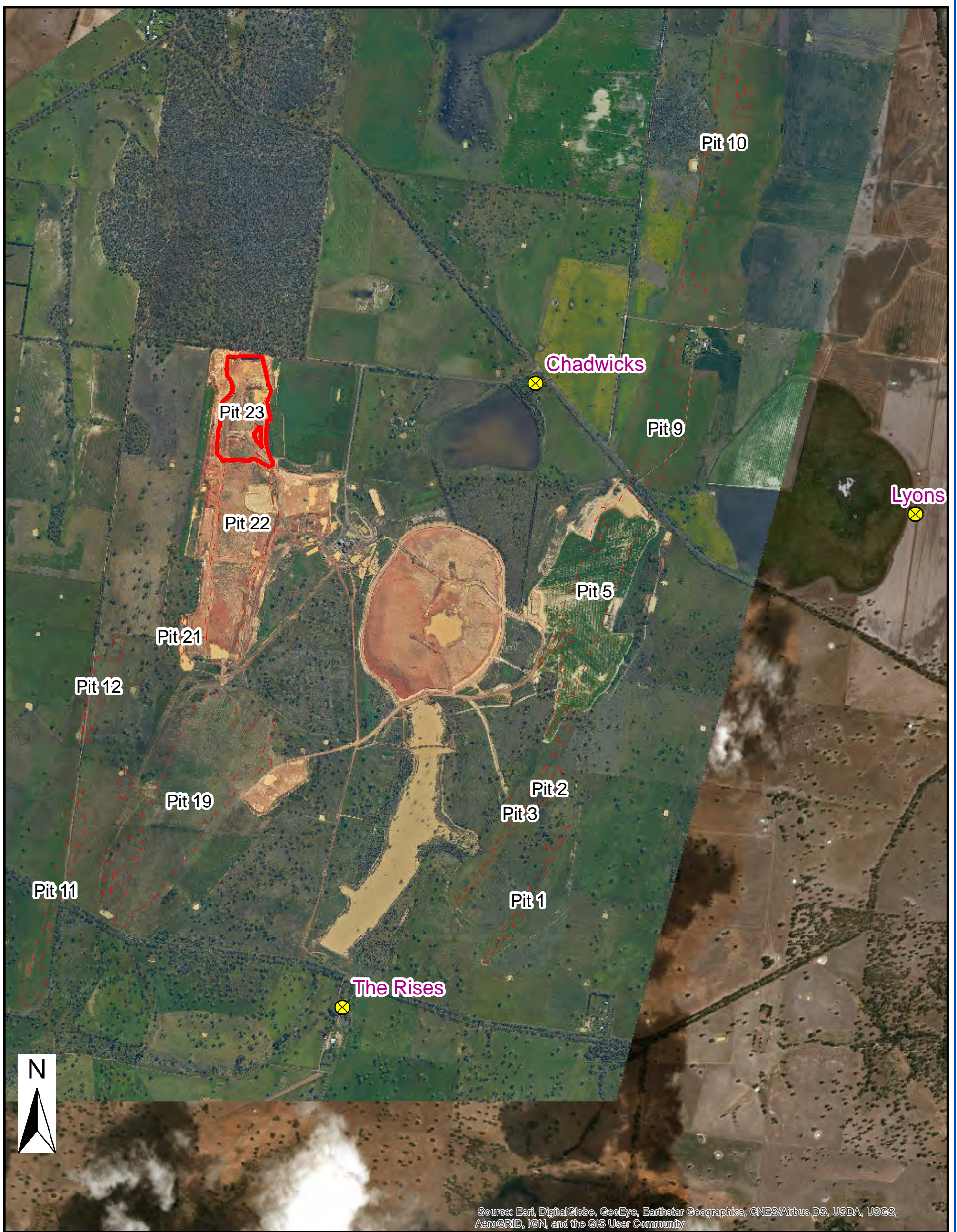
Date	Measured Concentration (mg/m ³)			Associated?	Comment
	Lyon's	Chadwick's	Rises		
12/12/20	0.09	0.023	0.028	No	BOM station indicates winds prevailing from the NE during the monitoring event (Pit 23 is sited to the W of Lyon's residence).
30/12/20	0.22	0.01	0.015	No	Sheep activity and third-party harvesting in vicinity of hi-volume air sampler unit during monitoring event. BOM station indicates winds prevailing from the S/SE during the monitoring event (Pit 23 is sited to W of Lyon's residence).



Legend

-  PM10 monitoring
-  Pit 23 crest
-  Pit Crests

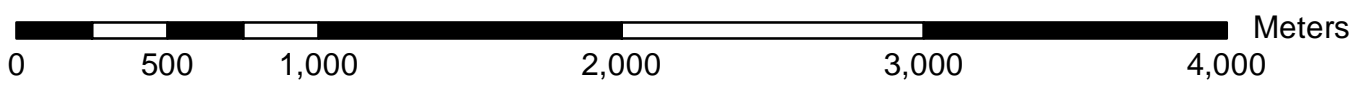

AIR QUALITY MONITORING LOCATIONS (PM10 - Hi Vols)



4.5 Radiation monitoring – other

It is a requirement of the Iluka Radiation Management Licence 300042022 that works relating to the minerals sands by-product disposal into Pit 23 are conducted in accordance with a Radiation Management Plan (RMP) and a Radioactive Waste Management Plan (RWMP), including the monitoring programs under those plans, to ensure that radiation doses are below the prescribed limit.

Radiation monitoring relevant to this performance report includes:

- Radon concentrations in air;
- Gross alpha activity concentration of airborne dust; and
- Radionuclide concentrations in groundwater and surface water.

Results for radon concentrations in air and gross alpha activity concentration of airborne dust are detailed below. Results for radionuclides in groundwater and surface water are detailed in Sections 4.1.3.2 and 4.2.2.2, respectively.

4.5.1 Radon concentrations in air

Monitoring of radon concentrations in air is undertaken at four locations within and immediately adjacent to Pit 23 and at two residences east of Pit 23 (Chadwick's) and south of Pit 23 (Rises). Radon monitoring is undertaken using Landauer "Radtrak2" radon/thoron track etch detectors and the newer RapiDOS High Sensitivity ("RapiDOS HS") radon detectors (Figure 28).

The RapiDOS HS detectors were implemented in Q4 2018 for side-by-side comparison with the existing Radtrak2 detectors, with initial results from the RapiDOS HS detectors indicating that airborne radon levels are significantly lower than those indicated by the less sensitive Radtrak2 detectors, and therefore provide a more accurate measure of actual airborne radon levels in the vicinity of Pit 23 and at local residences. This side-by-side comparison will continue through 2020 to allow for meaningful statistical comparison of radon data between units over time.

No high-sensitivity thoron detectors are available and thoron monitoring will continue using the Radtrak2 detectors.

Radon and Thoron monitoring results for the reporting period are presented in Table 11 and Table 12, and also in Figure 29 and Figure 30.

All measured radon and thoron levels in the H2 2020 reporting period were well below the reportable levels irrespective of the detectors used.



Figure 28: Radon and thoron detectors

Table 11: Radon concentrations within Pit 23 for H2 2020

Location	Radon concentration in air (Bq/m ³)				Rapidos High Sensitivity (Bq/m ³)				
	Reportable level	Jan 20 - Mar 20	Apr 20 - Jun 20	Jul 20 - Sep 20	Oct 20 - Dec 20	Jan 20 - Mar 20	Apr 20 - Jun 20	Jul 20 - Sep 20	Oct 20 - Dec 20
Pit 23 East	100	16 ± 16	<15	<15	23 ± 16	<4	<3	<8	16 ± 8
Pit 23 North	100	<15	<15	<15	15 ± 16	4 ± 3	<3	<8	<10
Pit 23 West	100	<15	<15	31 ± 14	31 ± 16	<4	<3	13 ± 7	<10
Pit 23 South	100	<20	<15	34 ± 16	<15	<3	<3	14 ± 7	<10
Chadwick's	100	<15	<15	29 ± 12	<15	6 ± 3	<3	<8	16 ± 9
Rises	100	<15	<15	<15	<15	<4	<3	15 ± 7	<10

Table 12: Thoron concentrations within Pit 23 for H2 2020

Location	Thoron concentration in air (Bq/m ³) Radtrak2 Detectors								
	Reportable level	Jan19 To Apr19	Apr19 To Jul19	Jul19 To Sep19	Oct19 To Dec19	Jan20 To Mar20	Apr20 To Jun20	Jul20 To Sep20	Oct20 To Dec20
Pit 23 East	1000	67 ± 32	34 ± 20	58 ± 26	100 ± 36	<20	<20	<30	<40
Pit 23 North	1000	42 ± 28	<30	<30	<40	23 ± 12	<20	<30	<40
Pit 23 West	1000	119 ± 32	68 ± 22	66 ± 26	83 ± 40	58 ± 16	<20	<30	87 ± 36
Pit 23 South	1000	-	138 ± 30	115 ± 30	133 ± 38	81 ± 18	<20	<30	101 ± 36
Chadwick's	1000	<30	<30	<30	<40	<20	<20	<30	<40
Rises	1000	36 ± 28	<30	<30	<40	<20	<20	<30	<40

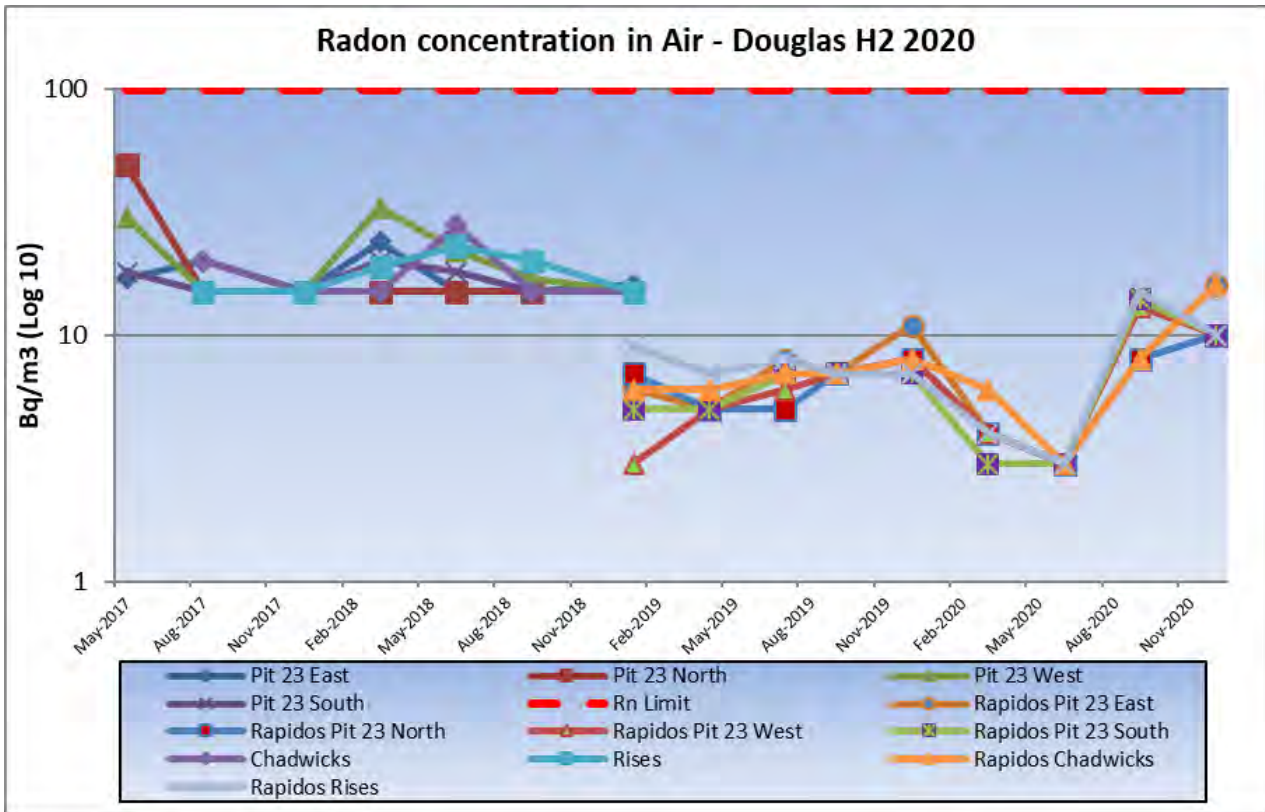

Figure 29: Radon concentration in air, H2 2020

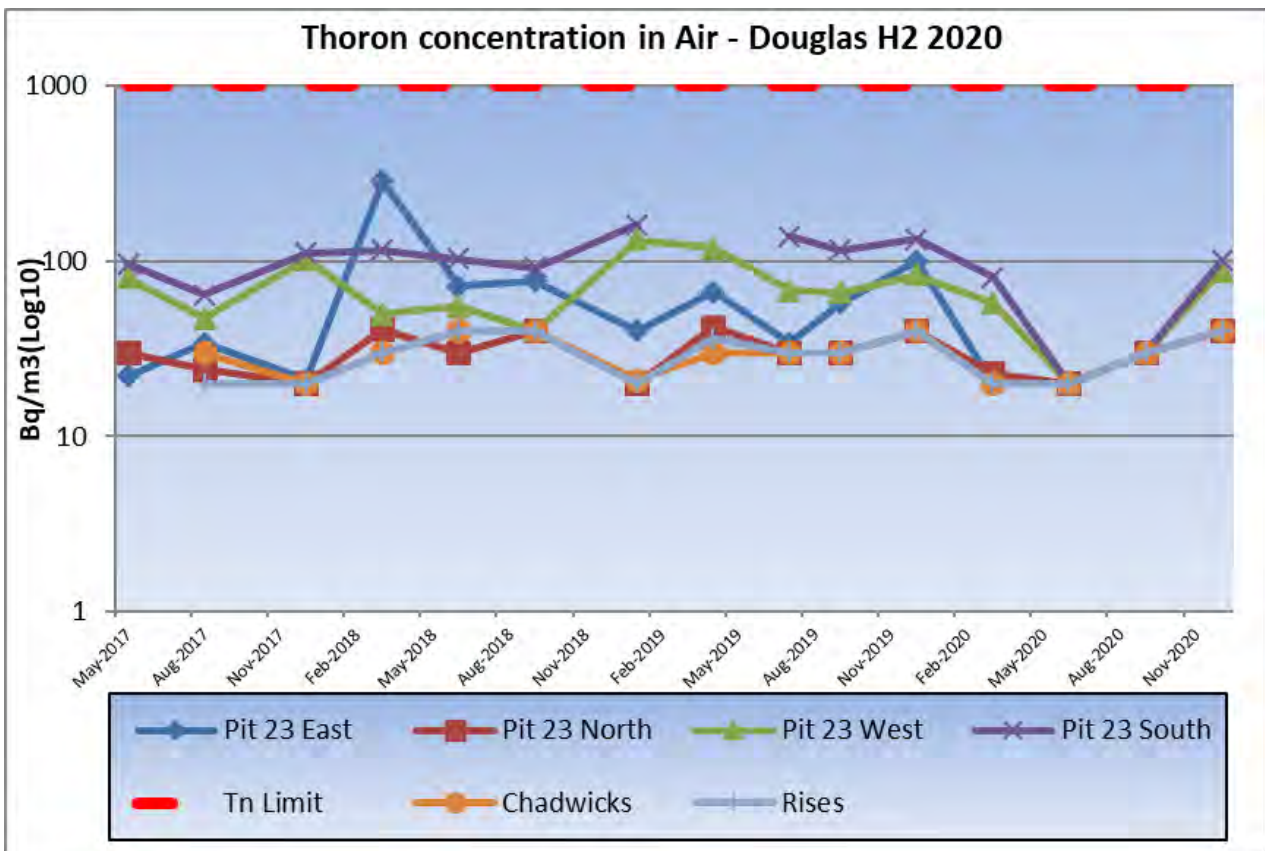

Figure 30: Thoron concentration in air, H2 2020

4.5.2 Gross alpha concentrations in airborne dust

As noted in Section 4.4, sampling for airborne particulates in PM₁₀ dust is conducted using high volume (hi-vol) air samplers located at the Chadwick’s, Lyons and Rises residences (see Figure 27).

On a quarterly basis hi-vol units are run for a continuous 96 hour period for purposes of monitoring gross alpha concentration in air, which represents a total air sample volume of approximately 6,000 m³. The filters are weighed to determine the total dust loading in mg/m³ and then analysed for gross alpha activity expressed as millibecquerels/m³ (mBq/m³).

The results for the monitoring period are in line with historical values and are shown in Table 13 and Figure 31.

Table 13: Gross Alpha radiation in PM₁₀ dust

Location	Run Date	Sample / Filter No.	Air Volume (m ³)	Activity Conc (mBq/m ³)
Chadwick’s	07/09/2020	160420GF79	6046	0.228
Lyons	13/09/2020	160420GF82	6074	0.101
Rises	01/10/2020	160420GF90	5913	0.194
Chadwick’s	19/10/2020	310820GF2	5988	0.156
Lyons	19/10/2020	160420GF100	5961	0.131
Rises	19/10/2020	310820GF1	6044	0.136

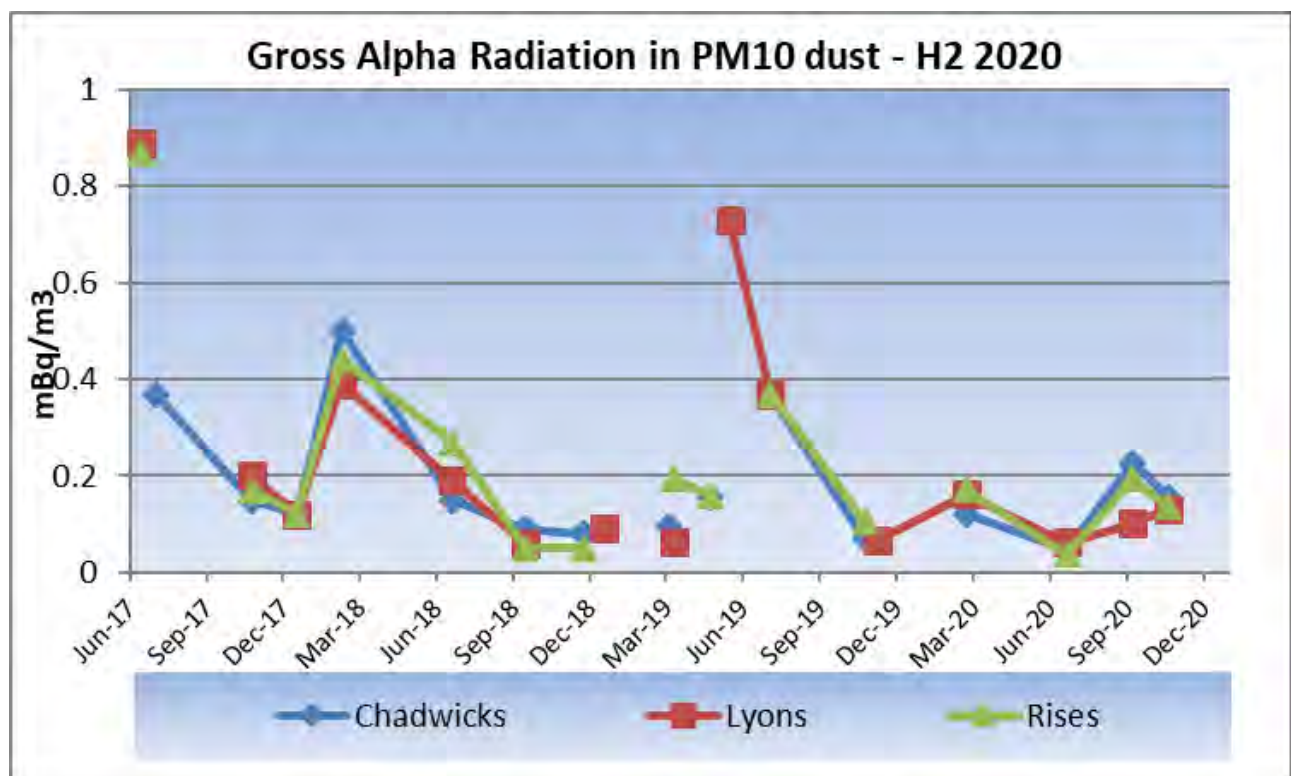

Figure 31: Gross Alpha Radiation in PM10 Dust – H2 2020

5 Management Actions

5.1 Monitoring bore audits

In accordance with Section 7.6.2 of the EMP, audits of the monitoring bore network are undertaken on monthly or bi-annually and outcomes reported annually within this EMP and Rehabilitation Performance Report.

Bore integrity (e.g. physical condition, blocked/dry or poor yield) is assessed as part of the groundwater monitoring program.

As per Section 4.1.1 of this report, all bores are in serviceable condition with the exception of BW36 which is blocked and was replaced with BW36A in October 2019.

5.2 Groundwater flow paths from Pit 23

In accordance with Section 7.9.1 of the EMP, groundwater levels measured at bores WRK300 – WRK304 inclusive, GW1 to GW7 inclusive, GW9, BW36A and BW45B are used to construct groundwater contours in the area of Pit 23 and surrounds and infer groundwater flow paths from Pit 23, with these levels and flow paths compared with the groundwater levels and flow paths predicted by the hydrogeological model.

Groundwater level contours are provided in Figure 32 (EMM 2019; EMM 2020). This compares the 2019 modelled contours per EMM (2019), and interpreted groundwater contours as at June 2020 including standing water level data for new monitoring bores installed in 2018 and 2019. From these June 2020 contours it is confirmed that:

- groundwater contours and flow-paths are consistent with the 2019 modelled contours and prior year contours; and
- groundwater flow from Pit 23 is still to the north and north-west.

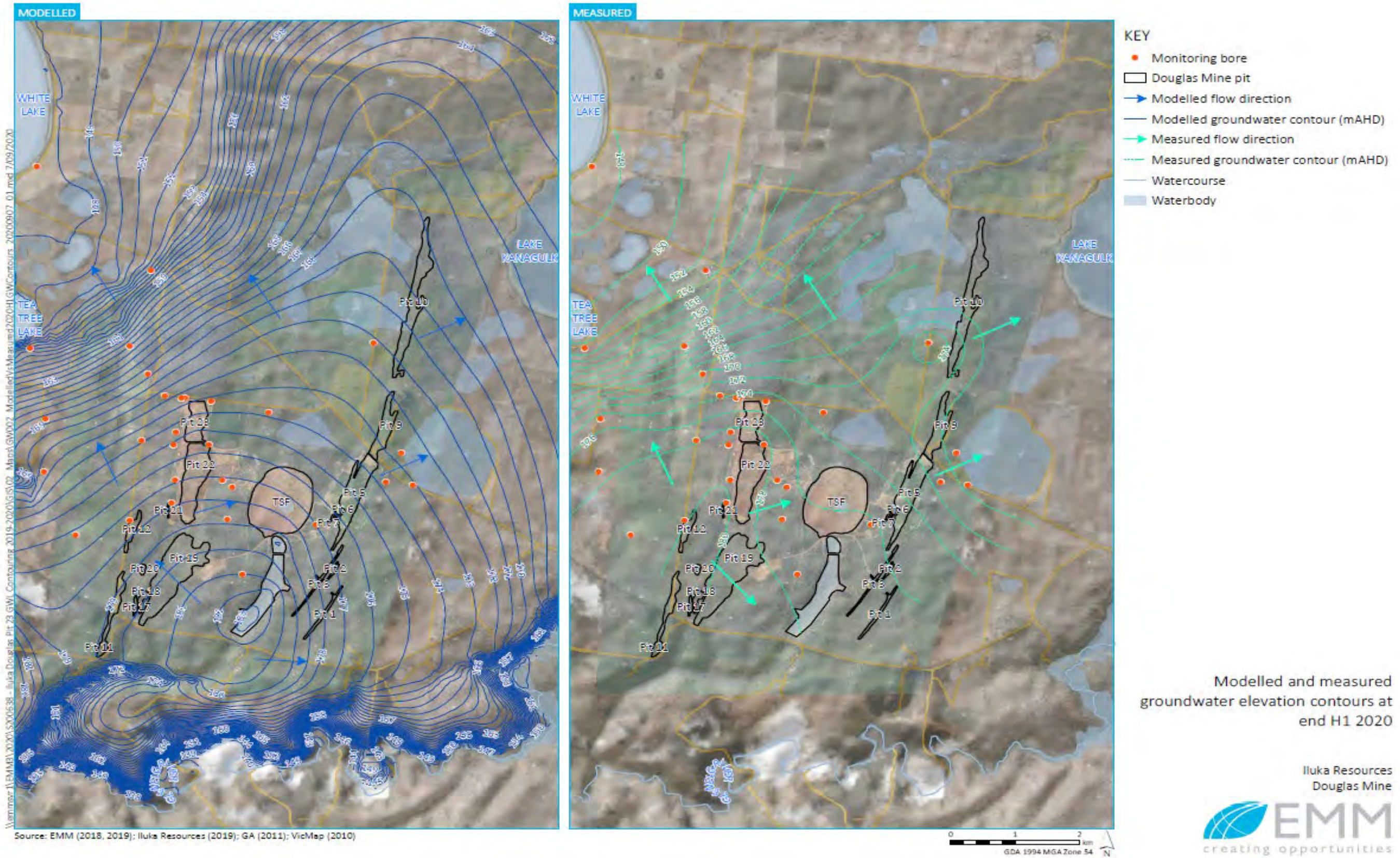

Figure 32: 2019 vs 2020 interpreted groundwater contours (EMM 2019; EMM 2020)

5.3 Groundwater model review and recalibration

Sections 7.10 and 8.7.2 of the endorsed EMP outlines the circumstances that will trigger a review and recalibration of the hydrogeological model.

An update of the Douglas Mine (inclusive Pit 23) hydrogeological model was commissioned through EMM Consulting in December 2018 in response to the potential groundwater seepage impacts identified during surface water monitoring at McGlashin's Swamp in the 2017 reporting period. This also satisfied the commitment for a review of the model within two (2) years of the Planning Permit being granted.

Whilst complimentary seepage impact investigation (EMM, 2018) determined that the observed exceedances were associated with natural phenomena and un-related to Pit 23, a review and update of the groundwater model was required in accordance with the Pit 23 EMP.

Preliminary findings of the 2019 groundwater model update were presented to the Responsible Authority and Pit 23 Technical Reference Group (TRG) by Iluka and EMM Consulting personnel at a meeting held at the HRCC Council Chambers on 23rd May 2019. The final modelling report was completed and provided to the Responsible Authority in Q3 2019.

This modelling will be used to validate existing model predictions on the groundwater flow path and groundwater flow rates from the Pit 23 facility, and to inform updates to groundwater-related content with the next iteration of the Pit 23 Environmental Management Plan (EMP, Rev 5.1).

5.4 Maximum surface level of disposed materials in Pit 23

In accordance with Section 7.9.1 of the EMP, the maximum elevation of the upper surface of materials disposed of at the end of the reporting period must be reported.

The Pit 23 void consists of an upper and lower disposal area; no wastes were disposed into Pit 23 during the H2 2020 reporting period.

Accordingly, the survey undertaken on the 8th of December 2017 confirming the upper surface of materials deposited in Pit 23 (i.e. the elevation of capped material in the upper disposal area) remains unchanged at 193 mAHD.

5.5 Non-compliances

There were no non-compliances for the H2 2020 reporting period.

5.6 Comments and complaints received

No complaints or comments were received during the H2 2020 reporting period.

5.7 H2 2020 Completed Actions

The following actions were completed during H2 2020:

- submission of the updated Pit 23 Incoming Waste Monitoring Plan (IWMP) and Environmental Management Plan (EMP) as required by the default two-year review periods stipulated within these plans. The updated EMP (Revision 5.1) included outcomes of the updated groundwater modelling completed by EMM in 2019;
- annual review of the Pit 23 Risk Analysis and Response Plan (RARP) risk register as per Section 6 of the EMP; and

- Installation of groundwater monitoring bore GW04A located between GW04 and BW36A as previously agreed with Auditor.

5.8 H1 2021 Proposed Actions

The following actions are planned for H1 2021:

- implementation of the ongoing monitoring requirements as per the EMP.

5.9 Other matters

5.9.1 Annual geotechnical audit

In accordance with Section 10.5.2 and 10.5.3 of the EMP, geotechnical audits are completed on an annual basis with the last audit completed in December 2020 (AMC Consultants, 2020).

The next audit is scheduled for November 2021.

5.9.2 Pit 23 Risk Register annual review

Per Section 6 of the EMP, the Pit 23 Risk Analysis and Response Plan (RARP) was developed by AECOM Australia Pty Ltd who recommended that the Pit 23 Risk Register (contained as Appendix A of the RARP) be reviewed annually at the time when EMP and Rehabilitation Performance Reports are developed.

Reviews of the Pit 23 RARP risk register were conducted in December 2018 and presented in the prior 2018 EMP and Rehabilitation Performance Report submitted to the Responsible Authority on 3rd June 2019.

A review of the Pit 23 RARP risk register was undertaken in November 2020 as part of the review and update of the Environmental Management Plan (EMP) and is scheduled to be reviewed in H2 2021.

6 References

ANZECC/ARMCANZ (2000) *National Water Quality Management Strategy: Australian and New Zealand Guidelines for Fresh and Marine Water Quality*. Australian and New Zealand Environment and Conservation Council and Agricultural and Resource Management Council of Australia and New Zealand, Canberra, Australian Capital Territory, October 2000.

CDM Smith (2014) Douglas Mine Site Hydrogeological Modelling. Completed on behalf of Iluka Resources, November 2014

CDM Smith (2015) Douglas Mine – Particle Tracking of Seepage Water. Completed on behalf of Iluka Resources, February 2015

EMM (2018) Pit 23 Groundwater – Assessment of Seepage Indicator Exceedances, November 2018 (Report S180265, Rev 2 Final), issued for Iluka Resources Ltd

EMM (2019) *Groundwater Model Update and Predictive Scenario Modelling – Douglas Mine*. Prepared by EMM Consulting for Iluka Resources Ltd, September 2019.

EES (2016) *Independent Desktop Review For The Continuation Of Mineral By-Products Disposal Into Pit 23 At Iluka's Douglas Mine Site, Northwest Victoria No. 215071v2 dated April 2016*. Prepared by Environmental Earth Sciences, Melbourne, Victoria. (TRIM T18729).

AMC Consultants (2021) Douglas Mine Pit 23 Geotechnical Audit & Risk Assessment, 3rd December 2020.

7 Appendices

Appendix A: Monitoring Data (Lab) – Radiation – Surface Water

Surface water ID	Date	Thorium (mg/L)	Uranium (mg/L)	U238 (Bq/L)	Ra226 (Bq/L)	Ra228 (Bq/L)
<i>Precautionary trigger</i>		<i>n/a</i>	<i>0.17</i>	<i>0.17</i>	<i>4.3</i>	<i>1.7</i>
<i>Upper trigger</i>		<i>n/a</i>	<i>0.2</i>	<i>0.2</i>	<i>5</i>	<i>2</i>
Q3 2020						
DUSW05B	15/07/2020	<i>DRY</i>	<i>DRY</i>	<i>DRY</i>	<i>DRY</i>	<i>DRY</i>
DUSW05B	17/09/2020	<0.002	<0.001	NR	0.02	0.13
DUSW14	15/07/2020	<0.002	<0.001	<0.025	<0.01	<0.08
DUSW20	15/07/2020	<i>DRY</i>	<i>DRY</i>	<i>DRY</i>	<i>DRY</i>	<i>DRY</i>
DUSW20	14/09/2020	0.0038	<0.01	<0.025	<0.01	<0.08
DUSW22	15/07/2020	<0.002	<0.001	<0.025	<0.01	<0.08
DUSW24	15/07/2020	<i>DRY</i>	<i>DRY</i>	<i>DRY</i>	<i>DRY</i>	<i>DRY</i>
DUSW24	17/09/2020	<0.002	0.007	0.049	0.01	<0.08
Q4 2020						
DUSW05B	13/10/2020	<0.002	<0.001	<0.025	0.02	0.11
DUSW14	6/10/2020	<0.002	<0.001	<0.025	<0.01	<0.08
DUSW20	8/10/2020	<0.002	<0.001	<0.025	<0.01	<0.08
DUSW22	6/10/2020	<0.002	<0.001	<0.025	<0.01	<0.08
DUSW24	13/10/2020	<0.002	0.004	<0.025	0.01	<0.08
NR = No Result due to precipitation forming in sample						

Appendix B: Monitoring Data (Lab) – Groundwater

Variable	Unit	Sample Point	Date	Result
Alkalinity (Bicarbonate) as CaCO3	mg/L	DG_A_I_PZ_GW07	2/07/2020	76
Alkalinity (Bicarbonate) as CaCO3	mg/L	DG_A_I_PZ_GW03	2/07/2020	140
Alkalinity (Bicarbonate) as CaCO3	mg/L	DG_A_I_PZ_GW02	2/07/2020	31
Alkalinity (Bicarbonate) as CaCO3	mg/L	DG_A_I_PZ_GW08	6/07/2020	170
Alkalinity (Bicarbonate) as CaCO3	mg/L	DG_A_I_PZ_WRK302	6/07/2020	93
Alkalinity (Bicarbonate) as CaCO3	mg/L	DG_A_I_PZ_GW06	6/07/2020	200
Alkalinity (Bicarbonate) as CaCO3	mg/L	DG_A_I_PZ_BW36A	7/07/2020	260
Alkalinity (Bicarbonate) as CaCO3	mg/L	DG_A_I_PZ_GW01	7/07/2020	24
Alkalinity (Bicarbonate) as CaCO3	mg/L	DG_A_I_PZ_BW45B	7/07/2020	1
Alkalinity (Bicarbonate) as CaCO3	mg/L	DG_A_I_PZ_IWB2	8/07/2020	32
Alkalinity (Bicarbonate) as CaCO3	mg/L	DG_A_I_PZ_IWB6	8/07/2020	13
Alkalinity (Bicarbonate) as CaCO3	mg/L	DG_A_I_PZ_BW05	8/07/2020	470
Alkalinity (Bicarbonate) as CaCO3	mg/L	DG_A_I_PZ_BW28A	8/07/2020	410
Alkalinity (Bicarbonate) as CaCO3	mg/L	DG_A_I_PZ_BW53/Puls	9/07/2020	95
Alkalinity (Bicarbonate) as CaCO3	mg/L	DG_A_I_PZ_GW05	9/07/2020	43
Alkalinity (Bicarbonate) as CaCO3	mg/L	DG_A_I_PZ_GW04	9/07/2020	25
Alkalinity (Bicarbonate) as CaCO3	mg/L	DG_A_I_PZ_WRK300	13/07/2020	230
Alkalinity (Bicarbonate) as CaCO3	mg/L	DG_A_I_PZ_WRK303	13/07/2020	53
Alkalinity (Bicarbonate) as CaCO3	mg/L	DG_A_I_PZ_WRK301	13/07/2020	360
Alkalinity (Bicarbonate) as CaCO3	mg/L	DG_A_I_PZ_WRK304	14/07/2020	42
Alkalinity (Bicarbonate) as CaCO3	mg/L	DG_A_I_PZ_GW04	10/08/2020	24
Alkalinity (Bicarbonate) as CaCO3	mg/L	DG_A_I_PZ_BW28A	10/08/2020	400
Alkalinity (Bicarbonate) as CaCO3	mg/L	DG_A_I_PZ_GW02	10/08/2020	33
Alkalinity (Bicarbonate) as CaCO3	mg/L	DG_A_I_PZ_GW01	10/08/2020	24
Alkalinity (Bicarbonate) as CaCO3	mg/L	DG_A_I_PZ_BW36A	17/08/2020	260
Alkalinity (Bicarbonate) as CaCO3	mg/L	DG_A_I_PZ_BW53/Puls	17/08/2020	46
Alkalinity (Bicarbonate) as CaCO3	mg/L	DG_A_I_PZ_GW05	17/08/2020	42
Alkalinity (Bicarbonate) as CaCO3	mg/L	DG_A_I_PZ_WRK303	19/08/2020	39
Alkalinity (Bicarbonate) as CaCO3	mg/L	DG_A_I_PZ_BW45B	19/08/2020	7
Alkalinity (Bicarbonate) as CaCO3	mg/L	DG_A_I_PZ_WRK304	19/08/2020	40
Alkalinity (Bicarbonate) as CaCO3	mg/L	DG_A_I_PZ_WRK302	3/09/2020	90
Alkalinity (Bicarbonate) as CaCO3	mg/L	DG_A_I_PZ_GW04	15/10/2020	23
Alkalinity (Bicarbonate) as CaCO3	mg/L	DG_A_I_PZ_GW04A	30/11/2020	51
Alkalinity (Bicarbonate) as CaCO3	mg/L	DG_A_I_PZ_GW04A	30/12/2020	51
Alkalinity (Carbonate) as CaCO3	mg/L	DG_A_I_PZ_GW07	2/07/2020	0
Alkalinity (Carbonate) as CaCO3	mg/L	DG_A_I_PZ_GW03	2/07/2020	0
Alkalinity (Carbonate) as CaCO3	mg/L	DG_A_I_PZ_GW02	2/07/2020	0
Alkalinity (Carbonate) as CaCO3	mg/L	DG_A_I_PZ_GW08	6/07/2020	0
Alkalinity (Carbonate) as CaCO3	mg/L	DG_A_I_PZ_WRK302	6/07/2020	0
Alkalinity (Carbonate) as CaCO3	mg/L	DG_A_I_PZ_GW06	6/07/2020	0
Alkalinity (Carbonate) as CaCO3	mg/L	DG_A_I_PZ_BW36A	7/07/2020	0
Alkalinity (Carbonate) as CaCO3	mg/L	DG_A_I_PZ_GW01	7/07/2020	0

Variable	Unit	Sample Point	Date	Result
Alkalinity (Carbonate) as CaCO3	mg/L	DG_A_I_PZ_BW45B	7/07/2020	0
Alkalinity (Carbonate) as CaCO3	mg/L	DG_A_I_PZ_IWB2	8/07/2020	0
Alkalinity (Carbonate) as CaCO3	mg/L	DG_A_I_PZ_IWB6	8/07/2020	0
Alkalinity (Carbonate) as CaCO3	mg/L	DG_A_I_PZ_BW05	8/07/2020	0
Alkalinity (Carbonate) as CaCO3	mg/L	DG_A_I_PZ_BW28A	8/07/2020	0
Alkalinity (Carbonate) as CaCO3	mg/L	DG_A_I_PZ_BW53/Puls	9/07/2020	0
Alkalinity (Carbonate) as CaCO3	mg/L	DG_A_I_PZ_GW05	9/07/2020	0
Alkalinity (Carbonate) as CaCO3	mg/L	DG_A_I_PZ_GW04	9/07/2020	0
Alkalinity (Carbonate) as CaCO3	mg/L	DG_A_I_PZ_WRK300	13/07/2020	0
Alkalinity (Carbonate) as CaCO3	mg/L	DG_A_I_PZ_WRK303	13/07/2020	0
Alkalinity (Carbonate) as CaCO3	mg/L	DG_A_I_PZ_WRK301	13/07/2020	0
Alkalinity (Carbonate) as CaCO3	mg/L	DG_A_I_PZ_WRK304	14/07/2020	0
Alkalinity (Carbonate) as CaCO3	mg/L	DG_A_I_PZ_GW04	10/08/2020	0
Alkalinity (Carbonate) as CaCO3	mg/L	DG_A_I_PZ_BW28A	10/08/2020	0
Alkalinity (Carbonate) as CaCO3	mg/L	DG_A_I_PZ_GW02	10/08/2020	0
Alkalinity (Carbonate) as CaCO3	mg/L	DG_A_I_PZ_GW01	10/08/2020	0
Alkalinity (Carbonate) as CaCO3	mg/L	DG_A_I_PZ_BW36A	17/08/2020	0
Alkalinity (Carbonate) as CaCO3	mg/L	DG_A_I_PZ_BW53/Puls	17/08/2020	0
Alkalinity (Carbonate) as CaCO3	mg/L	DG_A_I_PZ_GW05	17/08/2020	0
Alkalinity (Carbonate) as CaCO3	mg/L	DG_A_I_PZ_WRK303	19/08/2020	0
Alkalinity (Carbonate) as CaCO3	mg/L	DG_A_I_PZ_BW45B	19/08/2020	0
Alkalinity (Carbonate) as CaCO3	mg/L	DG_A_I_PZ_WRK304	19/08/2020	0
Alkalinity (Carbonate) as CaCO3	mg/L	DG_A_I_PZ_WRK302	3/09/2020	0
Alkalinity (Carbonate) as CaCO3	mg/L	DG_A_I_PZ_GW04	15/10/2020	0
Alkalinity (Carbonate) as CaCO3	mg/L	DG_A_I_PZ_GW04A	30/11/2020	0
Alkalinity (Carbonate) as CaCO3	mg/L	DG_A_I_PZ_GW04A	30/12/2020	0
Alkalinity (Hydroxide) as CaCO3	mg/L	DG_A_I_PZ_GW07	2/07/2020	0
Alkalinity (Hydroxide) as CaCO3	mg/L	DG_A_I_PZ_GW03	2/07/2020	0
Alkalinity (Hydroxide) as CaCO3	mg/L	DG_A_I_PZ_GW02	2/07/2020	0
Alkalinity (Hydroxide) as CaCO3	mg/L	DG_A_I_PZ_GW08	6/07/2020	0
Alkalinity (Hydroxide) as CaCO3	mg/L	DG_A_I_PZ_WRK302	6/07/2020	0
Alkalinity (Hydroxide) as CaCO3	mg/L	DG_A_I_PZ_GW06	6/07/2020	0
Alkalinity (Hydroxide) as CaCO3	mg/L	DG_A_I_PZ_BW36A	7/07/2020	0
Alkalinity (Hydroxide) as CaCO3	mg/L	DG_A_I_PZ_GW01	7/07/2020	0
Alkalinity (Hydroxide) as CaCO3	mg/L	DG_A_I_PZ_BW45B	7/07/2020	0
Alkalinity (Hydroxide) as CaCO3	mg/L	DG_A_I_PZ_IWB2	8/07/2020	0
Alkalinity (Hydroxide) as CaCO3	mg/L	DG_A_I_PZ_IWB6	8/07/2020	0
Alkalinity (Hydroxide) as CaCO3	mg/L	DG_A_I_PZ_BW05	8/07/2020	0
Alkalinity (Hydroxide) as CaCO3	mg/L	DG_A_I_PZ_BW28A	8/07/2020	0
Alkalinity (Hydroxide) as CaCO3	mg/L	DG_A_I_PZ_BW53/Puls	9/07/2020	0
Alkalinity (Hydroxide) as CaCO3	mg/L	DG_A_I_PZ_GW05	9/07/2020	0
Alkalinity (Hydroxide) as CaCO3	mg/L	DG_A_I_PZ_GW04	9/07/2020	0
Alkalinity (Hydroxide) as CaCO3	mg/L	DG_A_I_PZ_WRK300	13/07/2020	0
Alkalinity (Hydroxide) as CaCO3	mg/L	DG_A_I_PZ_WRK303	13/07/2020	0

Variable	Unit	Sample Point	Date	Result
Alkalinity (Hydroxide) as CaCO3	mg/L	DG_A_I_PZ_WRK301	13/07/2020	0
Alkalinity (Hydroxide) as CaCO3	mg/L	DG_A_I_PZ_WRK304	14/07/2020	0
Alkalinity (Hydroxide) as CaCO3	mg/L	DG_A_I_PZ_GW04	10/08/2020	0
Alkalinity (Hydroxide) as CaCO3	mg/L	DG_A_I_PZ_BW28A	10/08/2020	0
Alkalinity (Hydroxide) as CaCO3	mg/L	DG_A_I_PZ_GW02	10/08/2020	0
Alkalinity (Hydroxide) as CaCO3	mg/L	DG_A_I_PZ_GW01	10/08/2020	0
Alkalinity (Hydroxide) as CaCO3	mg/L	DG_A_I_PZ_BW36A	17/08/2020	0
Alkalinity (Hydroxide) as CaCO3	mg/L	DG_A_I_PZ_BW53/Puls	17/08/2020	0
Alkalinity (Hydroxide) as CaCO3	mg/L	DG_A_I_PZ_GW05	17/08/2020	0
Alkalinity (Hydroxide) as CaCO3	mg/L	DG_A_I_PZ_WRK303	19/08/2020	0
Alkalinity (Hydroxide) as CaCO3	mg/L	DG_A_I_PZ_BW45B	19/08/2020	0
Alkalinity (Hydroxide) as CaCO3	mg/L	DG_A_I_PZ_WRK304	19/08/2020	0
Alkalinity (Hydroxide) as CaCO3	mg/L	DG_A_I_PZ_WRK302	3/09/2020	0
Alkalinity (Hydroxide) as CaCO3	mg/L	DG_A_I_PZ_GW04	15/10/2020	0
Alkalinity (Hydroxide) as CaCO3	mg/L	DG_A_I_PZ_GW04A	30/11/2020	0
Alkalinity (Hydroxide) as CaCO3	mg/L	DG_A_I_PZ_GW04A	30/12/2020	0
Alkalinity (Total) as CaCO3	mg/L	DG_A_I_PZ_GW07	2/07/2020	76
Alkalinity (Total) as CaCO3	mg/L	DG_A_I_PZ_GW03	2/07/2020	140
Alkalinity (Total) as CaCO3	mg/L	DG_A_I_PZ_GW02	2/07/2020	31
Alkalinity (Total) as CaCO3	mg/L	DG_A_I_PZ_GW08	6/07/2020	170
Alkalinity (Total) as CaCO3	mg/L	DG_A_I_PZ_WRK302	6/07/2020	93
Alkalinity (Total) as CaCO3	mg/L	DG_A_I_PZ_GW06	6/07/2020	200
Alkalinity (Total) as CaCO3	mg/L	DG_A_I_PZ_BW36A	7/07/2020	260
Alkalinity (Total) as CaCO3	mg/L	DG_A_I_PZ_GW01	7/07/2020	24
Alkalinity (Total) as CaCO3	mg/L	DG_A_I_PZ_BW45B	7/07/2020	1
Alkalinity (Total) as CaCO3	mg/L	DG_A_I_PZ_IWB2	8/07/2020	32
Alkalinity (Total) as CaCO3	mg/L	DG_A_I_PZ_IWB6	8/07/2020	13
Alkalinity (Total) as CaCO3	mg/L	DG_A_I_PZ_BW05	8/07/2020	470
Alkalinity (Total) as CaCO3	mg/L	DG_A_I_PZ_BW28A	8/07/2020	410
Alkalinity (Total) as CaCO3	mg/L	DG_A_I_PZ_BW53/Puls	9/07/2020	95
Alkalinity (Total) as CaCO3	mg/L	DG_A_I_PZ_GW05	9/07/2020	43
Alkalinity (Total) as CaCO3	mg/L	DG_A_I_PZ_GW04	9/07/2020	25
Alkalinity (Total) as CaCO3	mg/L	DG_A_I_PZ_WRK300	13/07/2020	230
Alkalinity (Total) as CaCO3	mg/L	DG_A_I_PZ_WRK303	13/07/2020	53
Alkalinity (Total) as CaCO3	mg/L	DG_A_I_PZ_WRK301	13/07/2020	360
Alkalinity (Total) as CaCO3	mg/L	DG_A_I_PZ_WRK304	14/07/2020	42
Alkalinity (Total) as CaCO3	mg/L	DG_A_I_PZ_GW04	10/08/2020	24
Alkalinity (Total) as CaCO3	mg/L	DG_A_I_PZ_BW28A	10/08/2020	400
Alkalinity (Total) as CaCO3	mg/L	DG_A_I_PZ_GW02	10/08/2020	33
Alkalinity (Total) as CaCO3	mg/L	DG_A_I_PZ_GW01	10/08/2020	24
Alkalinity (Total) as CaCO3	mg/L	DG_A_I_PZ_BW36A	17/08/2020	260
Alkalinity (Total) as CaCO3	mg/L	DG_A_I_PZ_BW53/Puls	17/08/2020	46
Alkalinity (Total) as CaCO3	mg/L	DG_A_I_PZ_GW05	17/08/2020	42
Alkalinity (Total) as CaCO3	mg/L	DG_A_I_PZ_WRK303	19/08/2020	39

Variable	Unit	Sample Point	Date	Result
Alkalinity (Total) as CaCO3	mg/L	DG_A_I_PZ_BW45B	19/08/2020	7
Alkalinity (Total) as CaCO3	mg/L	DG_A_I_PZ_WRK304	19/08/2020	40
Alkalinity (Total) as CaCO3	mg/L	DG_A_I_PZ_WRK302	3/09/2020	90
Alkalinity (Total) as CaCO3	mg/L	DG_A_I_PZ_GW04	15/10/2020	23
Alkalinity (Total) as CaCO3	mg/L	DG_A_I_PZ_GW04A	30/11/2020	51
Alkalinity (Total) as CaCO3	mg/L	DG_A_I_PZ_GW04A	30/12/2020	51
Aluminium (Total)	mg/L	DG_A_I_PZ_GW07	2/07/2020	0.07
Aluminium (Total)	mg/L	DG_A_I_PZ_GW03	2/07/2020	0.05
Aluminium (Total)	mg/L	DG_A_I_PZ_GW02	2/07/2020	0.05
Aluminium (Total)	mg/L	DG_A_I_PZ_GW08	6/07/2020	0.01
Aluminium (Total)	mg/L	DG_A_I_PZ_WRK302	6/07/2020	0.22
Aluminium (Total)	mg/L	DG_A_I_PZ_GW06	6/07/2020	0.26
Aluminium (Total)	mg/L	DG_A_I_PZ_BW36A	7/07/2020	0.02
Aluminium (Total)	mg/L	DG_A_I_PZ_GW01	7/07/2020	1.1
Aluminium (Total)	mg/L	DG_A_I_PZ_BW45B	7/07/2020	9.8
Aluminium (Total)	mg/L	DG_A_I_PZ_IWB2	8/07/2020	0.11
Aluminium (Total)	mg/L	DG_A_I_PZ_IWB6	8/07/2020	0.12
Aluminium (Total)	mg/L	DG_A_I_PZ_BW05	8/07/2020	0.1
Aluminium (Total)	mg/L	DG_A_I_PZ_BW28A	8/07/2020	0.01
Aluminium (Total)	mg/L	DG_A_I_PZ_BW53/Puls	9/07/2020	0.17
Aluminium (Total)	mg/L	DG_A_I_PZ_GW05	9/07/2020	0.01
Aluminium (Total)	mg/L	DG_A_I_PZ_GW04	9/07/2020	0.02
Aluminium (Total)	mg/L	DG_A_I_PZ_WRK300	13/07/2020	0.02
Aluminium (Total)	mg/L	DG_A_I_PZ_WRK303	13/07/2020	0.12
Aluminium (Total)	mg/L	DG_A_I_PZ_WRK301	13/07/2020	0.22
Aluminium (Total)	mg/L	DG_A_I_PZ_WRK304	14/07/2020	0.04
Aluminium (Total)	mg/L	DG_A_I_PZ_GW04	10/08/2020	0.02
Aluminium (Total)	mg/L	DG_A_I_PZ_BW28A	10/08/2020	0.01
Aluminium (Total)	mg/L	DG_A_I_PZ_GW02	10/08/2020	0.02
Aluminium (Total)	mg/L	DG_A_I_PZ_GW01	10/08/2020	0.97
Aluminium (Total)	mg/L	DG_A_I_PZ_BW36A	17/08/2020	0.02
Aluminium (Total)	mg/L	DG_A_I_PZ_BW53/Puls	17/08/2020	2.7
Aluminium (Total)	mg/L	DG_A_I_PZ_GW05	17/08/2020	0.01
Aluminium (Total)	mg/L	DG_A_I_PZ_WRK303	19/08/2020	0.02
Aluminium (Total)	mg/L	DG_A_I_PZ_BW45B	19/08/2020	0.43
Aluminium (Total)	mg/L	DG_A_I_PZ_WRK304	19/08/2020	0.1
Aluminium (Total)	mg/L	DG_A_I_PZ_WRK302	3/09/2020	0.25
Aluminium (Total)	mg/L	DG_A_I_PZ_GW04	15/10/2020	0.02
Aluminium (Total)	mg/L	DG_A_I_PZ_GW04A	30/11/2020	0.01
Aluminium (Total)	mg/L	DG_A_I_PZ_GW04A	30/12/2020	0.01
Ammonia Nitrogen	mg/L	DG_A_I_PZ_GW07	2/07/2020	0.46
Ammonia Nitrogen	mg/L	DG_A_I_PZ_GW03	2/07/2020	0.02
Ammonia Nitrogen	mg/L	DG_A_I_PZ_GW02	2/07/2020	0.02
Ammonia Nitrogen	mg/L	DG_A_I_PZ_GW08	6/07/2020	0.02

Variable	Unit	Sample Point	Date	Result
Ammonia Nitrogen	mg/L	DG_A_I_PZ_WRK302	6/07/2020	0.02
Ammonia Nitrogen	mg/L	DG_A_I_PZ_GW06	6/07/2020	0.02
Ammonia Nitrogen	mg/L	DG_A_I_PZ_BW36A	7/07/2020	0.054
Ammonia Nitrogen	mg/L	DG_A_I_PZ_GW01	7/07/2020	0.02
Ammonia Nitrogen	mg/L	DG_A_I_PZ_BW45B	7/07/2020	0.02
Ammonia Nitrogen	mg/L	DG_A_I_PZ_IWB2	8/07/2020	0.004
Ammonia Nitrogen	mg/L	DG_A_I_PZ_IWB6	8/07/2020	0.013
Ammonia Nitrogen	mg/L	DG_A_I_PZ_BW05	8/07/2020	0.02
Ammonia Nitrogen	mg/L	DG_A_I_PZ_BW28A	8/07/2020	0.02
Ammonia Nitrogen	mg/L	DG_A_I_PZ_BW53/Puls	9/07/2020	6.9
Ammonia Nitrogen	mg/L	DG_A_I_PZ_GW05	9/07/2020	0.02
Ammonia Nitrogen	mg/L	DG_A_I_PZ_GW04	9/07/2020	0.02
Ammonia Nitrogen	mg/L	DG_A_I_PZ_WRK300	13/07/2020	0.02
Ammonia Nitrogen	mg/L	DG_A_I_PZ_WRK303	13/07/2020	0.02
Ammonia Nitrogen	mg/L	DG_A_I_PZ_WRK301	13/07/2020	0.02
Ammonia Nitrogen	mg/L	DG_A_I_PZ_WRK304	14/07/2020	0.02
Ammonia Nitrogen	mg/L	DG_A_I_PZ_GW04	10/08/2020	0.02
Ammonia Nitrogen	mg/L	DG_A_I_PZ_BW28A	10/08/2020	0.068
Ammonia Nitrogen	mg/L	DG_A_I_PZ_GW02	10/08/2020	0.045
Ammonia Nitrogen	mg/L	DG_A_I_PZ_GW01	10/08/2020	0.02
Ammonia Nitrogen	mg/L	DG_A_I_PZ_BW36A	17/08/2020	1
Ammonia Nitrogen	mg/L	DG_A_I_PZ_BW53/Puls	17/08/2020	1.2
Ammonia Nitrogen	mg/L	DG_A_I_PZ_GW05	17/08/2020	0.11
Ammonia Nitrogen	mg/L	DG_A_I_PZ_WRK303	19/08/2020	0.082
Ammonia Nitrogen	mg/L	DG_A_I_PZ_BW45B	19/08/2020	0.041
Ammonia Nitrogen	mg/L	DG_A_I_PZ_WRK304	19/08/2020	0.02
Ammonia Nitrogen	mg/L	DG_A_I_PZ_WRK302	3/09/2020	0.02
Ammonia Nitrogen	mg/L	DG_A_I_PZ_GW04	15/10/2020	0.022
Ammonia Nitrogen	mg/L	DG_A_I_PZ_GW04A	30/11/2020	0.004
Ammonia Nitrogen	mg/L	DG_A_I_PZ_GW04A	30/12/2020	0.004
Anions (Total)	meq/L	DG_A_I_PZ_GW07	2/07/2020	180
Anions (Total)	meq/L	DG_A_I_PZ_GW03	2/07/2020	110
Anions (Total)	meq/L	DG_A_I_PZ_GW02	2/07/2020	70
Anions (Total)	meq/L	DG_A_I_PZ_GW08	6/07/2020	220
Anions (Total)	meq/L	DG_A_I_PZ_WRK302	6/07/2020	210
Anions (Total)	meq/L	DG_A_I_PZ_GW06	6/07/2020	220
Anions (Total)	meq/L	DG_A_I_PZ_BW36A	7/07/2020	65
Anions (Total)	meq/L	DG_A_I_PZ_GW01	7/07/2020	100
Anions (Total)	meq/L	DG_A_I_PZ_BW45B	7/07/2020	170
Anions (Total)	meq/L	DG_A_I_PZ_IWB2	8/07/2020	36
Anions (Total)	meq/L	DG_A_I_PZ_IWB6	8/07/2020	15
Anions (Total)	meq/L	DG_A_I_PZ_BW05	8/07/2020	250
Anions (Total)	meq/L	DG_A_I_PZ_BW28A	8/07/2020	230
Anions (Total)	meq/L	DG_A_I_PZ_BW53/Puls	9/07/2020	30

Variable	Unit	Sample Point	Date	Result
Anions (Total)	meq/L	DG_A_I_PZ_GW05	9/07/2020	90
Anions (Total)	meq/L	DG_A_I_PZ_GW04	9/07/2020	93
Anions (Total)	meq/L	DG_A_I_PZ_WRK300	13/07/2020	59
Anions (Total)	meq/L	DG_A_I_PZ_WRK303	13/07/2020	92
Anions (Total)	meq/L	DG_A_I_PZ_WRK301	13/07/2020	110
Anions (Total)	meq/L	DG_A_I_PZ_WRK304	14/07/2020	83
Anions (Total)	meq/L	DG_A_I_PZ_GW04	10/08/2020	93
Anions (Total)	meq/L	DG_A_I_PZ_BW28A	10/08/2020	230
Anions (Total)	meq/L	DG_A_I_PZ_GW02	10/08/2020	69
Anions (Total)	meq/L	DG_A_I_PZ_GW01	10/08/2020	100
Anions (Total)	meq/L	DG_A_I_PZ_BW36A	17/08/2020	70
Anions (Total)	meq/L	DG_A_I_PZ_BW53/Puls	17/08/2020	25
Anions (Total)	meq/L	DG_A_I_PZ_GW05	17/08/2020	86
Anions (Total)	meq/L	DG_A_I_PZ_WRK303	19/08/2020	94
Anions (Total)	meq/L	DG_A_I_PZ_BW45B	19/08/2020	160
Anions (Total)	meq/L	DG_A_I_PZ_WRK304	19/08/2020	84
Anions (Total)	meq/L	DG_A_I_PZ_WRK302	3/09/2020	210
Anions (Total)	meq/L	DG_A_I_PZ_GW04	15/10/2020	95
Anions (Total)	meq/L	DG_A_I_PZ_GW04A	30/11/2020	74
Anions (Total)	meq/L	DG_A_I_PZ_GW04A	30/12/2020	74
Antimony (Total)	mg/L	DG_A_I_PZ_GW07	2/07/2020	0.001
Antimony (Total)	mg/L	DG_A_I_PZ_GW03	2/07/2020	0.001
Antimony (Total)	mg/L	DG_A_I_PZ_GW02	2/07/2020	0.001
Antimony (Total)	mg/L	DG_A_I_PZ_GW08	6/07/2020	0.001
Antimony (Total)	mg/L	DG_A_I_PZ_WRK302	6/07/2020	0.001
Antimony (Total)	mg/L	DG_A_I_PZ_GW06	6/07/2020	0.001
Antimony (Total)	mg/L	DG_A_I_PZ_BW36A	7/07/2020	0.001
Antimony (Total)	mg/L	DG_A_I_PZ_GW01	7/07/2020	0.001
Antimony (Total)	mg/L	DG_A_I_PZ_BW45B	7/07/2020	0.001
Antimony (Total)	mg/L	DG_A_I_PZ_IWB2	8/07/2020	0.001
Antimony (Total)	mg/L	DG_A_I_PZ_IWB6	8/07/2020	0.001
Antimony (Total)	mg/L	DG_A_I_PZ_BW05	8/07/2020	0.001
Antimony (Total)	mg/L	DG_A_I_PZ_BW28A	8/07/2020	0.001
Antimony (Total)	mg/L	DG_A_I_PZ_BW53/Puls	9/07/2020	0.001
Antimony (Total)	mg/L	DG_A_I_PZ_GW05	9/07/2020	0.001
Antimony (Total)	mg/L	DG_A_I_PZ_GW04	9/07/2020	0.001
Antimony (Total)	mg/L	DG_A_I_PZ_WRK300	13/07/2020	0.001
Antimony (Total)	mg/L	DG_A_I_PZ_WRK303	13/07/2020	0.001
Antimony (Total)	mg/L	DG_A_I_PZ_WRK301	13/07/2020	0.001
Antimony (Total)	mg/L	DG_A_I_PZ_WRK304	14/07/2020	0.001
Antimony (Total)	mg/L	DG_A_I_PZ_GW04	10/08/2020	0.001
Antimony (Total)	mg/L	DG_A_I_PZ_BW28A	10/08/2020	0.001
Antimony (Total)	mg/L	DG_A_I_PZ_GW02	10/08/2020	0.001
Antimony (Total)	mg/L	DG_A_I_PZ_GW01	10/08/2020	0.001

Variable	Unit	Sample Point	Date	Result
Antimony (Total)	mg/L	DG_A_I_PZ_BW36A	17/08/2020	0.001
Antimony (Total)	mg/L	DG_A_I_PZ_BW53/Puls	17/08/2020	0.001
Antimony (Total)	mg/L	DG_A_I_PZ_GW05	17/08/2020	0.001
Antimony (Total)	mg/L	DG_A_I_PZ_WRK303	19/08/2020	0.001
Antimony (Total)	mg/L	DG_A_I_PZ_BW45B	19/08/2020	0.001
Antimony (Total)	mg/L	DG_A_I_PZ_WRK304	19/08/2020	0.001
Antimony (Total)	mg/L	DG_A_I_PZ_WRK302	3/09/2020	0.001
Antimony (Total)	mg/L	DG_A_I_PZ_GW04	15/10/2020	0.015
Antimony (Total)	mg/L	DG_A_I_PZ_GW04A	30/11/2020	0.001
Antimony (Total)	mg/L	DG_A_I_PZ_GW04A	30/12/2020	0.001
Arsenic (Total)	mg/L	DG_A_I_PZ_GW07	2/07/2020	0.002
Arsenic (Total)	mg/L	DG_A_I_PZ_GW03	2/07/2020	0.013
Arsenic (Total)	mg/L	DG_A_I_PZ_GW02	2/07/2020	0.001
Arsenic (Total)	mg/L	DG_A_I_PZ_GW08	6/07/2020	0.001
Arsenic (Total)	mg/L	DG_A_I_PZ_WRK302	6/07/2020	0.002
Arsenic (Total)	mg/L	DG_A_I_PZ_GW06	6/07/2020	0.005
Arsenic (Total)	mg/L	DG_A_I_PZ_BW36A	7/07/2020	0.14
Arsenic (Total)	mg/L	DG_A_I_PZ_GW01	7/07/2020	0.007
Arsenic (Total)	mg/L	DG_A_I_PZ_BW45B	7/07/2020	0.007
Arsenic (Total)	mg/L	DG_A_I_PZ_IWB2	8/07/2020	0.002
Arsenic (Total)	mg/L	DG_A_I_PZ_IWB6	8/07/2020	0.011
Arsenic (Total)	mg/L	DG_A_I_PZ_BW05	8/07/2020	0.01
Arsenic (Total)	mg/L	DG_A_I_PZ_BW28A	8/07/2020	0.65
Arsenic (Total)	mg/L	DG_A_I_PZ_BW53/Puls	9/07/2020	0.009
Arsenic (Total)	mg/L	DG_A_I_PZ_GW05	9/07/2020	0.005
Arsenic (Total)	mg/L	DG_A_I_PZ_GW04	9/07/2020	0.006
Arsenic (Total)	mg/L	DG_A_I_PZ_WRK300	13/07/2020	0.002
Arsenic (Total)	mg/L	DG_A_I_PZ_WRK303	13/07/2020	0.002
Arsenic (Total)	mg/L	DG_A_I_PZ_WRK301	13/07/2020	0.004
Arsenic (Total)	mg/L	DG_A_I_PZ_WRK304	14/07/2020	0.01
Arsenic (Total)	mg/L	DG_A_I_PZ_GW04	10/08/2020	0.007
Arsenic (Total)	mg/L	DG_A_I_PZ_BW28A	10/08/2020	0.73
Arsenic (Total)	mg/L	DG_A_I_PZ_GW02	10/08/2020	0.002
Arsenic (Total)	mg/L	DG_A_I_PZ_GW01	10/08/2020	0.009
Arsenic (Total)	mg/L	DG_A_I_PZ_BW36A	17/08/2020	0.17
Arsenic (Total)	mg/L	DG_A_I_PZ_BW53/Puls	17/08/2020	0.008
Arsenic (Total)	mg/L	DG_A_I_PZ_GW05	17/08/2020	0.004
Arsenic (Total)	mg/L	DG_A_I_PZ_WRK303	19/08/2020	0.002
Arsenic (Total)	mg/L	DG_A_I_PZ_BW45B	19/08/2020	0.007
Arsenic (Total)	mg/L	DG_A_I_PZ_WRK304	19/08/2020	0.008
Arsenic (Total)	mg/L	DG_A_I_PZ_WRK302	3/09/2020	0.004
Arsenic (Total)	mg/L	DG_A_I_PZ_GW04	15/10/2020	0.006
Arsenic (Total)	mg/L	DG_A_I_PZ_GW04A	30/11/2020	0.001
Arsenic (Total)	mg/L	DG_A_I_PZ_GW04A	30/12/2020	0.001

Variable	Unit	Sample Point	Date	Result
Barium (Total)	mg/L	DG_A_I_PZ_GW07	2/07/2020	0.025
Barium (Total)	mg/L	DG_A_I_PZ_GW03	2/07/2020	0.013
Barium (Total)	mg/L	DG_A_I_PZ_GW02	2/07/2020	0.035
Barium (Total)	mg/L	DG_A_I_PZ_GW08	6/07/2020	0.005
Barium (Total)	mg/L	DG_A_I_PZ_WRK302	6/07/2020	0.02
Barium (Total)	mg/L	DG_A_I_PZ_GW06	6/07/2020	0.02
Barium (Total)	mg/L	DG_A_I_PZ_BW36A	7/07/2020	0.43
Barium (Total)	mg/L	DG_A_I_PZ_GW01	7/07/2020	0.045
Barium (Total)	mg/L	DG_A_I_PZ_BW45B	7/07/2020	0.03
Barium (Total)	mg/L	DG_A_I_PZ_IWB2	8/07/2020	0.003
Barium (Total)	mg/L	DG_A_I_PZ_IWB6	8/07/2020	0.026
Barium (Total)	mg/L	DG_A_I_PZ_BW05	8/07/2020	0.029
Barium (Total)	mg/L	DG_A_I_PZ_BW28A	8/07/2020	0.076
Barium (Total)	mg/L	DG_A_I_PZ_BW53/Puls	9/07/2020	0.042
Barium (Total)	mg/L	DG_A_I_PZ_GW05	9/07/2020	0.018
Barium (Total)	mg/L	DG_A_I_PZ_GW04	9/07/2020	0.024
Barium (Total)	mg/L	DG_A_I_PZ_WRK300	13/07/2020	0.021
Barium (Total)	mg/L	DG_A_I_PZ_WRK303	13/07/2020	0.044
Barium (Total)	mg/L	DG_A_I_PZ_WRK301	13/07/2020	0.011
Barium (Total)	mg/L	DG_A_I_PZ_WRK304	14/07/2020	0.035
Barium (Total)	mg/L	DG_A_I_PZ_GW04	10/08/2020	0.022
Barium (Total)	mg/L	DG_A_I_PZ_BW28A	10/08/2020	0.079
Barium (Total)	mg/L	DG_A_I_PZ_GW02	10/08/2020	0.037
Barium (Total)	mg/L	DG_A_I_PZ_GW01	10/08/2020	0.045
Barium (Total)	mg/L	DG_A_I_PZ_BW36A	17/08/2020	0.45
Barium (Total)	mg/L	DG_A_I_PZ_BW53/Puls	17/08/2020	0.035
Barium (Total)	mg/L	DG_A_I_PZ_GW05	17/08/2020	0.014
Barium (Total)	mg/L	DG_A_I_PZ_WRK303	19/08/2020	0.044
Barium (Total)	mg/L	DG_A_I_PZ_BW45B	19/08/2020	0.031
Barium (Total)	mg/L	DG_A_I_PZ_WRK304	19/08/2020	0.036
Barium (Total)	mg/L	DG_A_I_PZ_WRK302	3/09/2020	0.022
Barium (Total)	mg/L	DG_A_I_PZ_GW04	15/10/2020	0.022
Barium (Total)	mg/L	DG_A_I_PZ_GW04A	30/11/2020	0.072
Barium (Total)	mg/L	DG_A_I_PZ_GW04A	30/12/2020	0.072
Beryllium (Total)	mg/L	DG_A_I_PZ_GW07	2/07/2020	0.002
Beryllium (Total)	mg/L	DG_A_I_PZ_GW03	2/07/2020	0.001
Beryllium (Total)	mg/L	DG_A_I_PZ_GW02	2/07/2020	0.001
Beryllium (Total)	mg/L	DG_A_I_PZ_GW08	6/07/2020	0.001
Beryllium (Total)	mg/L	DG_A_I_PZ_WRK302	6/07/2020	0.001
Beryllium (Total)	mg/L	DG_A_I_PZ_GW06	6/07/2020	0.001
Beryllium (Total)	mg/L	DG_A_I_PZ_BW36A	7/07/2020	0.001
Beryllium (Total)	mg/L	DG_A_I_PZ_GW01	7/07/2020	0.011
Beryllium (Total)	mg/L	DG_A_I_PZ_BW45B	7/07/2020	0.009
Beryllium (Total)	mg/L	DG_A_I_PZ_IWB2	8/07/2020	0.001

Variable	Unit	Sample Point	Date	Result
Beryllium (Total)	mg/L	DG_A_I_PZ_IWB6	8/07/2020	0.001
Beryllium (Total)	mg/L	DG_A_I_PZ_BW05	8/07/2020	0.001
Beryllium (Total)	mg/L	DG_A_I_PZ_BW28A	8/07/2020	0.001
Beryllium (Total)	mg/L	DG_A_I_PZ_BW53/Puls	9/07/2020	0.001
Beryllium (Total)	mg/L	DG_A_I_PZ_GW05	9/07/2020	0.001
Beryllium (Total)	mg/L	DG_A_I_PZ_GW04	9/07/2020	0.001
Beryllium (Total)	mg/L	DG_A_I_PZ_WRK300	13/07/2020	0.001
Beryllium (Total)	mg/L	DG_A_I_PZ_WRK303	13/07/2020	0.001
Beryllium (Total)	mg/L	DG_A_I_PZ_WRK301	13/07/2020	0.001
Beryllium (Total)	mg/L	DG_A_I_PZ_WRK304	14/07/2020	0.001
Beryllium (Total)	mg/L	DG_A_I_PZ_GW04	10/08/2020	0.001
Beryllium (Total)	mg/L	DG_A_I_PZ_BW28A	10/08/2020	0.001
Beryllium (Total)	mg/L	DG_A_I_PZ_GW02	10/08/2020	0.001
Beryllium (Total)	mg/L	DG_A_I_PZ_GW01	10/08/2020	0.01
Beryllium (Total)	mg/L	DG_A_I_PZ_BW36A	17/08/2020	0.001
Beryllium (Total)	mg/L	DG_A_I_PZ_BW53/Puls	17/08/2020	0.001
Beryllium (Total)	mg/L	DG_A_I_PZ_GW05	17/08/2020	0.001
Beryllium (Total)	mg/L	DG_A_I_PZ_WRK303	19/08/2020	0.001
Beryllium (Total)	mg/L	DG_A_I_PZ_BW45B	19/08/2020	0.007
Beryllium (Total)	mg/L	DG_A_I_PZ_WRK304	19/08/2020	0.001
Beryllium (Total)	mg/L	DG_A_I_PZ_WRK302	3/09/2020	0.001
Beryllium (Total)	mg/L	DG_A_I_PZ_GW04	15/10/2020	0.001
Beryllium (Total)	mg/L	DG_A_I_PZ_GW04A	30/11/2020	0.001
Beryllium (Total)	mg/L	DG_A_I_PZ_GW04A	30/12/2020	0.001
Boron (Total)	mg/L	DG_A_I_PZ_GW07	2/07/2020	1.6
Boron (Total)	mg/L	DG_A_I_PZ_GW03	2/07/2020	0.26
Boron (Total)	mg/L	DG_A_I_PZ_GW02	2/07/2020	0.1
Boron (Total)	mg/L	DG_A_I_PZ_GW08	6/07/2020	1.5
Boron (Total)	mg/L	DG_A_I_PZ_WRK302	6/07/2020	1.8
Boron (Total)	mg/L	DG_A_I_PZ_GW06	6/07/2020	1.7
Boron (Total)	mg/L	DG_A_I_PZ_BW36A	7/07/2020	0.07
Boron (Total)	mg/L	DG_A_I_PZ_GW01	7/07/2020	0.11
Boron (Total)	mg/L	DG_A_I_PZ_BW45B	7/07/2020	1
Boron (Total)	mg/L	DG_A_I_PZ_IWB2	8/07/2020	0.06
Boron (Total)	mg/L	DG_A_I_PZ_IWB6	8/07/2020	0.03
Boron (Total)	mg/L	DG_A_I_PZ_BW05	8/07/2020	1.4
Boron (Total)	mg/L	DG_A_I_PZ_BW28A	8/07/2020	0.91
Boron (Total)	mg/L	DG_A_I_PZ_BW53/Puls	9/07/2020	0.21
Boron (Total)	mg/L	DG_A_I_PZ_GW05	9/07/2020	1.1
Boron (Total)	mg/L	DG_A_I_PZ_GW04	9/07/2020	0.58
Boron (Total)	mg/L	DG_A_I_PZ_WRK300	13/07/2020	0.18
Boron (Total)	mg/L	DG_A_I_PZ_WRK303	13/07/2020	0.52
Boron (Total)	mg/L	DG_A_I_PZ_WRK301	13/07/2020	0.61
Boron (Total)	mg/L	DG_A_I_PZ_WRK304	14/07/2020	0.58

Variable	Unit	Sample Point	Date	Result
Boron (Total)	mg/L	DG_A_I_PZ_GW04	10/08/2020	0.56
Boron (Total)	mg/L	DG_A_I_PZ_BW28A	10/08/2020	0.87
Boron (Total)	mg/L	DG_A_I_PZ_GW02	10/08/2020	0.11
Boron (Total)	mg/L	DG_A_I_PZ_GW01	10/08/2020	0.1
Boron (Total)	mg/L	DG_A_I_PZ_BW36A	17/08/2020	0.07
Boron (Total)	mg/L	DG_A_I_PZ_BW53/Puls	17/08/2020	0.18
Boron (Total)	mg/L	DG_A_I_PZ_GW05	17/08/2020	0.9
Boron (Total)	mg/L	DG_A_I_PZ_WRK303	19/08/2020	0.56
Boron (Total)	mg/L	DG_A_I_PZ_BW45B	19/08/2020	1
Boron (Total)	mg/L	DG_A_I_PZ_WRK304	19/08/2020	0.67
Boron (Total)	mg/L	DG_A_I_PZ_WRK302	3/09/2020	1.7
Boron (Total)	mg/L	DG_A_I_PZ_GW04	15/10/2020	0.54
Boron (Total)	mg/L	DG_A_I_PZ_GW04A	30/11/2020	0.35
Boron (Total)	mg/L	DG_A_I_PZ_GW04A	30/12/2020	0.35
Cadmium (Total)	mg/L	DG_A_I_PZ_GW07	2/07/2020	0.0002
Cadmium (Total)	mg/L	DG_A_I_PZ_GW03	2/07/2020	0.0002
Cadmium (Total)	mg/L	DG_A_I_PZ_GW02	2/07/2020	0.0002
Cadmium (Total)	mg/L	DG_A_I_PZ_GW08	6/07/2020	0.0002
Cadmium (Total)	mg/L	DG_A_I_PZ_WRK302	6/07/2020	0.0002
Cadmium (Total)	mg/L	DG_A_I_PZ_GW06	6/07/2020	0.0002
Cadmium (Total)	mg/L	DG_A_I_PZ_BW36A	7/07/2020	0.0002
Cadmium (Total)	mg/L	DG_A_I_PZ_GW01	7/07/2020	0.0002
Cadmium (Total)	mg/L	DG_A_I_PZ_BW45B	7/07/2020	0.0002
Cadmium (Total)	mg/L	DG_A_I_PZ_IWB2	8/07/2020	0.0002
Cadmium (Total)	mg/L	DG_A_I_PZ_IWB6	8/07/2020	0.0002
Cadmium (Total)	mg/L	DG_A_I_PZ_BW05	8/07/2020	0.0002
Cadmium (Total)	mg/L	DG_A_I_PZ_BW28A	8/07/2020	0.0002
Cadmium (Total)	mg/L	DG_A_I_PZ_BW53/Puls	9/07/2020	0.0002
Cadmium (Total)	mg/L	DG_A_I_PZ_GW05	9/07/2020	0.0002
Cadmium (Total)	mg/L	DG_A_I_PZ_GW04	9/07/2020	0.0002
Cadmium (Total)	mg/L	DG_A_I_PZ_WRK300	13/07/2020	0.0002
Cadmium (Total)	mg/L	DG_A_I_PZ_WRK303	13/07/2020	0.0002
Cadmium (Total)	mg/L	DG_A_I_PZ_WRK301	13/07/2020	0.0002
Cadmium (Total)	mg/L	DG_A_I_PZ_WRK304	14/07/2020	0.0002
Cadmium (Total)	mg/L	DG_A_I_PZ_GW04	10/08/2020	0.0002
Cadmium (Total)	mg/L	DG_A_I_PZ_BW28A	10/08/2020	0.0002
Cadmium (Total)	mg/L	DG_A_I_PZ_GW02	10/08/2020	0.0002
Cadmium (Total)	mg/L	DG_A_I_PZ_GW01	10/08/2020	0.0002
Cadmium (Total)	mg/L	DG_A_I_PZ_BW36A	17/08/2020	0.0002
Cadmium (Total)	mg/L	DG_A_I_PZ_BW53/Puls	17/08/2020	0.0002
Cadmium (Total)	mg/L	DG_A_I_PZ_GW05	17/08/2020	0.0002
Cadmium (Total)	mg/L	DG_A_I_PZ_WRK303	19/08/2020	0.0002
Cadmium (Total)	mg/L	DG_A_I_PZ_BW45B	19/08/2020	0.0002
Cadmium (Total)	mg/L	DG_A_I_PZ_WRK304	19/08/2020	0.0002

Variable	Unit	Sample Point	Date	Result
Cadmium (Total)	mg/L	DG_A_I_PZ_WRK302	3/09/2020	0.0002
Cadmium (Total)	mg/L	DG_A_I_PZ_GW04	15/10/2020	0.0002
Cadmium (Total)	mg/L	DG_A_I_PZ_GW04A	30/11/2020	0.0002
Cadmium (Total)	mg/L	DG_A_I_PZ_GW04A	30/12/2020	0.0002
Calcium	mg/L	DG_A_I_PZ_GW07	2/07/2020	390
Calcium	mg/L	DG_A_I_PZ_GW03	2/07/2020	170
Calcium	mg/L	DG_A_I_PZ_GW02	2/07/2020	21
Calcium	mg/L	DG_A_I_PZ_GW08	6/07/2020	530
Calcium	mg/L	DG_A_I_PZ_WRK302	6/07/2020	520
Calcium	mg/L	DG_A_I_PZ_GW06	6/07/2020	590
Calcium	mg/L	DG_A_I_PZ_BW36A	7/07/2020	120
Calcium	mg/L	DG_A_I_PZ_GW01	7/07/2020	82
Calcium	mg/L	DG_A_I_PZ_BW45B	7/07/2020	330
Calcium	mg/L	DG_A_I_PZ_IWB2	8/07/2020	9.5
Calcium	mg/L	DG_A_I_PZ_IWB6	8/07/2020	5.9
Calcium	mg/L	DG_A_I_PZ_BW05	8/07/2020	260
Calcium	mg/L	DG_A_I_PZ_BW28A	8/07/2020	500
Calcium	mg/L	DG_A_I_PZ_BW53/Puls	9/07/2020	25
Calcium	mg/L	DG_A_I_PZ_GW05	9/07/2020	84
Calcium	mg/L	DG_A_I_PZ_GW04	9/07/2020	130
Calcium	mg/L	DG_A_I_PZ_WRK300	13/07/2020	140
Calcium	mg/L	DG_A_I_PZ_WRK303	13/07/2020	150
Calcium	mg/L	DG_A_I_PZ_WRK301	13/07/2020	260
Calcium	mg/L	DG_A_I_PZ_WRK304	14/07/2020	110
Calcium	mg/L	DG_A_I_PZ_GW04	10/08/2020	120
Calcium	mg/L	DG_A_I_PZ_BW28A	10/08/2020	480
Calcium	mg/L	DG_A_I_PZ_GW02	10/08/2020	19
Calcium	mg/L	DG_A_I_PZ_GW01	10/08/2020	78
Calcium	mg/L	DG_A_I_PZ_BW36A	17/08/2020	110
Calcium	mg/L	DG_A_I_PZ_BW53/Puls	17/08/2020	27
Calcium	mg/L	DG_A_I_PZ_GW05	17/08/2020	95
Calcium	mg/L	DG_A_I_PZ_WRK303	19/08/2020	120
Calcium	mg/L	DG_A_I_PZ_BW45B	19/08/2020	310
Calcium	mg/L	DG_A_I_PZ_WRK304	19/08/2020	110
Calcium	mg/L	DG_A_I_PZ_WRK302	3/09/2020	430
Calcium	mg/L	DG_A_I_PZ_GW04	15/10/2020	130
Calcium	mg/L	DG_A_I_PZ_GW04A	30/11/2020	120
Calcium	mg/L	DG_A_I_PZ_GW04A	30/12/2020	120
Cations (Total)	meq/L	DG_A_I_PZ_GW07	2/07/2020	180
Cations (Total)	meq/L	DG_A_I_PZ_GW03	2/07/2020	110
Cations (Total)	meq/L	DG_A_I_PZ_GW02	2/07/2020	65
Cations (Total)	meq/L	DG_A_I_PZ_GW08	6/07/2020	220
Cations (Total)	meq/L	DG_A_I_PZ_WRK302	6/07/2020	210
Cations (Total)	meq/L	DG_A_I_PZ_GW06	6/07/2020	220

Variable	Unit	Sample Point	Date	Result
Cations (Total)	meq/L	DG_A_I_PZ_BW36A	7/07/2020	68
Cations (Total)	meq/L	DG_A_I_PZ_GW01	7/07/2020	110
Cations (Total)	meq/L	DG_A_I_PZ_BW45B	7/07/2020	170
Cations (Total)	meq/L	DG_A_I_PZ_IWB2	8/07/2020	34
Cations (Total)	meq/L	DG_A_I_PZ_IWB6	8/07/2020	15
Cations (Total)	meq/L	DG_A_I_PZ_BW05	8/07/2020	260
Cations (Total)	meq/L	DG_A_I_PZ_BW28A	8/07/2020	220
Cations (Total)	meq/L	DG_A_I_PZ_BW53/Puls	9/07/2020	28
Cations (Total)	meq/L	DG_A_I_PZ_GW05	9/07/2020	95
Cations (Total)	meq/L	DG_A_I_PZ_GW04	9/07/2020	93
Cations (Total)	meq/L	DG_A_I_PZ_WRK300	13/07/2020	58
Cations (Total)	meq/L	DG_A_I_PZ_WRK303	13/07/2020	93
Cations (Total)	meq/L	DG_A_I_PZ_WRK301	13/07/2020	110
Cations (Total)	meq/L	DG_A_I_PZ_WRK304	14/07/2020	85
Cations (Total)	meq/L	DG_A_I_PZ_GW04	10/08/2020	88
Cations (Total)	meq/L	DG_A_I_PZ_BW28A	10/08/2020	210
Cations (Total)	meq/L	DG_A_I_PZ_GW02	10/08/2020	66
Cations (Total)	meq/L	DG_A_I_PZ_GW01	10/08/2020	100
Cations (Total)	meq/L	DG_A_I_PZ_BW36A	17/08/2020	70
Cations (Total)	meq/L	DG_A_I_PZ_BW53/Puls	17/08/2020	26
Cations (Total)	meq/L	DG_A_I_PZ_GW05	17/08/2020	87
Cations (Total)	meq/L	DG_A_I_PZ_WRK303	19/08/2020	89
Cations (Total)	meq/L	DG_A_I_PZ_BW45B	19/08/2020	150
Cations (Total)	meq/L	DG_A_I_PZ_WRK304	19/08/2020	77
Cations (Total)	meq/L	DG_A_I_PZ_WRK302	3/09/2020	200
Cations (Total)	meq/L	DG_A_I_PZ_GW04	15/10/2020	90
Cations (Total)	meq/L	DG_A_I_PZ_GW04A	30/11/2020	74
Cations (Total)	meq/L	DG_A_I_PZ_GW04A	30/12/2020	74
Chloride	mg/L	DG_A_I_PZ_GW07	2/07/2020	5600
Chloride	mg/L	DG_A_I_PZ_GW03	2/07/2020	3300
Chloride	mg/L	DG_A_I_PZ_GW02	2/07/2020	2100
Chloride	mg/L	DG_A_I_PZ_GW08	6/07/2020	6600
Chloride	mg/L	DG_A_I_PZ_WRK302	6/07/2020	6200
Chloride	mg/L	DG_A_I_PZ_GW06	6/07/2020	6400
Chloride	mg/L	DG_A_I_PZ_BW36A	7/07/2020	1900
Chloride	mg/L	DG_A_I_PZ_GW01	7/07/2020	3300
Chloride	mg/L	DG_A_I_PZ_BW45B	7/07/2020	5200
Chloride	mg/L	DG_A_I_PZ_IWB2	8/07/2020	1100
Chloride	mg/L	DG_A_I_PZ_IWB6	8/07/2020	350
Chloride	mg/L	DG_A_I_PZ_BW05	8/07/2020	7900
Chloride	mg/L	DG_A_I_PZ_BW28A	8/07/2020	7100
Chloride	mg/L	DG_A_I_PZ_BW53/Puls	9/07/2020	720
Chloride	mg/L	DG_A_I_PZ_GW05	9/07/2020	2700
Chloride	mg/L	DG_A_I_PZ_GW04	9/07/2020	2800

Variable	Unit	Sample Point	Date	Result
Chloride	mg/L	DG_A_I_PZ_WRK300	13/07/2020	1700
Chloride	mg/L	DG_A_I_PZ_WRK303	13/07/2020	2800
Chloride	mg/L	DG_A_I_PZ_WRK301	13/07/2020	3200
Chloride	mg/L	DG_A_I_PZ_WRK304	14/07/2020	2400
Chloride	mg/L	DG_A_I_PZ_GW04	10/08/2020	2800
Chloride	mg/L	DG_A_I_PZ_BW28A	10/08/2020	7100
Chloride	mg/L	DG_A_I_PZ_GW02	10/08/2020	2100
Chloride	mg/L	DG_A_I_PZ_GW01	10/08/2020	3400
Chloride	mg/L	DG_A_I_PZ_BW36A	17/08/2020	2100
Chloride	mg/L	DG_A_I_PZ_BW53/Puls	17/08/2020	650
Chloride	mg/L	DG_A_I_PZ_GW05	17/08/2020	2600
Chloride	mg/L	DG_A_I_PZ_WRK303	19/08/2020	2900
Chloride	mg/L	DG_A_I_PZ_BW45B	19/08/2020	5100
Chloride	mg/L	DG_A_I_PZ_WRK304	19/08/2020	2500
Chloride	mg/L	DG_A_I_PZ_WRK302	3/09/2020	6300
Chloride	mg/L	DG_A_I_PZ_GW04	15/10/2020	2800
Chloride	mg/L	DG_A_I_PZ_GW04A	30/11/2020	2300
Chloride	mg/L	DG_A_I_PZ_GW04A	30/12/2020	2300
Chloride:Sulfate Ratio		DG_A_I_PZ_GW07	2/07/2020	5.96
Chloride:Sulfate Ratio		DG_A_I_PZ_GW03	2/07/2020	5.79
Chloride:Sulfate Ratio		DG_A_I_PZ_GW02	2/07/2020	5
Chloride:Sulfate Ratio		DG_A_I_PZ_GW08	6/07/2020	5.08
Chloride:Sulfate Ratio		DG_A_I_PZ_WRK302	6/07/2020	4.43
Chloride:Sulfate Ratio		DG_A_I_PZ_GW06	6/07/2020	4.27
Chloride:Sulfate Ratio		DG_A_I_PZ_GW01	7/07/2020	6.6
Chloride:Sulfate Ratio		DG_A_I_PZ_BW45B	7/07/2020	5.78
Chloride:Sulfate Ratio		DG_A_I_PZ_IWB2	8/07/2020	7.33
Chloride:Sulfate Ratio		DG_A_I_PZ_IWB6	8/07/2020	1.75
Chloride:Sulfate Ratio		DG_A_I_PZ_BW05	8/07/2020	8.98
Chloride:Sulfate Ratio		DG_A_I_PZ_BW28A	8/07/2020	7.72
Chloride:Sulfate Ratio		DG_A_I_PZ_BW53/Puls	9/07/2020	2.12
Chloride:Sulfate Ratio		DG_A_I_PZ_GW05	9/07/2020	4.22
Chloride:Sulfate Ratio		DG_A_I_PZ_GW04	9/07/2020	4.52
Chloride:Sulfate Ratio		DG_A_I_PZ_WRK300	13/07/2020	5.31
Chloride:Sulfate Ratio		DG_A_I_PZ_WRK303	13/07/2020	4.83
Chloride:Sulfate Ratio		DG_A_I_PZ_WRK301	13/07/2020	5.33
Chloride:Sulfate Ratio		DG_A_I_PZ_WRK304	14/07/2020	3.69
Chloride:Sulfate Ratio		DG_A_I_PZ_GW04	10/08/2020	4.67
Chloride:Sulfate Ratio		DG_A_I_PZ_BW28A	10/08/2020	8.16
Chloride:Sulfate Ratio		DG_A_I_PZ_GW02	10/08/2020	5.68
Chloride:Sulfate Ratio		DG_A_I_PZ_GW01	10/08/2020	7.73
Chloride:Sulfate Ratio		DG_A_I_PZ_BW53/Puls	17/08/2020	2.41
Chloride:Sulfate Ratio		DG_A_I_PZ_GW05	17/08/2020	4.41
Chloride:Sulfate Ratio		DG_A_I_PZ_WRK303	19/08/2020	4.92

Variable	Unit	Sample Point	Date	Result
Chloride:Sulfate Ratio		DG_A_I_PZ_BW45B	19/08/2020	6.3
Chloride:Sulfate Ratio		DG_A_I_PZ_WRK304	19/08/2020	3.91
Chloride:Sulfate Ratio		DG_A_I_PZ_WRK302	3/09/2020	4.5
Chloride:Sulfate Ratio		DG_A_I_PZ_GW04	15/10/2020	4.18
Chromium (Total)	mg/L	DG_A_I_PZ_GW07	2/07/2020	0.009
Chromium (Total)	mg/L	DG_A_I_PZ_GW03	2/07/2020	0.002
Chromium (Total)	mg/L	DG_A_I_PZ_GW02	2/07/2020	0.002
Chromium (Total)	mg/L	DG_A_I_PZ_GW08	6/07/2020	0.001
Chromium (Total)	mg/L	DG_A_I_PZ_WRK302	6/07/2020	0.001
Chromium (Total)	mg/L	DG_A_I_PZ_GW06	6/07/2020	0.001
Chromium (Total)	mg/L	DG_A_I_PZ_BW36A	7/07/2020	0.001
Chromium (Total)	mg/L	DG_A_I_PZ_GW01	7/07/2020	0.005
Chromium (Total)	mg/L	DG_A_I_PZ_BW45B	7/07/2020	0.002
Chromium (Total)	mg/L	DG_A_I_PZ_IWB2	8/07/2020	0.001
Chromium (Total)	mg/L	DG_A_I_PZ_IWB6	8/07/2020	0.003
Chromium (Total)	mg/L	DG_A_I_PZ_BW05	8/07/2020	0.001
Chromium (Total)	mg/L	DG_A_I_PZ_BW28A	8/07/2020	0.001
Chromium (Total)	mg/L	DG_A_I_PZ_BW53/Puls	9/07/2020	0.001
Chromium (Total)	mg/L	DG_A_I_PZ_GW05	9/07/2020	0.001
Chromium (Total)	mg/L	DG_A_I_PZ_GW04	9/07/2020	0.001
Chromium (Total)	mg/L	DG_A_I_PZ_WRK300	13/07/2020	0.001
Chromium (Total)	mg/L	DG_A_I_PZ_WRK303	13/07/2020	0.001
Chromium (Total)	mg/L	DG_A_I_PZ_WRK301	13/07/2020	0.001
Chromium (Total)	mg/L	DG_A_I_PZ_WRK304	14/07/2020	0.026
Chromium (Total)	mg/L	DG_A_I_PZ_GW04	10/08/2020	0.003
Chromium (Total)	mg/L	DG_A_I_PZ_BW28A	10/08/2020	0.001
Chromium (Total)	mg/L	DG_A_I_PZ_GW02	10/08/2020	0.001
Chromium (Total)	mg/L	DG_A_I_PZ_GW01	10/08/2020	0.006
Chromium (Total)	mg/L	DG_A_I_PZ_BW36A	17/08/2020	0.001
Chromium (Total)	mg/L	DG_A_I_PZ_BW53/Puls	17/08/2020	0.003
Chromium (Total)	mg/L	DG_A_I_PZ_GW05	17/08/2020	0.002
Chromium (Total)	mg/L	DG_A_I_PZ_WRK303	19/08/2020	0.004
Chromium (Total)	mg/L	DG_A_I_PZ_BW45B	19/08/2020	0.001
Chromium (Total)	mg/L	DG_A_I_PZ_WRK304	19/08/2020	0.026
Chromium (Total)	mg/L	DG_A_I_PZ_WRK302	3/09/2020	0.001
Chromium (Total)	mg/L	DG_A_I_PZ_GW04	15/10/2020	0.003
Chromium (Total)	mg/L	DG_A_I_PZ_GW04A	30/11/2020	0.001
Chromium (Total)	mg/L	DG_A_I_PZ_GW04A	30/12/2020	0.001
Cobalt (Total)	mg/L	DG_A_I_PZ_GW07	2/07/2020	0.027
Cobalt (Total)	mg/L	DG_A_I_PZ_GW03	2/07/2020	0.005
Cobalt (Total)	mg/L	DG_A_I_PZ_GW02	2/07/2020	0.017
Cobalt (Total)	mg/L	DG_A_I_PZ_GW08	6/07/2020	0.001
Cobalt (Total)	mg/L	DG_A_I_PZ_WRK302	6/07/2020	0.027
Cobalt (Total)	mg/L	DG_A_I_PZ_GW06	6/07/2020	0.002

Variable	Unit	Sample Point	Date	Result
Cobalt (Total)	mg/L	DG_A_I_PZ_BW36A	7/07/2020	0.008
Cobalt (Total)	mg/L	DG_A_I_PZ_GW01	7/07/2020	0.059
Cobalt (Total)	mg/L	DG_A_I_PZ_BW45B	7/07/2020	0.033
Cobalt (Total)	mg/L	DG_A_I_PZ_IWB2	8/07/2020	0.002
Cobalt (Total)	mg/L	DG_A_I_PZ_IWB6	8/07/2020	0.002
Cobalt (Total)	mg/L	DG_A_I_PZ_BW05	8/07/2020	0.001
Cobalt (Total)	mg/L	DG_A_I_PZ_BW28A	8/07/2020	0.03
Cobalt (Total)	mg/L	DG_A_I_PZ_BW53/Puls	9/07/2020	0.001
Cobalt (Total)	mg/L	DG_A_I_PZ_GW05	9/07/2020	0.005
Cobalt (Total)	mg/L	DG_A_I_PZ_GW04	9/07/2020	0.013
Cobalt (Total)	mg/L	DG_A_I_PZ_WRK300	13/07/2020	0.001
Cobalt (Total)	mg/L	DG_A_I_PZ_WRK303	13/07/2020	0.001
Cobalt (Total)	mg/L	DG_A_I_PZ_WRK301	13/07/2020	0.001
Cobalt (Total)	mg/L	DG_A_I_PZ_WRK304	14/07/2020	0.001
Cobalt (Total)	mg/L	DG_A_I_PZ_GW04	10/08/2020	0.013
Cobalt (Total)	mg/L	DG_A_I_PZ_BW28A	10/08/2020	0.031
Cobalt (Total)	mg/L	DG_A_I_PZ_GW02	10/08/2020	0.018
Cobalt (Total)	mg/L	DG_A_I_PZ_GW01	10/08/2020	0.054
Cobalt (Total)	mg/L	DG_A_I_PZ_BW36A	17/08/2020	0.008
Cobalt (Total)	mg/L	DG_A_I_PZ_BW53/Puls	17/08/2020	0.001
Cobalt (Total)	mg/L	DG_A_I_PZ_GW05	17/08/2020	0.005
Cobalt (Total)	mg/L	DG_A_I_PZ_WRK303	19/08/2020	0.001
Cobalt (Total)	mg/L	DG_A_I_PZ_BW45B	19/08/2020	0.034
Cobalt (Total)	mg/L	DG_A_I_PZ_WRK304	19/08/2020	0.001
Cobalt (Total)	mg/L	DG_A_I_PZ_WRK302	3/09/2020	0.027
Cobalt (Total)	mg/L	DG_A_I_PZ_GW04	15/10/2020	0.013
Cobalt (Total)	mg/L	DG_A_I_PZ_GW04A	30/11/2020	0.004
Cobalt (Total)	mg/L	DG_A_I_PZ_GW04A	30/12/2020	0.004
Copper (Total)	mg/L	DG_A_I_PZ_GW07	2/07/2020	0.001
Copper (Total)	mg/L	DG_A_I_PZ_GW03	2/07/2020	0.003
Copper (Total)	mg/L	DG_A_I_PZ_GW02	2/07/2020	0.005
Copper (Total)	mg/L	DG_A_I_PZ_GW08	6/07/2020	0.001
Copper (Total)	mg/L	DG_A_I_PZ_WRK302	6/07/2020	0.001
Copper (Total)	mg/L	DG_A_I_PZ_GW06	6/07/2020	0.001
Copper (Total)	mg/L	DG_A_I_PZ_BW36A	7/07/2020	0.005
Copper (Total)	mg/L	DG_A_I_PZ_GW01	7/07/2020	0.012
Copper (Total)	mg/L	DG_A_I_PZ_BW45B	7/07/2020	0.044
Copper (Total)	mg/L	DG_A_I_PZ_IWB2	8/07/2020	0.001
Copper (Total)	mg/L	DG_A_I_PZ_IWB6	8/07/2020	0.001
Copper (Total)	mg/L	DG_A_I_PZ_BW05	8/07/2020	0.001
Copper (Total)	mg/L	DG_A_I_PZ_BW28A	8/07/2020	0.004
Copper (Total)	mg/L	DG_A_I_PZ_BW53/Puls	9/07/2020	0.002
Copper (Total)	mg/L	DG_A_I_PZ_GW05	9/07/2020	0.015
Copper (Total)	mg/L	DG_A_I_PZ_GW04	9/07/2020	0.009

Variable	Unit	Sample Point	Date	Result
Copper (Total)	mg/L	DG_A_I_PZ_WRK300	13/07/2020	0.012
Copper (Total)	mg/L	DG_A_I_PZ_WRK303	13/07/2020	0.013
Copper (Total)	mg/L	DG_A_I_PZ_WRK301	13/07/2020	0.006
Copper (Total)	mg/L	DG_A_I_PZ_WRK304	14/07/2020	0.004
Copper (Total)	mg/L	DG_A_I_PZ_GW04	10/08/2020	0.011
Copper (Total)	mg/L	DG_A_I_PZ_BW28A	10/08/2020	0.001
Copper (Total)	mg/L	DG_A_I_PZ_GW02	10/08/2020	0.002
Copper (Total)	mg/L	DG_A_I_PZ_GW01	10/08/2020	0.014
Copper (Total)	mg/L	DG_A_I_PZ_BW36A	17/08/2020	0.006
Copper (Total)	mg/L	DG_A_I_PZ_BW53/Puls	17/08/2020	0.003
Copper (Total)	mg/L	DG_A_I_PZ_GW05	17/08/2020	0.016
Copper (Total)	mg/L	DG_A_I_PZ_WRK303	19/08/2020	0.007
Copper (Total)	mg/L	DG_A_I_PZ_BW45B	19/08/2020	0.029
Copper (Total)	mg/L	DG_A_I_PZ_WRK304	19/08/2020	0.004
Copper (Total)	mg/L	DG_A_I_PZ_WRK302	3/09/2020	0.002
Copper (Total)	mg/L	DG_A_I_PZ_GW04	15/10/2020	0.008
Copper (Total)	mg/L	DG_A_I_PZ_GW04A	30/11/2020	0.001
Copper (Total)	mg/L	DG_A_I_PZ_GW04A	30/12/2020	0.001
Dissolved Oxygen	mg/L	DG_A_I_PZ_GW07	2/07/2020	9.3
Dissolved Oxygen	mg/L	DG_A_I_PZ_GW03	2/07/2020	0.1
Dissolved Oxygen	mg/L	DG_A_I_PZ_GW02	2/07/2020	2.3
Dissolved Oxygen	mg/L	DG_A_I_PZ_GW08	6/07/2020	5.6
Dissolved Oxygen	mg/L	DG_A_I_PZ_WRK302	6/07/2020	6.6
Dissolved Oxygen	mg/L	DG_A_I_PZ_GW06	6/07/2020	8.7
Dissolved Oxygen	mg/L	DG_A_I_PZ_BW36A	7/07/2020	0.1
Dissolved Oxygen	mg/L	DG_A_I_PZ_GW01	7/07/2020	4.6
Dissolved Oxygen	mg/L	DG_A_I_PZ_BW45B	7/07/2020	0.2
Dissolved Oxygen	mg/L	DG_A_I_PZ_IWB2	8/07/2020	0
Dissolved Oxygen	mg/L	DG_A_I_PZ_IWB6	8/07/2020	3.3
Dissolved Oxygen	mg/L	DG_A_I_PZ_BW05	8/07/2020	0
Dissolved Oxygen	mg/L	DG_A_I_PZ_BW28A	8/07/2020	0
Dissolved Oxygen	mg/L	DG_A_I_PZ_BW53/Puls	9/07/2020	0.5
Dissolved Oxygen	mg/L	DG_A_I_PZ_GW05	9/07/2020	0.5
Dissolved Oxygen	mg/L	DG_A_I_PZ_GW04	9/07/2020	6.4
Dissolved Oxygen	mg/L	DG_A_I_PZ_WRK300	13/07/2020	1
Dissolved Oxygen	mg/L	DG_A_I_PZ_WRK303	13/07/2020	7.8
Dissolved Oxygen	mg/L	DG_A_I_PZ_WRK301	13/07/2020	0.9
Dissolved Oxygen	mg/L	DG_A_I_PZ_WRK304	14/07/2020	9.6
Dissolved Oxygen	mg/L	DG_A_I_PZ_BW28A	10/08/2020	0
Dissolved Oxygen	mg/L	DG_A_I_PZ_GW02	10/08/2020	0.7
Dissolved Oxygen	mg/L	DG_A_I_PZ_GW01	10/08/2020	4.7
Dissolved Oxygen	mg/L	DG_A_I_PZ_GW04	10/08/2020	6.3
Dissolved Oxygen	mg/L	DG_A_I_PZ_BW53/Puls	17/08/2020	0.2
Dissolved Oxygen	mg/L	DG_A_I_PZ_GW05	17/08/2020	0.3

Variable	Unit	Sample Point	Date	Result
Dissolved Oxygen	mg/L	DG_A_I_PZ_BW36A	17/08/2020	0
Dissolved Oxygen	mg/L	DG_A_I_PZ_WRK303	19/08/2020	9.1
Dissolved Oxygen	mg/L	DG_A_I_PZ_WRK304	19/08/2020	9.7
Dissolved Oxygen	mg/L	DG_A_I_PZ_BW45B	19/08/2020	1
Dissolved Oxygen	mg/L	DG_A_I_PZ_GW07	20/08/2020	8
Dissolved Oxygen	mg/L	DG_A_I_PZ_GW03	20/08/2020	0.6
Dissolved Oxygen	mg/L	DG_A_I_PZ_WRK300	20/08/2020	0.3
Dissolved Oxygen	mg/L	DG_A_I_PZ_GW06	25/08/2020	7.6
Dissolved Oxygen	mg/L	DG_A_I_PZ_GW08	25/08/2020	7.4
Dissolved Oxygen	mg/L	DG_A_I_PZ_WRK302	25/08/2020	6.4
Dissolved Oxygen	mg/L	DG_A_I_PZ_WRK301	25/08/2020	1.2
Dissolved Oxygen	mg/L	DG_A_I_PZ_WRK302	3/09/2020	6.4
Dissolved Oxygen	mg/L	DG_A_I_PZ_GW03	3/09/2020	1
Dissolved Oxygen	mg/L	DG_A_I_PZ_GW02	3/09/2020	0
Dissolved Oxygen	mg/L	DG_A_I_PZ_GW07	7/09/2020	7.7
Dissolved Oxygen	mg/L	DG_A_I_PZ_GW05	7/09/2020	0.3
Dissolved Oxygen	mg/L	DG_A_I_PZ_GW04	7/09/2020	6.9
Dissolved Oxygen	mg/L	DG_A_I_PZ_BW36A	7/09/2020	1
Dissolved Oxygen	mg/L	DG_A_I_PZ_GW01	7/09/2020	4.6
Dissolved Oxygen	mg/L	DG_A_I_PZ_BW45B	7/09/2020	5
Dissolved Oxygen	mg/L	DG_A_I_PZ_GW08	8/09/2020	8
Dissolved Oxygen	mg/L	DG_A_I_PZ_GW06	8/09/2020	8.4
Dissolved Oxygen	mg/L	DG_A_I_PZ_WRK300	8/09/2020	1
Dissolved Oxygen	mg/L	DG_A_I_PZ_WRK304	9/09/2020	9.7
Dissolved Oxygen	mg/L	DG_A_I_PZ_WRK303	9/09/2020	4.7
Dissolved Oxygen	mg/L	DG_A_I_PZ_WRK301	9/09/2020	1.4
Dissolved Oxygen	mg/L	DG_A_I_PZ_GW04	15/10/2020	6.8
Dissolved Oxygen	mg/L	DG_A_I_PZ_GW03	15/10/2020	1.3
Dissolved Oxygen	mg/L	DG_A_I_PZ_GW02	15/10/2020	0.8
Dissolved Oxygen	mg/L	DG_A_I_PZ_GW07	16/10/2020	7.7
Dissolved Oxygen	mg/L	DG_A_I_PZ_GW01	16/10/2020	4.6
Dissolved Oxygen	mg/L	DG_A_I_PZ_BW45B	16/10/2020	0.3
Dissolved Oxygen	mg/L	DG_A_I_PZ_GW05	19/10/2020	0.3
Dissolved Oxygen	mg/L	DG_A_I_PZ_BW36A	19/10/2020	0
Dissolved Oxygen	mg/L	DG_A_I_PZ_WRK300	19/10/2020	2.1
Dissolved Oxygen	mg/L	DG_A_I_PZ_GW08	19/10/2020	6.8
Dissolved Oxygen	mg/L	DG_A_I_PZ_WRK302	19/10/2020	6.2
Dissolved Oxygen	mg/L	DG_A_I_PZ_GW06	19/10/2020	8.3
Dissolved Oxygen	mg/L	DG_A_I_PZ_WRK304	20/10/2020	9.8
Dissolved Oxygen	mg/L	DG_A_I_PZ_WRK303	20/10/2020	9.3
Dissolved Oxygen	mg/L	DG_A_I_PZ_WRK301	20/10/2020	1
Dissolved Oxygen	mg/L	DG_A_I_PZ_GW07	24/11/2020	7.6
Dissolved Oxygen	mg/L	DG_A_I_PZ_GW03	24/11/2020	3.9
Dissolved Oxygen	mg/L	DG_A_I_PZ_GW02	24/11/2020	0.7

Variable	Unit	Sample Point	Date	Result
Dissolved Oxygen	mg/L	DG_A_I_PZ_GW01	24/11/2020	5
Dissolved Oxygen	mg/L	DG_A_I_PZ_BW45B	24/11/2020	1
Dissolved Oxygen	mg/L	DG_A_I_PZ_GW04	25/11/2020	7
Dissolved Oxygen	mg/L	DG_A_I_PZ_GW05	25/11/2020	0.7
Dissolved Oxygen	mg/L	DG_A_I_PZ_BW36A	25/11/2020	1
Dissolved Oxygen	mg/L	DG_A_I_PZ_WRK300	25/11/2020	1.4
Dissolved Oxygen	mg/L	DG_A_I_PZ_GW08	26/11/2020	7.2
Dissolved Oxygen	mg/L	DG_A_I_PZ_WRK302	26/11/2020	6.1
Dissolved Oxygen	mg/L	DG_A_I_PZ_GW06	26/11/2020	8.3
Dissolved Oxygen	mg/L	DG_A_I_PZ_GW04A	30/11/2020	4.3
Dissolved Oxygen	mg/L	DG_A_I_PZ_WRK304	30/11/2020	10.2
Dissolved Oxygen	mg/L	DG_A_I_PZ_WRK303	30/11/2020	7
Dissolved Oxygen	mg/L	DG_A_I_PZ_WRK301	30/11/2020	1
Dissolved Oxygen	mg/L	DG_A_I_PZ_GW05	4/12/2020	0
Dissolved Oxygen	mg/L	DG_A_I_PZ_GW07	8/12/2020	7.8
Dissolved Oxygen	mg/L	DG_A_I_PZ_GW03	8/12/2020	4.8
Dissolved Oxygen	mg/L	DG_A_I_PZ_GW02	8/12/2020	0.6
Dissolved Oxygen	mg/L	DG_A_I_PZ_BW45B	9/12/2020	1.2
Dissolved Oxygen	mg/L	DG_A_I_PZ_GW01	9/12/2020	5.4
Dissolved Oxygen	mg/L	DG_A_I_PZ_GW04	9/12/2020	8
Dissolved Oxygen	mg/L	DG_A_I_PZ_BW36A	9/12/2020	0
Dissolved Oxygen	mg/L	DG_A_I_PZ_GW04A	10/12/2020	3
Dissolved Oxygen	mg/L	DG_A_I_PZ_GW08	10/12/2020	7
Dissolved Oxygen	mg/L	DG_A_I_PZ_WRK302	10/12/2020	6.8
Dissolved Oxygen	mg/L	DG_A_I_PZ_GW06	10/12/2020	6.8
Dissolved Oxygen	mg/L	DG_A_I_PZ_WRK304	14/12/2020	8
Dissolved Oxygen	mg/L	DG_A_I_PZ_WRK303	14/12/2020	8.1
Dissolved Oxygen	mg/L	DG_A_I_PZ_WRK301	14/12/2020	6.7
Dissolved Oxygen	mg/L	DG_A_I_PZ_WRK300	14/12/2020	2.5
Dissolved Oxygen Field	%	DG_A_I_PZ_GW07	2/07/2020	95
Dissolved Oxygen Field	%	DG_A_I_PZ_GW03	2/07/2020	9
Dissolved Oxygen Field	%	DG_A_I_PZ_GW02	2/07/2020	30
Dissolved Oxygen Field	%	DG_A_I_PZ_GW08	6/07/2020	59
Dissolved Oxygen Field	%	DG_A_I_PZ_WRK302	6/07/2020	74
Dissolved Oxygen Field	%	DG_A_I_PZ_GW06	6/07/2020	92
Dissolved Oxygen Field	%	DG_A_I_PZ_BW36A	7/07/2020	9
Dissolved Oxygen Field	%	DG_A_I_PZ_GW01	7/07/2020	47
Dissolved Oxygen Field	%	DG_A_I_PZ_BW45B	7/07/2020	4
Dissolved Oxygen Field	%	DG_A_I_PZ_IWB2	8/07/2020	0
Dissolved Oxygen Field	%	DG_A_I_PZ_IWB6	8/07/2020	35
Dissolved Oxygen Field	%	DG_A_I_PZ_BW05	8/07/2020	0
Dissolved Oxygen Field	%	DG_A_I_PZ_BW28A	8/07/2020	0
Dissolved Oxygen Field	%	DG_A_I_PZ_BW53/Puls	9/07/2020	4
Dissolved Oxygen Field	%	DG_A_I_PZ_GW05	9/07/2020	2

Variable	Unit	Sample Point	Date	Result
Dissolved Oxygen Field	%	DG_A_I_PZ_GW04	9/07/2020	61
Dissolved Oxygen Field	%	DG_A_I_PZ_WRK300	13/07/2020	9
Dissolved Oxygen Field	%	DG_A_I_PZ_WRK303	13/07/2020	81
Dissolved Oxygen Field	%	DG_A_I_PZ_WRK301	13/07/2020	10
Dissolved Oxygen Field	%	DG_A_I_PZ_WRK304	14/07/2020	101
Dissolved Oxygen Field	%	DG_A_I_PZ_BW28A	10/08/2020	0
Dissolved Oxygen Field	%	DG_A_I_PZ_GW02	10/08/2020	6
Dissolved Oxygen Field	%	DG_A_I_PZ_GW01	10/08/2020	45
Dissolved Oxygen Field	%	DG_A_I_PZ_GW04	10/08/2020	60
Dissolved Oxygen Field	%	DG_A_I_PZ_BW53/Puls	17/08/2020	5
Dissolved Oxygen Field	%	DG_A_I_PZ_GW05	17/08/2020	3
Dissolved Oxygen Field	%	DG_A_I_PZ_BW36A	17/08/2020	0
Dissolved Oxygen Field	%	DG_A_I_PZ_WRK303	19/08/2020	105
Dissolved Oxygen Field	%	DG_A_I_PZ_WRK304	19/08/2020	100
Dissolved Oxygen Field	%	DG_A_I_PZ_BW45B	19/08/2020	10
Dissolved Oxygen Field	%	DG_A_I_PZ_GW07	20/08/2020	94
Dissolved Oxygen Field	%	DG_A_I_PZ_GW03	20/08/2020	3
Dissolved Oxygen Field	%	DG_A_I_PZ_WRK300	20/08/2020	4
Dissolved Oxygen Field	%	DG_A_I_PZ_GW06	25/08/2020	89
Dissolved Oxygen Field	%	DG_A_I_PZ_GW08	25/08/2020	84
Dissolved Oxygen Field	%	DG_A_I_PZ_WRK302	25/08/2020	72
Dissolved Oxygen Field	%	DG_A_I_PZ_WRK301	25/08/2020	13
Dissolved Oxygen Field	%	DG_A_I_PZ_WRK302	3/09/2020	73
Dissolved Oxygen Field	%	DG_A_I_PZ_GW03	3/09/2020	7
Dissolved Oxygen Field	%	DG_A_I_PZ_GW02	3/09/2020	0
Dissolved Oxygen Field	%	DG_A_I_PZ_GW07	7/09/2020	88
Dissolved Oxygen Field	%	DG_A_I_PZ_GW05	7/09/2020	4
Dissolved Oxygen Field	%	DG_A_I_PZ_GW04	7/09/2020	78
Dissolved Oxygen Field	%	DG_A_I_PZ_BW36A	7/09/2020	0.1
Dissolved Oxygen Field	%	DG_A_I_PZ_GW01	7/09/2020	54
Dissolved Oxygen Field	%	DG_A_I_PZ_BW45B	7/09/2020	0.3
Dissolved Oxygen Field	%	DG_A_I_PZ_GW08	8/09/2020	92
Dissolved Oxygen Field	%	DG_A_I_PZ_GW06	8/09/2020	96
Dissolved Oxygen Field	%	DG_A_I_PZ_WRK300	8/09/2020	18
Dissolved Oxygen Field	%	DG_A_I_PZ_WRK304	9/09/2020	101
Dissolved Oxygen Field	%	DG_A_I_PZ_WRK303	9/09/2020	48
Dissolved Oxygen Field	%	DG_A_I_PZ_WRK301	9/09/2020	14
Dissolved Oxygen Field	%	DG_A_I_PZ_GW04	15/10/2020	76
Dissolved Oxygen Field	%	DG_A_I_PZ_GW03	15/10/2020	12
Dissolved Oxygen Field	%	DG_A_I_PZ_GW02	15/10/2020	10
Dissolved Oxygen Field	%	DG_A_I_PZ_GW07	16/10/2020	88
Dissolved Oxygen Field	%	DG_A_I_PZ_GW01	16/10/2020	51
Dissolved Oxygen Field	%	DG_A_I_PZ_BW45B	16/10/2020	3
Dissolved Oxygen Field	%	DG_A_I_PZ_GW05	19/10/2020	5

Variable	Unit	Sample Point	Date	Result
Dissolved Oxygen Field	%	DG_A_I_PZ_BW36A	19/10/2020	0
Dissolved Oxygen Field	%	DG_A_I_PZ_WRK300	19/10/2020	28
Dissolved Oxygen Field	%	DG_A_I_PZ_GW08	19/10/2020	79
Dissolved Oxygen Field	%	DG_A_I_PZ_WRK302	19/10/2020	70
Dissolved Oxygen Field	%	DG_A_I_PZ_GW06	19/10/2020	95
Dissolved Oxygen Field	%	DG_A_I_PZ_WRK304	20/10/2020	106
Dissolved Oxygen Field	%	DG_A_I_PZ_WRK303	20/10/2020	106
Dissolved Oxygen Field	%	DG_A_I_PZ_WRK301	20/10/2020	9
Dissolved Oxygen Field	%	DG_A_I_PZ_GW07	24/11/2020	88
Dissolved Oxygen Field	%	DG_A_I_PZ_GW03	24/11/2020	42
Dissolved Oxygen Field	%	DG_A_I_PZ_GW02	24/11/2020	9
Dissolved Oxygen Field	%	DG_A_I_PZ_GW01	24/11/2020	59
Dissolved Oxygen Field	%	DG_A_I_PZ_BW45B	24/11/2020	9
Dissolved Oxygen Field	%	DG_A_I_PZ_GW04	25/11/2020	86
Dissolved Oxygen Field	%	DG_A_I_PZ_GW05	25/11/2020	8
Dissolved Oxygen Field	%	DG_A_I_PZ_BW36A	25/11/2020	0.2
Dissolved Oxygen Field	%	DG_A_I_PZ_WRK300	25/11/2020	23
Dissolved Oxygen Field	%	DG_A_I_PZ_GW08	26/11/2020	74
Dissolved Oxygen Field	%	DG_A_I_PZ_WRK302	26/11/2020	70
Dissolved Oxygen Field	%	DG_A_I_PZ_GW06	26/11/2020	87
Dissolved Oxygen Field	%	DG_A_I_PZ_GW04A	30/11/2020	39
Dissolved Oxygen Field	%	DG_A_I_PZ_WRK304	30/11/2020	115
Dissolved Oxygen Field	%	DG_A_I_PZ_WRK303	30/11/2020	82
Dissolved Oxygen Field	%	DG_A_I_PZ_WRK301	30/11/2020	11
Dissolved Oxygen Field	%	DG_A_I_PZ_GW05	4/12/2020	0
Dissolved Oxygen Field	%	DG_A_I_PZ_GW07	8/12/2020	102
Dissolved Oxygen Field	%	DG_A_I_PZ_GW03	8/12/2020	52
Dissolved Oxygen Field	%	DG_A_I_PZ_GW02	8/12/2020	7
Dissolved Oxygen Field	%	DG_A_I_PZ_BW45B	9/12/2020	14
Dissolved Oxygen Field	%	DG_A_I_PZ_GW01	9/12/2020	54
Dissolved Oxygen Field	%	DG_A_I_PZ_GW04	9/12/2020	95
Dissolved Oxygen Field	%	DG_A_I_PZ_BW36A	9/12/2020	0
Dissolved Oxygen Field	%	DG_A_I_PZ_GW04A	10/12/2020	27
Dissolved Oxygen Field	%	DG_A_I_PZ_GW08	10/12/2020	77
Dissolved Oxygen Field	%	DG_A_I_PZ_WRK302	10/12/2020	77
Dissolved Oxygen Field	%	DG_A_I_PZ_GW06	10/12/2020	79
Dissolved Oxygen Field	%	DG_A_I_PZ_WRK304	14/12/2020	103
Dissolved Oxygen Field	%	DG_A_I_PZ_WRK303	14/12/2020	78
Dissolved Oxygen Field	%	DG_A_I_PZ_WRK301	14/12/2020	56
Dissolved Oxygen Field	%	DG_A_I_PZ_WRK300	14/12/2020	30
Electrical Conductivity	µS/cm	DG_A_I_PZ_GW07	2/07/2020	17000
Electrical Conductivity	µS/cm	DG_A_I_PZ_GW07	2/07/2020	17000
Electrical Conductivity	µS/cm	DG_A_I_PZ_GW03	2/07/2020	11000
Electrical Conductivity	µS/cm	DG_A_I_PZ_GW03	2/07/2020	11000

Variable	Unit	Sample Point	Date	Result
Electrical Conductivity	µS/cm	DG_A_I_PZ_GW02	2/07/2020	7300
Electrical Conductivity	µS/cm	DG_A_I_PZ_GW02	2/07/2020	7300
Electrical Conductivity	µS/cm	DG_A_I_PZ_GW08	6/07/2020	20000
Electrical Conductivity	µS/cm	DG_A_I_PZ_GW08	6/07/2020	20000
Electrical Conductivity	µS/cm	DG_A_I_PZ_WRK302	6/07/2020	20000
Electrical Conductivity	µS/cm	DG_A_I_PZ_WRK302	6/07/2020	20000
Electrical Conductivity	µS/cm	DG_A_I_PZ_GW06	6/07/2020	20000
Electrical Conductivity	µS/cm	DG_A_I_PZ_GW06	6/07/2020	20000
Electrical Conductivity	µS/cm	DG_A_I_PZ_BW36A	7/07/2020	6900
Electrical Conductivity	µS/cm	DG_A_I_PZ_BW36A	7/07/2020	6900
Electrical Conductivity	µS/cm	DG_A_I_PZ_GW01	7/07/2020	11000
Electrical Conductivity	µS/cm	DG_A_I_PZ_GW01	7/07/2020	11000
Electrical Conductivity	µS/cm	DG_A_I_PZ_BW45B	7/07/2020	16000
Electrical Conductivity	µS/cm	DG_A_I_PZ_BW45B	7/07/2020	16000
Electrical Conductivity	µS/cm	DG_A_I_PZ_IWB2	8/07/2020	4000
Electrical Conductivity	µS/cm	DG_A_I_PZ_IWB2	8/07/2020	4000
Electrical Conductivity	µS/cm	DG_A_I_PZ_IWB6	8/07/2020	1700
Electrical Conductivity	µS/cm	DG_A_I_PZ_IWB6	8/07/2020	1700
Electrical Conductivity	µS/cm	DG_A_I_PZ_BW05	8/07/2020	23000
Electrical Conductivity	µS/cm	DG_A_I_PZ_BW05	8/07/2020	23000
Electrical Conductivity	µS/cm	DG_A_I_PZ_BW28A	8/07/2020	21000
Electrical Conductivity	µS/cm	DG_A_I_PZ_BW28A	8/07/2020	21000
Electrical Conductivity	µS/cm	DG_A_I_PZ_BW53/Puls	9/07/2020	3000
Electrical Conductivity	µS/cm	DG_A_I_PZ_BW53/Puls	9/07/2020	3000
Electrical Conductivity	µS/cm	DG_A_I_PZ_GW05	9/07/2020	9000
Electrical Conductivity	µS/cm	DG_A_I_PZ_GW05	9/07/2020	9000
Electrical Conductivity	µS/cm	DG_A_I_PZ_GW04	9/07/2020	9500
Electrical Conductivity	µS/cm	DG_A_I_PZ_GW04	9/07/2020	9500
Electrical Conductivity	µS/cm	DG_A_I_PZ_WRK300	13/07/2020	6100
Electrical Conductivity	µS/cm	DG_A_I_PZ_WRK300	13/07/2020	6100
Electrical Conductivity	µS/cm	DG_A_I_PZ_WRK303	13/07/2020	9300
Electrical Conductivity	µS/cm	DG_A_I_PZ_WRK303	13/07/2020	9300
Electrical Conductivity	µS/cm	DG_A_I_PZ_WRK301	13/07/2020	11000
Electrical Conductivity	µS/cm	DG_A_I_PZ_WRK301	13/07/2020	11000
Electrical Conductivity	µS/cm	DG_A_I_PZ_WRK304	14/07/2020	8700
Electrical Conductivity	µS/cm	DG_A_I_PZ_WRK304	14/07/2020	8700
Electrical Conductivity	µS/cm	DG_A_I_PZ_GW04	10/08/2020	9200
Electrical Conductivity	µS/cm	DG_A_I_PZ_BW28A	10/08/2020	21000
Electrical Conductivity	µS/cm	DG_A_I_PZ_BW28A	10/08/2020	21000
Electrical Conductivity	µS/cm	DG_A_I_PZ_GW02	10/08/2020	7300
Electrical Conductivity	µS/cm	DG_A_I_PZ_GW02	10/08/2020	7300
Electrical Conductivity	µS/cm	DG_A_I_PZ_GW01	10/08/2020	11000
Electrical Conductivity	µS/cm	DG_A_I_PZ_GW01	10/08/2020	11000
Electrical Conductivity	µS/cm	DG_A_I_PZ_GW04	10/08/2020	9200

Variable	Unit	Sample Point	Date	Result
Electrical Conductivity	µS/cm	DG_A_I_PZ_BW36A	17/08/2020	7000
Electrical Conductivity	µS/cm	DG_A_I_PZ_BW53/Puls	17/08/2020	2700
Electrical Conductivity	µS/cm	DG_A_I_PZ_BW53/Puls	17/08/2020	2700
Electrical Conductivity	µS/cm	DG_A_I_PZ_GW05	17/08/2020	8900
Electrical Conductivity	µS/cm	DG_A_I_PZ_GW05	17/08/2020	8900
Electrical Conductivity	µS/cm	DG_A_I_PZ_BW36A	17/08/2020	7000
Electrical Conductivity	µS/cm	DG_A_I_PZ_WRK303	19/08/2020	9500
Electrical Conductivity	µS/cm	DG_A_I_PZ_WRK303	19/08/2020	9500
Electrical Conductivity	µS/cm	DG_A_I_PZ_BW45B	19/08/2020	16000
Electrical Conductivity	µS/cm	DG_A_I_PZ_WRK304	19/08/2020	8600
Electrical Conductivity	µS/cm	DG_A_I_PZ_WRK304	19/08/2020	8600
Electrical Conductivity	µS/cm	DG_A_I_PZ_BW45B	19/08/2020	16000
Electrical Conductivity	µS/cm	DG_A_I_PZ_GW07	20/08/2020	18888
Electrical Conductivity	µS/cm	DG_A_I_PZ_GW03	20/08/2020	11713
Electrical Conductivity	µS/cm	DG_A_I_PZ_WRK300	20/08/2020	6517
Electrical Conductivity	µS/cm	DG_A_I_PZ_GW06	25/08/2020	21691
Electrical Conductivity	µS/cm	DG_A_I_PZ_GW08	25/08/2020	21616
Electrical Conductivity	µS/cm	DG_A_I_PZ_WRK302	25/08/2020	21011
Electrical Conductivity	µS/cm	DG_A_I_PZ_WRK301	25/08/2020	11417
Electrical Conductivity	µS/cm	DG_A_I_PZ_WRK302	3/09/2020	20000
Electrical Conductivity	µS/cm	DG_A_I_PZ_WRK302	3/09/2020	20000
Electrical Conductivity	µS/cm	DG_A_I_PZ_GW03	3/09/2020	11486
Electrical Conductivity	µS/cm	DG_A_I_PZ_GW02	3/09/2020	7765
Electrical Conductivity	µS/cm	DG_A_I_PZ_GW07	7/09/2020	18900
Electrical Conductivity	µS/cm	DG_A_I_PZ_GW05	7/09/2020	9557
Electrical Conductivity	µS/cm	DG_A_I_PZ_GW04	7/09/2020	10023
Electrical Conductivity	µS/cm	DG_A_I_PZ_BW36A	7/09/2020	7812
Electrical Conductivity	µS/cm	DG_A_I_PZ_GW01	7/09/2020	11659
Electrical Conductivity	µS/cm	DG_A_I_PZ_BW45B	7/09/2020	17457
Electrical Conductivity	µS/cm	DG_A_I_PZ_GW08	8/09/2020	21795
Electrical Conductivity	µS/cm	DG_A_I_PZ_GW06	8/09/2020	21757
Electrical Conductivity	µS/cm	DG_A_I_PZ_WRK300	8/09/2020	6545
Electrical Conductivity	µS/cm	DG_A_I_PZ_WRK304	9/09/2020	10383
Electrical Conductivity	µS/cm	DG_A_I_PZ_WRK303	9/09/2020	9736
Electrical Conductivity	µS/cm	DG_A_I_PZ_WRK301	9/09/2020	11665
Electrical Conductivity	µS/cm	DG_A_I_PZ_GW04	15/10/2020	9600
Electrical Conductivity	µS/cm	DG_A_I_PZ_GW04	15/10/2020	9600
Electrical Conductivity	µS/cm	DG_A_I_PZ_GW03	15/10/2020	10785
Electrical Conductivity	µS/cm	DG_A_I_PZ_GW02	15/10/2020	7252
Electrical Conductivity	µS/cm	DG_A_I_PZ_GW07	16/10/2020	17593
Electrical Conductivity	µS/cm	DG_A_I_PZ_GW01	16/10/2020	10850
Electrical Conductivity	µS/cm	DG_A_I_PZ_BW45B	16/10/2020	16373
Electrical Conductivity	µS/cm	DG_A_I_PZ_GW05	19/10/2020	8917
Electrical Conductivity	µS/cm	DG_A_I_PZ_BW36A	19/10/2020	7550

Variable	Unit	Sample Point	Date	Result
Electrical Conductivity	µS/cm	DG_A_I_PZ_WRK300	19/10/2020	5980
Electrical Conductivity	µS/cm	DG_A_I_PZ_GW08	19/10/2020	20280
Electrical Conductivity	µS/cm	DG_A_I_PZ_WRK302	19/10/2020	19542
Electrical Conductivity	µS/cm	DG_A_I_PZ_GW06	19/10/2020	20316
Electrical Conductivity	µS/cm	DG_A_I_PZ_WRK304	20/10/2020	9239
Electrical Conductivity	µS/cm	DG_A_I_PZ_WRK303	20/10/2020	9518
Electrical Conductivity	µS/cm	DG_A_I_PZ_WRK301	20/10/2020	10424
Electrical Conductivity	µS/cm	DG_A_I_PZ_GW07	24/11/2020	18801
Electrical Conductivity	µS/cm	DG_A_I_PZ_GW03	24/11/2020	11404
Electrical Conductivity	µS/cm	DG_A_I_PZ_GW02	24/11/2020	7775
Electrical Conductivity	µS/cm	DG_A_I_PZ_GW01	24/11/2020	11598
Electrical Conductivity	µS/cm	DG_A_I_PZ_BW45B	24/11/2020	17600
Electrical Conductivity	µS/cm	DG_A_I_PZ_GW04	25/11/2020	10037
Electrical Conductivity	µS/cm	DG_A_I_PZ_GW05	25/11/2020	9663
Electrical Conductivity	µS/cm	DG_A_I_PZ_BW36A	25/11/2020	8359
Electrical Conductivity	µS/cm	DG_A_I_PZ_WRK300	25/11/2020	6515
Electrical Conductivity	µS/cm	DG_A_I_PZ_GW08	26/11/2020	21486
Electrical Conductivity	µS/cm	DG_A_I_PZ_WRK302	26/11/2020	20873
Electrical Conductivity	µS/cm	DG_A_I_PZ_GW06	26/11/2020	21679
Electrical Conductivity	µS/cm	DG_A_I_PZ_GW04A	30/11/2020	8100
Electrical Conductivity	µS/cm	DG_A_I_PZ_GW04A	30/11/2020	8100
Electrical Conductivity	µS/cm	DG_A_I_PZ_WRK304	30/11/2020	9412
Electrical Conductivity	µS/cm	DG_A_I_PZ_WRK303	30/11/2020	10092
Electrical Conductivity	µS/cm	DG_A_I_PZ_WRK301	30/11/2020	12865
Electrical Conductivity	µS/cm	DG_A_I_PZ_GW05	4/12/2020	9439
Electrical Conductivity	µS/cm	DG_A_I_PZ_GW07	8/12/2020	18327
Electrical Conductivity	µS/cm	DG_A_I_PZ_GW03	8/12/2020	11213
Electrical Conductivity	µS/cm	DG_A_I_PZ_GW02	8/12/2020	7628
Electrical Conductivity	µS/cm	DG_A_I_PZ_BW45B	9/12/2020	17042
Electrical Conductivity	µS/cm	DG_A_I_PZ_GW01	9/12/2020	11241
Electrical Conductivity	µS/cm	DG_A_I_PZ_GW04	9/12/2020	9756
Electrical Conductivity	µS/cm	DG_A_I_PZ_BW36A	9/12/2020	8250
Electrical Conductivity	µS/cm	DG_A_I_PZ_GW04A	10/12/2020	8279
Electrical Conductivity	µS/cm	DG_A_I_PZ_GW08	10/12/2020	21180
Electrical Conductivity	µS/cm	DG_A_I_PZ_WRK302	10/12/2020	20254
Electrical Conductivity	µS/cm	DG_A_I_PZ_GW06	10/12/2020	21063
Electrical Conductivity	µS/cm	DG_A_I_PZ_WRK304	14/12/2020	9205
Electrical Conductivity	µS/cm	DG_A_I_PZ_WRK303	14/12/2020	10143
Electrical Conductivity	µS/cm	DG_A_I_PZ_WRK301	14/12/2020	11410
Electrical Conductivity	µS/cm	DG_A_I_PZ_WRK300	14/12/2020	6346
Electrical Conductivity	µS/cm	DG_A_I_PZ_GW04A	30/12/2020	8100
Fluoride	mg/L	DG_A_I_PZ_GW07	2/07/2020	0.36
Fluoride	mg/L	DG_A_I_PZ_GW03	2/07/2020	0.24
Fluoride	mg/L	DG_A_I_PZ_GW02	2/07/2020	0.1

Variable	Unit	Sample Point	Date	Result
Fluoride	mg/L	DG_A_I_PZ_GW08	6/07/2020	0.23
Fluoride	mg/L	DG_A_I_PZ_WRK302	6/07/2020	0.57
Fluoride	mg/L	DG_A_I_PZ_GW06	6/07/2020	0.27
Fluoride	mg/L	DG_A_I_PZ_BW36A	7/07/2020	0.6
Fluoride	mg/L	DG_A_I_PZ_GW01	7/07/2020	0.75
Fluoride	mg/L	DG_A_I_PZ_BW45B	7/07/2020	1.2
Fluoride	mg/L	DG_A_I_PZ_IWB2	8/07/2020	0.18
Fluoride	mg/L	DG_A_I_PZ_IWB6	8/07/2020	0.1
Fluoride	mg/L	DG_A_I_PZ_BW05	8/07/2020	0.56
Fluoride	mg/L	DG_A_I_PZ_BW28A	8/07/2020	0.52
Fluoride	mg/L	DG_A_I_PZ_BW53/Puls	9/07/2020	0.13
Fluoride	mg/L	DG_A_I_PZ_GW05	9/07/2020	0.13
Fluoride	mg/L	DG_A_I_PZ_GW04	9/07/2020	0.16
Fluoride	mg/L	DG_A_I_PZ_WRK300	13/07/2020	0.36
Fluoride	mg/L	DG_A_I_PZ_WRK303	13/07/2020	0.29
Fluoride	mg/L	DG_A_I_PZ_WRK301	13/07/2020	0.58
Fluoride	mg/L	DG_A_I_PZ_WRK304	14/07/2020	0.41
Fluoride	mg/L	DG_A_I_PZ_GW04	10/08/2020	0.17
Fluoride	mg/L	DG_A_I_PZ_BW28A	10/08/2020	0.41
Fluoride	mg/L	DG_A_I_PZ_GW02	10/08/2020	0.1
Fluoride	mg/L	DG_A_I_PZ_GW01	10/08/2020	0.76
Fluoride	mg/L	DG_A_I_PZ_BW36A	17/08/2020	0.67
Fluoride	mg/L	DG_A_I_PZ_BW53/Puls	17/08/2020	0.14
Fluoride	mg/L	DG_A_I_PZ_GW05	17/08/2020	0.15
Fluoride	mg/L	DG_A_I_PZ_WRK303	19/08/2020	0.32
Fluoride	mg/L	DG_A_I_PZ_BW45B	19/08/2020	1.1
Fluoride	mg/L	DG_A_I_PZ_WRK304	19/08/2020	0.45
Fluoride	mg/L	DG_A_I_PZ_WRK302	3/09/2020	0.57
Fluoride	mg/L	DG_A_I_PZ_GW04	15/10/2020	0.15
Fluoride	mg/L	DG_A_I_PZ_GW04A	30/11/2020	0.31
Fluoride	mg/L	DG_A_I_PZ_GW04A	30/12/2020	0.31
Iron (Total)	mg/L	DG_A_I_PZ_GW07	2/07/2020	0.01
Iron (Total)	mg/L	DG_A_I_PZ_GW03	2/07/2020	1.6
Iron (Total)	mg/L	DG_A_I_PZ_GW02	2/07/2020	0.02
Iron (Total)	mg/L	DG_A_I_PZ_GW08	6/07/2020	0.02
Iron (Total)	mg/L	DG_A_I_PZ_WRK302	6/07/2020	0.01
Iron (Total)	mg/L	DG_A_I_PZ_GW06	6/07/2020	0.09
Iron (Total)	mg/L	DG_A_I_PZ_BW36A	7/07/2020	9.1
Iron (Total)	mg/L	DG_A_I_PZ_GW01	7/07/2020	0.06
Iron (Total)	mg/L	DG_A_I_PZ_BW45B	7/07/2020	0.08
Iron (Total)	mg/L	DG_A_I_PZ_IWB2	8/07/2020	0.06
Iron (Total)	mg/L	DG_A_I_PZ_IWB6	8/07/2020	0.45
Iron (Total)	mg/L	DG_A_I_PZ_BW05	8/07/2020	0.67
Iron (Total)	mg/L	DG_A_I_PZ_BW28A	8/07/2020	7.6

Variable	Unit	Sample Point	Date	Result
Iron (Total)	mg/L	DG_A_I_PZ_BW53/Puls	9/07/2020	0.45
Iron (Total)	mg/L	DG_A_I_PZ_GW05	9/07/2020	0.01
Iron (Total)	mg/L	DG_A_I_PZ_GW04	9/07/2020	0.01
Iron (Total)	mg/L	DG_A_I_PZ_WRK300	13/07/2020	0.01
Iron (Total)	mg/L	DG_A_I_PZ_WRK303	13/07/2020	0.02
Iron (Total)	mg/L	DG_A_I_PZ_WRK301	13/07/2020	0.04
Iron (Total)	mg/L	DG_A_I_PZ_WRK304	14/07/2020	0.06
Iron (Total)	mg/L	DG_A_I_PZ_GW04	10/08/2020	0.01
Iron (Total)	mg/L	DG_A_I_PZ_BW28A	10/08/2020	5.4
Iron (Total)	mg/L	DG_A_I_PZ_GW02	10/08/2020	0.04
Iron (Total)	mg/L	DG_A_I_PZ_GW01	10/08/2020	0.05
Iron (Total)	mg/L	DG_A_I_PZ_BW36A	17/08/2020	11
Iron (Total)	mg/L	DG_A_I_PZ_BW53/Puls	17/08/2020	0.53
Iron (Total)	mg/L	DG_A_I_PZ_GW05	17/08/2020	0.01
Iron (Total)	mg/L	DG_A_I_PZ_WRK303	19/08/2020	0.01
Iron (Total)	mg/L	DG_A_I_PZ_BW45B	19/08/2020	0.05
Iron (Total)	mg/L	DG_A_I_PZ_WRK304	19/08/2020	0.11
Iron (Total)	mg/L	DG_A_I_PZ_WRK302	3/09/2020	0.01
Iron (Total)	mg/L	DG_A_I_PZ_GW04	15/10/2020	0.01
Iron (Total)	mg/L	DG_A_I_PZ_GW04A	30/11/2020	0.01
Iron (Total)	mg/L	DG_A_I_PZ_GW04A	30/12/2020	0.01
Lead (Total)	mg/L	DG_A_I_PZ_GW07	2/07/2020	0.001
Lead (Total)	mg/L	DG_A_I_PZ_GW03	2/07/2020	0.001
Lead (Total)	mg/L	DG_A_I_PZ_GW02	2/07/2020	0.001
Lead (Total)	mg/L	DG_A_I_PZ_GW08	6/07/2020	0.001
Lead (Total)	mg/L	DG_A_I_PZ_WRK302	6/07/2020	0.005
Lead (Total)	mg/L	DG_A_I_PZ_GW06	6/07/2020	0.001
Lead (Total)	mg/L	DG_A_I_PZ_BW36A	7/07/2020	0.001
Lead (Total)	mg/L	DG_A_I_PZ_GW01	7/07/2020	0.002
Lead (Total)	mg/L	DG_A_I_PZ_BW45B	7/07/2020	0.025
Lead (Total)	mg/L	DG_A_I_PZ_IWB2	8/07/2020	0.001
Lead (Total)	mg/L	DG_A_I_PZ_IWB6	8/07/2020	0.001
Lead (Total)	mg/L	DG_A_I_PZ_BW05	8/07/2020	0.001
Lead (Total)	mg/L	DG_A_I_PZ_BW28A	8/07/2020	0.001
Lead (Total)	mg/L	DG_A_I_PZ_BW53/Puls	9/07/2020	0.001
Lead (Total)	mg/L	DG_A_I_PZ_GW05	9/07/2020	0.001
Lead (Total)	mg/L	DG_A_I_PZ_GW04	9/07/2020	0.001
Lead (Total)	mg/L	DG_A_I_PZ_WRK300	13/07/2020	0.001
Lead (Total)	mg/L	DG_A_I_PZ_WRK303	13/07/2020	0.001
Lead (Total)	mg/L	DG_A_I_PZ_WRK301	13/07/2020	0.001
Lead (Total)	mg/L	DG_A_I_PZ_WRK304	14/07/2020	0.001
Lead (Total)	mg/L	DG_A_I_PZ_GW04	10/08/2020	0.001
Lead (Total)	mg/L	DG_A_I_PZ_BW28A	10/08/2020	0.001
Lead (Total)	mg/L	DG_A_I_PZ_GW02	10/08/2020	0.001

Variable	Unit	Sample Point	Date	Result
Lead (Total)	mg/L	DG_A_I_PZ_GW01	10/08/2020	0.001
Lead (Total)	mg/L	DG_A_I_PZ_BW36A	17/08/2020	0.001
Lead (Total)	mg/L	DG_A_I_PZ_BW53/Puls	17/08/2020	0.001
Lead (Total)	mg/L	DG_A_I_PZ_GW05	17/08/2020	0.001
Lead (Total)	mg/L	DG_A_I_PZ_WRK303	19/08/2020	0.001
Lead (Total)	mg/L	DG_A_I_PZ_BW45B	19/08/2020	0.009
Lead (Total)	mg/L	DG_A_I_PZ_WRK304	19/08/2020	0.001
Lead (Total)	mg/L	DG_A_I_PZ_WRK302	3/09/2020	0.006
Lead (Total)	mg/L	DG_A_I_PZ_GW04	15/10/2020	0.001
Lead (Total)	mg/L	DG_A_I_PZ_GW04A	30/11/2020	0.001
Lead (Total)	mg/L	DG_A_I_PZ_GW04A	30/12/2020	0.001
Magnesium	mg/L	DG_A_I_PZ_GW07	2/07/2020	310
Magnesium	mg/L	DG_A_I_PZ_GW03	2/07/2020	200
Magnesium	mg/L	DG_A_I_PZ_GW02	2/07/2020	140
Magnesium	mg/L	DG_A_I_PZ_GW08	6/07/2020	480
Magnesium	mg/L	DG_A_I_PZ_WRK302	6/07/2020	400
Magnesium	mg/L	DG_A_I_PZ_GW06	6/07/2020	490
Magnesium	mg/L	DG_A_I_PZ_BW36A	7/07/2020	120
Magnesium	mg/L	DG_A_I_PZ_GW01	7/07/2020	230
Magnesium	mg/L	DG_A_I_PZ_BW45B	7/07/2020	320
Magnesium	mg/L	DG_A_I_PZ_IWB2	8/07/2020	81
Magnesium	mg/L	DG_A_I_PZ_IWB6	8/07/2020	19
Magnesium	mg/L	DG_A_I_PZ_BW05	8/07/2020	460
Magnesium	mg/L	DG_A_I_PZ_BW28A	8/07/2020	530
Magnesium	mg/L	DG_A_I_PZ_BW53/Puls	9/07/2020	56
Magnesium	mg/L	DG_A_I_PZ_GW05	9/07/2020	100
Magnesium	mg/L	DG_A_I_PZ_GW04	9/07/2020	160
Magnesium	mg/L	DG_A_I_PZ_WRK300	13/07/2020	120
Magnesium	mg/L	DG_A_I_PZ_WRK303	13/07/2020	160
Magnesium	mg/L	DG_A_I_PZ_WRK301	13/07/2020	260
Magnesium	mg/L	DG_A_I_PZ_WRK304	14/07/2020	120
Magnesium	mg/L	DG_A_I_PZ_GW04	10/08/2020	160
Magnesium	mg/L	DG_A_I_PZ_BW28A	10/08/2020	520
Magnesium	mg/L	DG_A_I_PZ_GW02	10/08/2020	150
Magnesium	mg/L	DG_A_I_PZ_GW01	10/08/2020	240
Magnesium	mg/L	DG_A_I_PZ_BW36A	17/08/2020	110
Magnesium	mg/L	DG_A_I_PZ_BW53/Puls	17/08/2020	52
Magnesium	mg/L	DG_A_I_PZ_GW05	17/08/2020	100
Magnesium	mg/L	DG_A_I_PZ_WRK303	19/08/2020	150
Magnesium	mg/L	DG_A_I_PZ_BW45B	19/08/2020	320
Magnesium	mg/L	DG_A_I_PZ_WRK304	19/08/2020	120
Magnesium	mg/L	DG_A_I_PZ_WRK302	3/09/2020	390
Magnesium	mg/L	DG_A_I_PZ_GW04	15/10/2020	150
Magnesium	mg/L	DG_A_I_PZ_GW04A	30/11/2020	140

Variable	Unit	Sample Point	Date	Result
Magnesium	mg/L	DG_A_I_PZ_GW04A	30/12/2020	140
Manganese (Total)	mg/L	DG_A_I_PZ_GW07	2/07/2020	0.006
Manganese (Total)	mg/L	DG_A_I_PZ_GW03	2/07/2020	0.74
Manganese (Total)	mg/L	DG_A_I_PZ_GW02	2/07/2020	0.48
Manganese (Total)	mg/L	DG_A_I_PZ_GW08	6/07/2020	0.004
Manganese (Total)	mg/L	DG_A_I_PZ_WRK302	6/07/2020	0.015
Manganese (Total)	mg/L	DG_A_I_PZ_GW06	6/07/2020	0.017
Manganese (Total)	mg/L	DG_A_I_PZ_BW36A	7/07/2020	4
Manganese (Total)	mg/L	DG_A_I_PZ_GW01	7/07/2020	0.011
Manganese (Total)	mg/L	DG_A_I_PZ_BW45B	7/07/2020	0.052
Manganese (Total)	mg/L	DG_A_I_PZ_IWB2	8/07/2020	0.008
Manganese (Total)	mg/L	DG_A_I_PZ_IWB6	8/07/2020	0.011
Manganese (Total)	mg/L	DG_A_I_PZ_BW05	8/07/2020	0.12
Manganese (Total)	mg/L	DG_A_I_PZ_BW28A	8/07/2020	1.5
Manganese (Total)	mg/L	DG_A_I_PZ_BW53/Puls	9/07/2020	0.04
Manganese (Total)	mg/L	DG_A_I_PZ_GW05	9/07/2020	0.018
Manganese (Total)	mg/L	DG_A_I_PZ_GW04	9/07/2020	0.037
Manganese (Total)	mg/L	DG_A_I_PZ_WRK300	13/07/2020	0.047
Manganese (Total)	mg/L	DG_A_I_PZ_WRK303	13/07/2020	0.057
Manganese (Total)	mg/L	DG_A_I_PZ_WRK301	13/07/2020	0.015
Manganese (Total)	mg/L	DG_A_I_PZ_WRK304	14/07/2020	0.006
Manganese (Total)	mg/L	DG_A_I_PZ_GW04	10/08/2020	0.034
Manganese (Total)	mg/L	DG_A_I_PZ_BW28A	10/08/2020	1.6
Manganese (Total)	mg/L	DG_A_I_PZ_GW02	10/08/2020	0.53
Manganese (Total)	mg/L	DG_A_I_PZ_GW01	10/08/2020	0.007
Manganese (Total)	mg/L	DG_A_I_PZ_BW36A	17/08/2020	4.3
Manganese (Total)	mg/L	DG_A_I_PZ_BW53/Puls	17/08/2020	0.03
Manganese (Total)	mg/L	DG_A_I_PZ_GW05	17/08/2020	0.015
Manganese (Total)	mg/L	DG_A_I_PZ_WRK303	19/08/2020	0.004
Manganese (Total)	mg/L	DG_A_I_PZ_BW45B	19/08/2020	0.058
Manganese (Total)	mg/L	DG_A_I_PZ_WRK304	19/08/2020	0.007
Manganese (Total)	mg/L	DG_A_I_PZ_WRK302	3/09/2020	0.018
Manganese (Total)	mg/L	DG_A_I_PZ_GW04	15/10/2020	0.033
Manganese (Total)	mg/L	DG_A_I_PZ_GW04A	30/11/2020	0.056
Manganese (Total)	mg/L	DG_A_I_PZ_GW04A	30/12/2020	0.056
Mercury (Total)	mg/L	DG_A_I_PZ_GW07	2/07/2020	0.0002
Mercury (Total)	mg/L	DG_A_I_PZ_GW03	2/07/2020	0.0001
Mercury (Total)	mg/L	DG_A_I_PZ_GW02	2/07/2020	0.0001
Mercury (Total)	mg/L	DG_A_I_PZ_GW08	6/07/2020	0.0001
Mercury (Total)	mg/L	DG_A_I_PZ_WRK302	6/07/2020	0.0001
Mercury (Total)	mg/L	DG_A_I_PZ_GW06	6/07/2020	0.0001
Mercury (Total)	mg/L	DG_A_I_PZ_BW36A	7/07/2020	0.0001
Mercury (Total)	mg/L	DG_A_I_PZ_GW01	7/07/2020	0.0001
Mercury (Total)	mg/L	DG_A_I_PZ_BW45B	7/07/2020	0.0001

Variable	Unit	Sample Point	Date	Result
Mercury (Total)	mg/L	DG_A_I_PZ_IWB2	8/07/2020	0.0001
Mercury (Total)	mg/L	DG_A_I_PZ_IWB6	8/07/2020	0.0001
Mercury (Total)	mg/L	DG_A_I_PZ_BW05	8/07/2020	0.0001
Mercury (Total)	mg/L	DG_A_I_PZ_BW28A	8/07/2020	0.0001
Mercury (Total)	mg/L	DG_A_I_PZ_BW53/Puls	9/07/2020	0.0001
Mercury (Total)	mg/L	DG_A_I_PZ_GW05	9/07/2020	0.0001
Mercury (Total)	mg/L	DG_A_I_PZ_GW04	9/07/2020	0.0001
Mercury (Total)	mg/L	DG_A_I_PZ_WRK300	13/07/2020	0.0001
Mercury (Total)	mg/L	DG_A_I_PZ_WRK303	13/07/2020	0.0001
Mercury (Total)	mg/L	DG_A_I_PZ_WRK301	13/07/2020	0.0001
Mercury (Total)	mg/L	DG_A_I_PZ_WRK304	14/07/2020	0.0001
Mercury (Total)	mg/L	DG_A_I_PZ_GW04	10/08/2020	0.0001
Mercury (Total)	mg/L	DG_A_I_PZ_BW28A	10/08/2020	0.0001
Mercury (Total)	mg/L	DG_A_I_PZ_GW02	10/08/2020	0.0001
Mercury (Total)	mg/L	DG_A_I_PZ_GW01	10/08/2020	0.0001
Mercury (Total)	mg/L	DG_A_I_PZ_BW36A	17/08/2020	0.0001
Mercury (Total)	mg/L	DG_A_I_PZ_BW53/Puls	17/08/2020	0.0001
Mercury (Total)	mg/L	DG_A_I_PZ_GW05	17/08/2020	0.0001
Mercury (Total)	mg/L	DG_A_I_PZ_WRK303	19/08/2020	0.0001
Mercury (Total)	mg/L	DG_A_I_PZ_BW45B	19/08/2020	0.0001
Mercury (Total)	mg/L	DG_A_I_PZ_WRK304	19/08/2020	0.0001
Mercury (Total)	mg/L	DG_A_I_PZ_WRK302	3/09/2020	0.0001
Mercury (Total)	mg/L	DG_A_I_PZ_GW04	15/10/2020	0.0001
Mercury (Total)	mg/L	DG_A_I_PZ_GW04A	30/11/2020	0.0001
Mercury (Total)	mg/L	DG_A_I_PZ_GW04A	30/12/2020	0.0001
Molybdenum (Total)	mg/L	DG_A_I_PZ_GW07	2/07/2020	0.001
Molybdenum (Total)	mg/L	DG_A_I_PZ_GW03	2/07/2020	0.001
Molybdenum (Total)	mg/L	DG_A_I_PZ_GW02	2/07/2020	0.001
Molybdenum (Total)	mg/L	DG_A_I_PZ_GW08	6/07/2020	0.001
Molybdenum (Total)	mg/L	DG_A_I_PZ_WRK302	6/07/2020	0.001
Molybdenum (Total)	mg/L	DG_A_I_PZ_GW06	6/07/2020	0.001
Molybdenum (Total)	mg/L	DG_A_I_PZ_BW36A	7/07/2020	0.001
Molybdenum (Total)	mg/L	DG_A_I_PZ_GW01	7/07/2020	0.001
Molybdenum (Total)	mg/L	DG_A_I_PZ_BW45B	7/07/2020	0.001
Molybdenum (Total)	mg/L	DG_A_I_PZ_IWB2	8/07/2020	0.001
Molybdenum (Total)	mg/L	DG_A_I_PZ_IWB6	8/07/2020	0.001
Molybdenum (Total)	mg/L	DG_A_I_PZ_BW05	8/07/2020	0.002
Molybdenum (Total)	mg/L	DG_A_I_PZ_BW28A	8/07/2020	0.002
Molybdenum (Total)	mg/L	DG_A_I_PZ_BW53/Puls	9/07/2020	0.001
Molybdenum (Total)	mg/L	DG_A_I_PZ_GW05	9/07/2020	0.001
Molybdenum (Total)	mg/L	DG_A_I_PZ_GW04	9/07/2020	0.001
Molybdenum (Total)	mg/L	DG_A_I_PZ_WRK300	13/07/2020	0.001
Molybdenum (Total)	mg/L	DG_A_I_PZ_WRK303	13/07/2020	0.001
Molybdenum (Total)	mg/L	DG_A_I_PZ_WRK301	13/07/2020	0.001

Variable	Unit	Sample Point	Date	Result
Molybdenum (Total)	mg/L	DG_A_I_PZ_WRK304	14/07/2020	0.001
Molybdenum (Total)	mg/L	DG_A_I_PZ_GW04	10/08/2020	0.001
Molybdenum (Total)	mg/L	DG_A_I_PZ_BW28A	10/08/2020	0.002
Molybdenum (Total)	mg/L	DG_A_I_PZ_GW02	10/08/2020	0.001
Molybdenum (Total)	mg/L	DG_A_I_PZ_GW01	10/08/2020	0.001
Molybdenum (Total)	mg/L	DG_A_I_PZ_BW36A	17/08/2020	0.001
Molybdenum (Total)	mg/L	DG_A_I_PZ_BW53/Puls	17/08/2020	0.001
Molybdenum (Total)	mg/L	DG_A_I_PZ_GW05	17/08/2020	0.001
Molybdenum (Total)	mg/L	DG_A_I_PZ_WRK303	19/08/2020	0.001
Molybdenum (Total)	mg/L	DG_A_I_PZ_BW45B	19/08/2020	0.001
Molybdenum (Total)	mg/L	DG_A_I_PZ_WRK304	19/08/2020	0.001
Molybdenum (Total)	mg/L	DG_A_I_PZ_WRK302	3/09/2020	0.001
Molybdenum (Total)	mg/L	DG_A_I_PZ_GW04	15/10/2020	0.001
Molybdenum (Total)	mg/L	DG_A_I_PZ_GW04A	30/11/2020	0.001
Molybdenum (Total)	mg/L	DG_A_I_PZ_GW04A	30/12/2020	0.001
Nickel (Total)	mg/L	DG_A_I_PZ_GW07	2/07/2020	0.026
Nickel (Total)	mg/L	DG_A_I_PZ_GW03	2/07/2020	0.005
Nickel (Total)	mg/L	DG_A_I_PZ_GW02	2/07/2020	0.006
Nickel (Total)	mg/L	DG_A_I_PZ_GW08	6/07/2020	0.009
Nickel (Total)	mg/L	DG_A_I_PZ_WRK302	6/07/2020	0.02
Nickel (Total)	mg/L	DG_A_I_PZ_GW06	6/07/2020	0.015
Nickel (Total)	mg/L	DG_A_I_PZ_BW36A	7/07/2020	0.012
Nickel (Total)	mg/L	DG_A_I_PZ_GW01	7/07/2020	0.033
Nickel (Total)	mg/L	DG_A_I_PZ_BW45B	7/07/2020	0.058
Nickel (Total)	mg/L	DG_A_I_PZ_IWB2	8/07/2020	0.003
Nickel (Total)	mg/L	DG_A_I_PZ_IWB6	8/07/2020	0.002
Nickel (Total)	mg/L	DG_A_I_PZ_BW05	8/07/2020	0.001
Nickel (Total)	mg/L	DG_A_I_PZ_BW28A	8/07/2020	0.013
Nickel (Total)	mg/L	DG_A_I_PZ_BW53/Puls	9/07/2020	0.001
Nickel (Total)	mg/L	DG_A_I_PZ_GW05	9/07/2020	0.004
Nickel (Total)	mg/L	DG_A_I_PZ_GW04	9/07/2020	0.01
Nickel (Total)	mg/L	DG_A_I_PZ_WRK300	13/07/2020	0.002
Nickel (Total)	mg/L	DG_A_I_PZ_WRK303	13/07/2020	0.005
Nickel (Total)	mg/L	DG_A_I_PZ_WRK301	13/07/2020	0.002
Nickel (Total)	mg/L	DG_A_I_PZ_WRK304	14/07/2020	0.004
Nickel (Total)	mg/L	DG_A_I_PZ_GW04	10/08/2020	0.01
Nickel (Total)	mg/L	DG_A_I_PZ_BW28A	10/08/2020	0.014
Nickel (Total)	mg/L	DG_A_I_PZ_GW02	10/08/2020	0.006
Nickel (Total)	mg/L	DG_A_I_PZ_GW01	10/08/2020	0.029
Nickel (Total)	mg/L	DG_A_I_PZ_BW36A	17/08/2020	0.013
Nickel (Total)	mg/L	DG_A_I_PZ_BW53/Puls	17/08/2020	0.003
Nickel (Total)	mg/L	DG_A_I_PZ_GW05	17/08/2020	0.004
Nickel (Total)	mg/L	DG_A_I_PZ_WRK303	19/08/2020	0.004
Nickel (Total)	mg/L	DG_A_I_PZ_BW45B	19/08/2020	0.05

Variable	Unit	Sample Point	Date	Result
Nickel (Total)	mg/L	DG_A_I_PZ_WRK304	19/08/2020	0.003
Nickel (Total)	mg/L	DG_A_I_PZ_WRK302	3/09/2020	0.02
Nickel (Total)	mg/L	DG_A_I_PZ_GW04	15/10/2020	0.01
Nickel (Total)	mg/L	DG_A_I_PZ_GW04A	30/11/2020	0.005
Nickel (Total)	mg/L	DG_A_I_PZ_GW04A	30/12/2020	0.005
Nitrate-Nitrogen	mg/L	DG_A_I_PZ_GW07	2/07/2020	0.6
Nitrate-Nitrogen	mg/L	DG_A_I_PZ_GW03	2/07/2020	2
Nitrate-Nitrogen	mg/L	DG_A_I_PZ_GW02	2/07/2020	7.8
Nitrate-Nitrogen	mg/L	DG_A_I_PZ_GW08	6/07/2020	0.32
Nitrate-Nitrogen	mg/L	DG_A_I_PZ_WRK302	6/07/2020	0.34
Nitrate-Nitrogen	mg/L	DG_A_I_PZ_GW06	6/07/2020	0.13
Nitrate-Nitrogen	mg/L	DG_A_I_PZ_BW36A	7/07/2020	0.12
Nitrate-Nitrogen	mg/L	DG_A_I_PZ_GW01	7/07/2020	1.5
Nitrate-Nitrogen	mg/L	DG_A_I_PZ_BW45B	7/07/2020	0.15
Nitrate-Nitrogen	mg/L	DG_A_I_PZ_IWB2	8/07/2020	4
Nitrate-Nitrogen	mg/L	DG_A_I_PZ_IWB6	8/07/2020	8.2
Nitrate-Nitrogen	mg/L	DG_A_I_PZ_BW05	8/07/2020	1
Nitrate-Nitrogen	mg/L	DG_A_I_PZ_BW28A	8/07/2020	0.2
Nitrate-Nitrogen	mg/L	DG_A_I_PZ_BW53/Puls	9/07/2020	2.7
Nitrate-Nitrogen	mg/L	DG_A_I_PZ_GW05	9/07/2020	4
Nitrate-Nitrogen	mg/L	DG_A_I_PZ_GW04	9/07/2020	3.3
Nitrate-Nitrogen	mg/L	DG_A_I_PZ_WRK300	13/07/2020	1.2
Nitrate-Nitrogen	mg/L	DG_A_I_PZ_WRK303	13/07/2020	1.2
Nitrate-Nitrogen	mg/L	DG_A_I_PZ_WRK301	13/07/2020	0.18
Nitrate-Nitrogen	mg/L	DG_A_I_PZ_WRK304	14/07/2020	2.1
Nitrate-Nitrogen	mg/L	DG_A_I_PZ_GW04	10/08/2020	3.5
Nitrate-Nitrogen	mg/L	DG_A_I_PZ_BW28A	10/08/2020	0.29
Nitrate-Nitrogen	mg/L	DG_A_I_PZ_GW02	10/08/2020	7.1
Nitrate-Nitrogen	mg/L	DG_A_I_PZ_GW01	10/08/2020	1.4
Nitrate-Nitrogen	mg/L	DG_A_I_PZ_BW36A	17/08/2020	0.02
Nitrate-Nitrogen	mg/L	DG_A_I_PZ_BW53/Puls	17/08/2020	3.8
Nitrate-Nitrogen	mg/L	DG_A_I_PZ_GW05	17/08/2020	4.5
Nitrate-Nitrogen	mg/L	DG_A_I_PZ_WRK303	19/08/2020	2.6
Nitrate-Nitrogen	mg/L	DG_A_I_PZ_BW45B	19/08/2020	0.18
Nitrate-Nitrogen	mg/L	DG_A_I_PZ_WRK304	19/08/2020	2.2
Nitrate-Nitrogen	mg/L	DG_A_I_PZ_WRK302	3/09/2020	0.31
Nitrate-Nitrogen	mg/L	DG_A_I_PZ_GW04	15/10/2020	3.6
Nitrate-Nitrogen	mg/L	DG_A_I_PZ_GW04A	30/11/2020	4
Nitrate-Nitrogen	mg/L	DG_A_I_PZ_GW04A	30/12/2020	4
Nitrite (Total)	mg/L	DG_A_I_PZ_GW07	2/07/2020	0.0033
Nitrite (Total)	mg/L	DG_A_I_PZ_GW03	2/07/2020	0.0395
Nitrite (Total)	mg/L	DG_A_I_PZ_GW02	2/07/2020	0.0823
Nitrite (Total)	mg/L	DG_A_I_PZ_GW08	6/07/2020	0.0033
Nitrite (Total)	mg/L	DG_A_I_PZ_WRK302	6/07/2020	0.0033

Variable	Unit	Sample Point	Date	Result
Nitrite (Total)	mg/L	DG_A_I_PZ_GW06	6/07/2020	0.0033
Nitrite (Total)	mg/L	DG_A_I_PZ_GW01	7/07/2020	0.0033
Nitrite (Total)	mg/L	DG_A_I_PZ_BW45B	7/07/2020	0.0263
Nitrite (Total)	mg/L	DG_A_I_PZ_IWB2	8/07/2020	0.0066
Nitrite (Total)	mg/L	DG_A_I_PZ_IWB6	8/07/2020	0.0132
Nitrite (Total)	mg/L	DG_A_I_PZ_BW05	8/07/2020	0.0033
Nitrite (Total)	mg/L	DG_A_I_PZ_BW28A	8/07/2020	0.0428
Nitrite (Total)	mg/L	DG_A_I_PZ_BW53/Puls	9/07/2020	0.0263
Nitrite (Total)	mg/L	DG_A_I_PZ_GW05	9/07/2020	0.3224
Nitrite (Total)	mg/L	DG_A_I_PZ_GW04	9/07/2020	0.0428
Nitrite (Total)	mg/L	DG_A_I_PZ_WRK300	13/07/2020	0.1711
Nitrite (Total)	mg/L	DG_A_I_PZ_WRK303	13/07/2020	0.0033
Nitrite (Total)	mg/L	DG_A_I_PZ_WRK301	13/07/2020	0.0066
Nitrite (Total)	mg/L	DG_A_I_PZ_WRK304	14/07/2020	0.0033
Nitrite (Total)	mg/L	DG_A_I_PZ_GW04	10/08/2020	0.0461
Nitrite (Total)	mg/L	DG_A_I_PZ_BW28A	10/08/2020	0.0197
Nitrite (Total)	mg/L	DG_A_I_PZ_GW02	10/08/2020	0.0954
Nitrite (Total)	mg/L	DG_A_I_PZ_GW01	10/08/2020	0.0132
Nitrite (Total)	mg/L	DG_A_I_PZ_BW53/Puls	17/08/2020	0.1481
Nitrite (Total)	mg/L	DG_A_I_PZ_GW05	17/08/2020	0.3158
Nitrite (Total)	mg/L	DG_A_I_PZ_WRK303	19/08/2020	0.0033
Nitrite (Total)	mg/L	DG_A_I_PZ_BW45B	19/08/2020	0.0559
Nitrite (Total)	mg/L	DG_A_I_PZ_WRK304	19/08/2020	0.0066
Nitrite (Total)	mg/L	DG_A_I_PZ_WRK302	3/09/2020	0.0033
Nitrite (Total)	mg/L	DG_A_I_PZ_GW04	15/10/2020	0.0296
Nitrite-Nitrogen	mg/L	DG_A_I_PZ_GW07	2/07/2020	0.001
Nitrite-Nitrogen	mg/L	DG_A_I_PZ_GW03	2/07/2020	0.012
Nitrite-Nitrogen	mg/L	DG_A_I_PZ_GW02	2/07/2020	0.025
Nitrite-Nitrogen	mg/L	DG_A_I_PZ_GW08	6/07/2020	0.001
Nitrite-Nitrogen	mg/L	DG_A_I_PZ_WRK302	6/07/2020	0.001
Nitrite-Nitrogen	mg/L	DG_A_I_PZ_GW06	6/07/2020	0.001
Nitrite-Nitrogen	mg/L	DG_A_I_PZ_BW36A	7/07/2020	0.007
Nitrite-Nitrogen	mg/L	DG_A_I_PZ_GW01	7/07/2020	0.001
Nitrite-Nitrogen	mg/L	DG_A_I_PZ_BW45B	7/07/2020	0.008
Nitrite-Nitrogen	mg/L	DG_A_I_PZ_IWB2	8/07/2020	0.002
Nitrite-Nitrogen	mg/L	DG_A_I_PZ_IWB6	8/07/2020	0.004
Nitrite-Nitrogen	mg/L	DG_A_I_PZ_BW05	8/07/2020	0.001
Nitrite-Nitrogen	mg/L	DG_A_I_PZ_BW28A	8/07/2020	0.013
Nitrite-Nitrogen	mg/L	DG_A_I_PZ_BW53/Puls	9/07/2020	0.008
Nitrite-Nitrogen	mg/L	DG_A_I_PZ_GW05	9/07/2020	0.098
Nitrite-Nitrogen	mg/L	DG_A_I_PZ_GW04	9/07/2020	0.013
Nitrite-Nitrogen	mg/L	DG_A_I_PZ_WRK300	13/07/2020	0.052
Nitrite-Nitrogen	mg/L	DG_A_I_PZ_WRK303	13/07/2020	0.001
Nitrite-Nitrogen	mg/L	DG_A_I_PZ_WRK301	13/07/2020	0.002

Variable	Unit	Sample Point	Date	Result
Nitrite-Nitrogen	mg/L	DG_A_I_PZ_WRK304	14/07/2020	0.001
Nitrite-Nitrogen	mg/L	DG_A_I_PZ_GW04	10/08/2020	0.014
Nitrite-Nitrogen	mg/L	DG_A_I_PZ_BW28A	10/08/2020	0.006
Nitrite-Nitrogen	mg/L	DG_A_I_PZ_GW02	10/08/2020	0.029
Nitrite-Nitrogen	mg/L	DG_A_I_PZ_GW01	10/08/2020	0.004
Nitrite-Nitrogen	mg/L	DG_A_I_PZ_BW36A	17/08/2020	0.005
Nitrite-Nitrogen	mg/L	DG_A_I_PZ_BW53/Puls	17/08/2020	0.045
Nitrite-Nitrogen	mg/L	DG_A_I_PZ_GW05	17/08/2020	0.096
Nitrite-Nitrogen	mg/L	DG_A_I_PZ_WRK303	19/08/2020	0.001
Nitrite-Nitrogen	mg/L	DG_A_I_PZ_BW45B	19/08/2020	0.017
Nitrite-Nitrogen	mg/L	DG_A_I_PZ_WRK304	19/08/2020	0.002
Nitrite-Nitrogen	mg/L	DG_A_I_PZ_WRK302	3/09/2020	0.001
Nitrite-Nitrogen	mg/L	DG_A_I_PZ_GW04	15/10/2020	0.009
Nitrite-Nitrogen	mg/L	DG_A_I_PZ_GW04A	30/11/2020	0.12
Nitrite-Nitrogen	mg/L	DG_A_I_PZ_GW04A	30/12/2020	0.12
pH	pH units	DG_A_I_PZ_GW07	2/07/2020	6.4
pH	pH units	DG_A_I_PZ_GW07	2/07/2020	6.37
pH	pH units	DG_A_I_PZ_GW03	2/07/2020	6.4
pH	pH units	DG_A_I_PZ_GW03	2/07/2020	6.13
pH	pH units	DG_A_I_PZ_GW02	2/07/2020	5.6
pH	pH units	DG_A_I_PZ_GW02	2/07/2020	5.46
pH	pH units	DG_A_I_PZ_GW08	6/07/2020	6.4
pH	pH units	DG_A_I_PZ_GW08	6/07/2020	6.27
pH	pH units	DG_A_I_PZ_WRK302	6/07/2020	6.1
pH	pH units	DG_A_I_PZ_WRK302	6/07/2020	5.98
pH	pH units	DG_A_I_PZ_GW06	6/07/2020	6.7
pH	pH units	DG_A_I_PZ_GW06	6/07/2020	6.56
pH	pH units	DG_A_I_PZ_BW36A	7/07/2020	6.8
pH	pH units	DG_A_I_PZ_BW36A	7/07/2020	6.78
pH	pH units	DG_A_I_PZ_GW01	7/07/2020	5.5
pH	pH units	DG_A_I_PZ_GW01	7/07/2020	5.35
pH	pH units	DG_A_I_PZ_BW45B	7/07/2020	4.4
pH	pH units	DG_A_I_PZ_BW45B	7/07/2020	4.43
pH	pH units	DG_A_I_PZ_IWB2	8/07/2020	5.6
pH	pH units	DG_A_I_PZ_IWB2	8/07/2020	5.43
pH	pH units	DG_A_I_PZ_IWB6	8/07/2020	5.19
pH	pH units	DG_A_I_PZ_IWB6	8/07/2020	5.5
pH	pH units	DG_A_I_PZ_BW05	8/07/2020	7.2
pH	pH units	DG_A_I_PZ_BW05	8/07/2020	7
pH	pH units	DG_A_I_PZ_BW28A	8/07/2020	6.5
pH	pH units	DG_A_I_PZ_BW28A	8/07/2020	6.55
pH	pH units	DG_A_I_PZ_BW53/Puls	9/07/2020	6.9
pH	pH units	DG_A_I_PZ_BW53/Puls	9/07/2020	6.86
pH	pH units	DG_A_I_PZ_GW05	9/07/2020	6

Variable	Unit	Sample Point	Date	Result
pH	pH units	DG_A_I_PZ_GW05	9/07/2020	6
pH	pH units	DG_A_I_PZ_GW04	9/07/2020	5.8
pH	pH units	DG_A_I_PZ_GW04	9/07/2020	5.66
pH	pH units	DG_A_I_PZ_WRK300	13/07/2020	7
pH	pH units	DG_A_I_PZ_WRK300	13/07/2020	6.75
pH	pH units	DG_A_I_PZ_WRK303	13/07/2020	6.4
pH	pH units	DG_A_I_PZ_WRK303	13/07/2020	6.04
pH	pH units	DG_A_I_PZ_WRK301	13/07/2020	7.3
pH	pH units	DG_A_I_PZ_WRK301	13/07/2020	7.04
pH	pH units	DG_A_I_PZ_WRK304	14/07/2020	6.2
pH	pH units	DG_A_I_PZ_WRK304	14/07/2020	6.11
pH	pH units	DG_A_I_PZ_GW04	10/08/2020	5.6
pH	pH units	DG_A_I_PZ_BW28A	10/08/2020	6.6
pH	pH units	DG_A_I_PZ_BW28A	10/08/2020	6.58
pH	pH units	DG_A_I_PZ_GW02	10/08/2020	5.6
pH	pH units	DG_A_I_PZ_GW02	10/08/2020	5.51
pH	pH units	DG_A_I_PZ_GW01	10/08/2020	5.4
pH	pH units	DG_A_I_PZ_GW01	10/08/2020	5.55
pH	pH units	DG_A_I_PZ_GW04	10/08/2020	5.67
pH	pH units	DG_A_I_PZ_BW36A	17/08/2020	6.7
pH	pH units	DG_A_I_PZ_BW53/Puls	17/08/2020	6.7
pH	pH units	DG_A_I_PZ_BW53/Puls	17/08/2020	6.42
pH	pH units	DG_A_I_PZ_GW05	17/08/2020	6
pH	pH units	DG_A_I_PZ_GW05	17/08/2020	6.03
pH	pH units	DG_A_I_PZ_BW36A	17/08/2020	6.77
pH	pH units	DG_A_I_PZ_WRK303	19/08/2020	6
pH	pH units	DG_A_I_PZ_WRK303	19/08/2020	5.83
pH	pH units	DG_A_I_PZ_BW45B	19/08/2020	4.8
pH	pH units	DG_A_I_PZ_WRK304	19/08/2020	6.2
pH	pH units	DG_A_I_PZ_WRK304	19/08/2020	6.06
pH	pH units	DG_A_I_PZ_BW45B	19/08/2020	4.77
pH	pH units	DG_A_I_PZ_GW07	20/08/2020	6.27
pH	pH units	DG_A_I_PZ_GW03	20/08/2020	6.12
pH	pH units	DG_A_I_PZ_WRK300	20/08/2020	6.65
pH	pH units	DG_A_I_PZ_GW06	25/08/2020	6.53
pH	pH units	DG_A_I_PZ_GW08	25/08/2020	6.23
pH	pH units	DG_A_I_PZ_WRK302	25/08/2020	5.92
pH	pH units	DG_A_I_PZ_WRK301	25/08/2020	7
pH	pH units	DG_A_I_PZ_WRK302	3/09/2020	6
pH	pH units	DG_A_I_PZ_WRK302	3/09/2020	5.93
pH	pH units	DG_A_I_PZ_GW03	3/09/2020	6.11
pH	pH units	DG_A_I_PZ_GW02	3/09/2020	5.47
pH	pH units	DG_A_I_PZ_GW07	7/09/2020	6.36
pH	pH units	DG_A_I_PZ_GW05	7/09/2020	5.96

Variable	Unit	Sample Point	Date	Result
pH	pH units	DG_A_I_PZ_GW04	7/09/2020	5.69
pH	pH units	DG_A_I_PZ_BW36A	7/09/2020	6.65
pH	pH units	DG_A_I_PZ_GW01	7/09/2020	5.38
pH	pH units	DG_A_I_PZ_BW45B	7/09/2020	4.49
pH	pH units	DG_A_I_PZ_GW08	8/09/2020	6.25
pH	pH units	DG_A_I_PZ_GW06	8/09/2020	6.56
pH	pH units	DG_A_I_PZ_WRK300	8/09/2020	6.65
pH	pH units	DG_A_I_PZ_WRK304	9/09/2020	6.17
pH	pH units	DG_A_I_PZ_WRK303	9/09/2020	6.07
pH	pH units	DG_A_I_PZ_WRK301	9/09/2020	7.03
pH	pH units	DG_A_I_PZ_GW04	15/10/2020	6
pH	pH units	DG_A_I_PZ_GW04	15/10/2020	5.72
pH	pH units	DG_A_I_PZ_GW03	15/10/2020	6.23
pH	pH units	DG_A_I_PZ_GW02	15/10/2020	5.54
pH	pH units	DG_A_I_PZ_GW07	16/10/2020	6.37
pH	pH units	DG_A_I_PZ_GW01	16/10/2020	5.48
pH	pH units	DG_A_I_PZ_BW45B	16/10/2020	4.4
pH	pH units	DG_A_I_PZ_GW05	19/10/2020	5.94
pH	pH units	DG_A_I_PZ_BW36A	19/10/2020	6.67
pH	pH units	DG_A_I_PZ_WRK300	19/10/2020	6.53
pH	pH units	DG_A_I_PZ_GW08	19/10/2020	6.26
pH	pH units	DG_A_I_PZ_WRK302	19/10/2020	5.96
pH	pH units	DG_A_I_PZ_GW06	19/10/2020	6.55
pH	pH units	DG_A_I_PZ_WRK304	20/10/2020	6.14
pH	pH units	DG_A_I_PZ_WRK303	20/10/2020	5.92
pH	pH units	DG_A_I_PZ_WRK301	20/10/2020	7.04
pH	pH units	DG_A_I_PZ_GW07	24/11/2020	6.31
pH	pH units	DG_A_I_PZ_GW03	24/11/2020	6.06
pH	pH units	DG_A_I_PZ_GW02	24/11/2020	5.42
pH	pH units	DG_A_I_PZ_GW01	24/11/2020	5.32
pH	pH units	DG_A_I_PZ_BW45B	24/11/2020	4.24
pH	pH units	DG_A_I_PZ_GW04	25/11/2020	5.52
pH	pH units	DG_A_I_PZ_GW05	25/11/2020	5.86
pH	pH units	DG_A_I_PZ_BW36A	25/11/2020	6.5
pH	pH units	DG_A_I_PZ_WRK300	25/11/2020	6.53
pH	pH units	DG_A_I_PZ_GW08	26/11/2020	6.17
pH	pH units	DG_A_I_PZ_WRK302	26/11/2020	5.88
pH	pH units	DG_A_I_PZ_GW06	26/11/2020	6.45
pH	pH units	DG_A_I_PZ_GW04A	30/11/2020	6.6
pH	pH units	DG_A_I_PZ_GW04A	30/11/2020	6.42
pH	pH units	DG_A_I_PZ_WRK304	30/11/2020	6.02
pH	pH units	DG_A_I_PZ_WRK303	30/11/2020	5.9
pH	pH units	DG_A_I_PZ_WRK301	30/11/2020	6.82
pH	pH units	DG_A_I_PZ_GW05	4/12/2020	5.87

Variable	Unit	Sample Point	Date	Result
pH	pH units	DG_A_I_PZ_GW07	8/12/2020	6.31
pH	pH units	DG_A_I_PZ_GW03	8/12/2020	6.05
pH	pH units	DG_A_I_PZ_GW02	8/12/2020	5.37
pH	pH units	DG_A_I_PZ_BW45B	9/12/2020	4.3
pH	pH units	DG_A_I_PZ_GW01	9/12/2020	5.26
pH	pH units	DG_A_I_PZ_GW04	9/12/2020	5.53
pH	pH units	DG_A_I_PZ_BW36A	9/12/2020	6.55
pH	pH units	DG_A_I_PZ_GW04A	10/12/2020	6.17
pH	pH units	DG_A_I_PZ_GW08	10/12/2020	6.25
pH	pH units	DG_A_I_PZ_WRK302	10/12/2020	5.98
pH	pH units	DG_A_I_PZ_GW06	10/12/2020	6.59
pH	pH units	DG_A_I_PZ_WRK304	14/12/2020	5.91
pH	pH units	DG_A_I_PZ_WRK303	14/12/2020	5.76
pH	pH units	DG_A_I_PZ_WRK301	14/12/2020	6.84
pH	pH units	DG_A_I_PZ_WRK300	14/12/2020	6.28
pH	pH units	DG_A_I_PZ_GW04A	30/12/2020	6.6
Phosphorus (Ortho)	mg/L	DG_A_I_PZ_GW07	2/07/2020	0.004
Phosphorus (Ortho)	mg/L	DG_A_I_PZ_GW03	2/07/2020	0.004
Phosphorus (Ortho)	mg/L	DG_A_I_PZ_GW02	2/07/2020	0.004
Phosphorus (Ortho)	mg/L	DG_A_I_PZ_GW08	6/07/2020	0.004
Phosphorus (Ortho)	mg/L	DG_A_I_PZ_WRK302	6/07/2020	0.004
Phosphorus (Ortho)	mg/L	DG_A_I_PZ_GW06	6/07/2020	0.009
Phosphorus (Ortho)	mg/L	DG_A_I_PZ_BW36A	7/07/2020	0.058
Phosphorus (Ortho)	mg/L	DG_A_I_PZ_GW01	7/07/2020	0.004
Phosphorus (Ortho)	mg/L	DG_A_I_PZ_BW45B	7/07/2020	0.004
Phosphorus (Ortho)	mg/L	DG_A_I_PZ_IWB2	8/07/2020	0.077
Phosphorus (Ortho)	mg/L	DG_A_I_PZ_IWB6	8/07/2020	0.004
Phosphorus (Ortho)	mg/L	DG_A_I_PZ_BW05	8/07/2020	0.004
Phosphorus (Ortho)	mg/L	DG_A_I_PZ_BW28A	8/07/2020	0.063
Phosphorus (Ortho)	mg/L	DG_A_I_PZ_BW53/Puls	9/07/2020	0.96
Phosphorus (Ortho)	mg/L	DG_A_I_PZ_GW05	9/07/2020	0.006
Phosphorus (Ortho)	mg/L	DG_A_I_PZ_GW04	9/07/2020	0.004
Phosphorus (Ortho)	mg/L	DG_A_I_PZ_WRK300	13/07/2020	0.004
Phosphorus (Ortho)	mg/L	DG_A_I_PZ_WRK303	13/07/2020	0.006
Phosphorus (Ortho)	mg/L	DG_A_I_PZ_WRK301	13/07/2020	0.007
Phosphorus (Ortho)	mg/L	DG_A_I_PZ_WRK304	14/07/2020	0.014
Phosphorus (Ortho)	mg/L	DG_A_I_PZ_GW04	10/08/2020	0.008
Phosphorus (Ortho)	mg/L	DG_A_I_PZ_BW28A	10/08/2020	0.047
Phosphorus (Ortho)	mg/L	DG_A_I_PZ_GW02	10/08/2020	0.004
Phosphorus (Ortho)	mg/L	DG_A_I_PZ_GW01	10/08/2020	0.004
Phosphorus (Ortho)	mg/L	DG_A_I_PZ_BW36A	17/08/2020	0.043
Phosphorus (Ortho)	mg/L	DG_A_I_PZ_BW53/Puls	17/08/2020	0.28
Phosphorus (Ortho)	mg/L	DG_A_I_PZ_GW05	17/08/2020	0.005
Phosphorus (Ortho)	mg/L	DG_A_I_PZ_WRK303	19/08/2020	0.009

Variable	Unit	Sample Point	Date	Result
Phosphorus (Ortho)	mg/L	DG_A_I_PZ_BW45B	19/08/2020	0.004
Phosphorus (Ortho)	mg/L	DG_A_I_PZ_WRK304	19/08/2020	0.016
Phosphorus (Ortho)	mg/L	DG_A_I_PZ_WRK302	3/09/2020	0.004
Phosphorus (Ortho)	mg/L	DG_A_I_PZ_GW04	15/10/2020	0.011
Phosphorus (Ortho)	mg/L	DG_A_I_PZ_GW04A	30/11/2020	0.004
Phosphorus (Ortho)	mg/L	DG_A_I_PZ_GW04A	30/12/2020	0.004
Potassium	mg/L	DG_A_I_PZ_GW07	2/07/2020	16
Potassium	mg/L	DG_A_I_PZ_GW03	2/07/2020	29
Potassium	mg/L	DG_A_I_PZ_GW02	2/07/2020	26
Potassium	mg/L	DG_A_I_PZ_GW08	6/07/2020	19
Potassium	mg/L	DG_A_I_PZ_WRK302	6/07/2020	26
Potassium	mg/L	DG_A_I_PZ_GW06	6/07/2020	21
Potassium	mg/L	DG_A_I_PZ_BW36A	7/07/2020	15
Potassium	mg/L	DG_A_I_PZ_GW01	7/07/2020	17
Potassium	mg/L	DG_A_I_PZ_BW45B	7/07/2020	19
Potassium	mg/L	DG_A_I_PZ_IWB2	8/07/2020	5
Potassium	mg/L	DG_A_I_PZ_IWB6	8/07/2020	1.5
Potassium	mg/L	DG_A_I_PZ_BW05	8/07/2020	81
Potassium	mg/L	DG_A_I_PZ_BW28A	8/07/2020	43
Potassium	mg/L	DG_A_I_PZ_BW53/Puls	9/07/2020	9.8
Potassium	mg/L	DG_A_I_PZ_GW05	9/07/2020	16
Potassium	mg/L	DG_A_I_PZ_GW04	9/07/2020	15
Potassium	mg/L	DG_A_I_PZ_WRK300	13/07/2020	14
Potassium	mg/L	DG_A_I_PZ_WRK303	13/07/2020	15
Potassium	mg/L	DG_A_I_PZ_WRK301	13/07/2020	25
Potassium	mg/L	DG_A_I_PZ_WRK304	14/07/2020	22
Potassium	mg/L	DG_A_I_PZ_GW04	10/08/2020	16
Potassium	mg/L	DG_A_I_PZ_BW28A	10/08/2020	42
Potassium	mg/L	DG_A_I_PZ_GW02	10/08/2020	26
Potassium	mg/L	DG_A_I_PZ_GW01	10/08/2020	17
Potassium	mg/L	DG_A_I_PZ_BW36A	17/08/2020	15
Potassium	mg/L	DG_A_I_PZ_BW53/Puls	17/08/2020	9.8
Potassium	mg/L	DG_A_I_PZ_GW05	17/08/2020	14
Potassium	mg/L	DG_A_I_PZ_WRK303	19/08/2020	13
Potassium	mg/L	DG_A_I_PZ_BW45B	19/08/2020	18
Potassium	mg/L	DG_A_I_PZ_WRK304	19/08/2020	20
Potassium	mg/L	DG_A_I_PZ_WRK302	3/09/2020	24
Potassium	mg/L	DG_A_I_PZ_GW04	15/10/2020	16
Potassium	mg/L	DG_A_I_PZ_GW04A	30/11/2020	13
Potassium	mg/L	DG_A_I_PZ_GW04A	30/12/2020	13
Radium 226	Bq/L	DG_A_I_PZ_GW07	2/07/2020	0.07
Radium 226	Bq/L	DG_A_I_PZ_GW03	2/07/2020	0.01
Radium 226	Bq/L	DG_A_I_PZ_GW02	2/07/2020	0.1
Radium 226	Bq/L	DG_A_I_PZ_GW08	6/07/2020	0.06

Variable	Unit	Sample Point	Date	Result
Radium 226	Bq/L	DG_A_I_PZ_WRK302	6/07/2020	0.18
Radium 226	Bq/L	DG_A_I_PZ_GW06	6/07/2020	0.05
Radium 226	Bq/L	DG_A_I_PZ_BW36A	7/07/2020	0.06
Radium 226	Bq/L	DG_A_I_PZ_GW01	7/07/2020	0.24
Radium 226	Bq/L	DG_A_I_PZ_BW45B	7/07/2020	0.69
Radium 226	Bq/L	DG_A_I_PZ_IWB2	8/07/2020	0.01
Radium 226	Bq/L	DG_A_I_PZ_IWB6	8/07/2020	0.02
Radium 226	Bq/L	DG_A_I_PZ_BW05	8/07/2020	0.03
Radium 226	Bq/L	DG_A_I_PZ_BW28A	8/07/2020	0.11
Radium 226	Bq/L	DG_A_I_PZ_BW53/Puls	9/07/2020	0.04
Radium 226	Bq/L	DG_A_I_PZ_GW05	9/07/2020	0.04
Radium 226	Bq/L	DG_A_I_PZ_GW04	9/07/2020	0.12
Radium 226	Bq/L	DG_A_I_PZ_WRK300	13/07/2020	0.03
Radium 226	Bq/L	DG_A_I_PZ_WRK303	13/07/2020	0.04
Radium 226	Bq/L	DG_A_I_PZ_WRK301	13/07/2020	0.01
Radium 226	Bq/L	DG_A_I_PZ_WRK304	14/07/2020	0.02
Radium 226	Bq/L	DG_A_I_PZ_BW28A	10/08/2020	0.11
Radium 226	Bq/L	DG_A_I_PZ_GW02	10/08/2020	0.09
Radium 226	Bq/L	DG_A_I_PZ_GW01	10/08/2020	0.13
Radium 226	Bq/L	DG_A_I_PZ_GW04	10/08/2020	0.12
Radium 226	Bq/L	DG_A_I_PZ_BW53/Puls	17/08/2020	0.03
Radium 226	Bq/L	DG_A_I_PZ_GW05	17/08/2020	0.07
Radium 226	Bq/L	DG_A_I_PZ_BW36A	17/08/2020	0.06
Radium 226	Bq/L	DG_A_I_PZ_WRK303	19/08/2020	0.03
Radium 226	Bq/L	DG_A_I_PZ_WRK304	19/08/2020	0.01
Radium 226	Bq/L	DG_A_I_PZ_BW45B	19/08/2020	0.58
Radium 226	Bq/L	DG_A_I_PZ_WRK302	3/09/2020	0.33
Radium 226	Bq/L	DG_A_I_PZ_GW04	15/10/2020	0.12
Radium 226	Bq/L	DG_A_I_PZ_GW04A	30/11/2020	0.04
Radium 228	Bq/L	DG_A_I_PZ_GW07	2/07/2020	0.34
Radium 228	Bq/L	DG_A_I_PZ_GW03	2/07/2020	0.08
Radium 228	Bq/L	DG_A_I_PZ_GW02	2/07/2020	0.33
Radium 228	Bq/L	DG_A_I_PZ_GW08	6/07/2020	0.08
Radium 228	Bq/L	DG_A_I_PZ_WRK302	6/07/2020	0.74
Radium 228	Bq/L	DG_A_I_PZ_GW06	6/07/2020	0.19
Radium 228	Bq/L	DG_A_I_PZ_BW36A	7/07/2020	0.15
Radium 228	Bq/L	DG_A_I_PZ_GW01	7/07/2020	0.72
Radium 228	Bq/L	DG_A_I_PZ_BW45B	7/07/2020	3.02
Radium 228	Bq/L	DG_A_I_PZ_IWB2	8/07/2020	0.08
Radium 228	Bq/L	DG_A_I_PZ_IWB6	8/07/2020	0.08
Radium 228	Bq/L	DG_A_I_PZ_BW05	8/07/2020	0.08
Radium 228	Bq/L	DG_A_I_PZ_BW28A	8/07/2020	0.08
Radium 228	Bq/L	DG_A_I_PZ_BW53/Puls	9/07/2020	0.1
Radium 228	Bq/L	DG_A_I_PZ_GW05	9/07/2020	0.11

Variable	Unit	Sample Point	Date	Result
Radium 228	Bq/L	DG_A_I_PZ_GW04	9/07/2020	0.24
Radium 228	Bq/L	DG_A_I_PZ_WRK300	13/07/2020	0.08
Radium 228	Bq/L	DG_A_I_PZ_WRK303	13/07/2020	0.09
Radium 228	Bq/L	DG_A_I_PZ_WRK301	13/07/2020	0.08
Radium 228	Bq/L	DG_A_I_PZ_WRK304	14/07/2020	0.08
Radium 228	Bq/L	DG_A_I_PZ_BW28A	10/08/2020	0.08
Radium 228	Bq/L	DG_A_I_PZ_GW02	10/08/2020	0.31
Radium 228	Bq/L	DG_A_I_PZ_GW01	10/08/2020	0.42
Radium 228	Bq/L	DG_A_I_PZ_GW04	10/08/2020	0.25
Radium 228	Bq/L	DG_A_I_PZ_BW53/Puls	17/08/2020	0.1
Radium 228	Bq/L	DG_A_I_PZ_GW05	17/08/2020	0.16
Radium 228	Bq/L	DG_A_I_PZ_BW36A	17/08/2020	0.2
Radium 228	Bq/L	DG_A_I_PZ_WRK303	19/08/2020	0.08
Radium 228	Bq/L	DG_A_I_PZ_WRK304	19/08/2020	0.08
Radium 228	Bq/L	DG_A_I_PZ_BW45B	19/08/2020	2.36
Radium 228	Bq/L	DG_A_I_PZ_WRK302	3/09/2020	0.91
Radium 228	Bq/L	DG_A_I_PZ_GW04	15/10/2020	0.25
Radium 228	Bq/L	DG_A_I_PZ_GW04A	30/11/2020	0.2
Redox Potential (Eh)	mV	DG_A_I_PZ_GW07	2/07/2020	210
Redox Potential (Eh)	mV	DG_A_I_PZ_GW03	2/07/2020	35
Redox Potential (Eh)	mV	DG_A_I_PZ_GW02	2/07/2020	234
Redox Potential (Eh)	mV	DG_A_I_PZ_GW08	6/07/2020	173
Redox Potential (Eh)	mV	DG_A_I_PZ_WRK302	6/07/2020	182
Redox Potential (Eh)	mV	DG_A_I_PZ_GW06	6/07/2020	164
Redox Potential (Eh)	mV	DG_A_I_PZ_BW36A	7/07/2020	-41
Redox Potential (Eh)	mV	DG_A_I_PZ_GW01	7/07/2020	228
Redox Potential (Eh)	mV	DG_A_I_PZ_BW45B	7/07/2020	283
Redox Potential (Eh)	mV	DG_A_I_PZ_IWB2	8/07/2020	315
Redox Potential (Eh)	mV	DG_A_I_PZ_IWB6	8/07/2020	346
Redox Potential (Eh)	mV	DG_A_I_PZ_BW05	8/07/2020	-10
Redox Potential (Eh)	mV	DG_A_I_PZ_BW28A	8/07/2020	-16
Redox Potential (Eh)	mV	DG_A_I_PZ_BW53/Puls	9/07/2020	-130
Redox Potential (Eh)	mV	DG_A_I_PZ_GW05	9/07/2020	134
Redox Potential (Eh)	mV	DG_A_I_PZ_GW04	9/07/2020	156
Redox Potential (Eh)	mV	DG_A_I_PZ_WRK300	13/07/2020	138
Redox Potential (Eh)	mV	DG_A_I_PZ_WRK303	13/07/2020	209
Redox Potential (Eh)	mV	DG_A_I_PZ_WRK301	13/07/2020	147
Redox Potential (Eh)	mV	DG_A_I_PZ_WRK304	14/07/2020	221
Redox Potential (Eh)	mV	DG_A_I_PZ_BW28A	10/08/2020	-10
Redox Potential (Eh)	mV	DG_A_I_PZ_GW02	10/08/2020	309
Redox Potential (Eh)	mV	DG_A_I_PZ_GW01	10/08/2020	489
Redox Potential (Eh)	mV	DG_A_I_PZ_GW04	10/08/2020	380
Redox Potential (Eh)	mV	DG_A_I_PZ_BW53/Puls	17/08/2020	-6
Redox Potential (Eh)	mV	DG_A_I_PZ_GW05	17/08/2020	384

Variable	Unit	Sample Point	Date	Result
Redox Potential (Eh)	mV	DG_A_I_PZ_BW36A	17/08/2020	9
Redox Potential (Eh)	mV	DG_A_I_PZ_WRK303	19/08/2020	244
Redox Potential (Eh)	mV	DG_A_I_PZ_WRK304	19/08/2020	215
Redox Potential (Eh)	mV	DG_A_I_PZ_BW45B	19/08/2020	273
Redox Potential (Eh)	mV	DG_A_I_PZ_GW07	20/08/2020	222
Redox Potential (Eh)	mV	DG_A_I_PZ_GW03	20/08/2020	71
Redox Potential (Eh)	mV	DG_A_I_PZ_WRK300	20/08/2020	139
Redox Potential (Eh)	mV	DG_A_I_PZ_GW06	25/08/2020	165
Redox Potential (Eh)	mV	DG_A_I_PZ_GW08	25/08/2020	191
Redox Potential (Eh)	mV	DG_A_I_PZ_WRK302	25/08/2020	185
Redox Potential (Eh)	mV	DG_A_I_PZ_WRK301	25/08/2020	86
Redox Potential (Eh)	mV	DG_A_I_PZ_WRK302	3/09/2020	235
Redox Potential (Eh)	mV	DG_A_I_PZ_GW03	3/09/2020	115
Redox Potential (Eh)	mV	DG_A_I_PZ_GW02	3/09/2020	315
Redox Potential (Eh)	mV	DG_A_I_PZ_GW07	7/09/2020	252
Redox Potential (Eh)	mV	DG_A_I_PZ_GW05	7/09/2020	302
Redox Potential (Eh)	mV	DG_A_I_PZ_GW04	7/09/2020	340
Redox Potential (Eh)	mV	DG_A_I_PZ_BW36A	7/09/2020	-72
Redox Potential (Eh)	mV	DG_A_I_PZ_GW01	7/09/2020	172
Redox Potential (Eh)	mV	DG_A_I_PZ_BW45B	7/09/2020	234
Redox Potential (Eh)	mV	DG_A_I_PZ_GW08	8/09/2020	235
Redox Potential (Eh)	mV	DG_A_I_PZ_GW06	8/09/2020	252
Redox Potential (Eh)	mV	DG_A_I_PZ_WRK300	8/09/2020	229
Redox Potential (Eh)	mV	DG_A_I_PZ_WRK304	9/09/2020	547
Redox Potential (Eh)	mV	DG_A_I_PZ_WRK303	9/09/2020	200
Redox Potential (Eh)	mV	DG_A_I_PZ_WRK301	9/09/2020	261
Redox Potential (Eh)	mV	DG_A_I_PZ_GW04	15/10/2020	279
Redox Potential (Eh)	mV	DG_A_I_PZ_GW03	15/10/2020	88
Redox Potential (Eh)	mV	DG_A_I_PZ_GW02	15/10/2020	286
Redox Potential (Eh)	mV	DG_A_I_PZ_GW07	16/10/2020	210
Redox Potential (Eh)	mV	DG_A_I_PZ_GW01	16/10/2020	261
Redox Potential (Eh)	mV	DG_A_I_PZ_BW45B	16/10/2020	310
Redox Potential (Eh)	mV	DG_A_I_PZ_GW05	19/10/2020	222
Redox Potential (Eh)	mV	DG_A_I_PZ_BW36A	19/10/2020	-66
Redox Potential (Eh)	mV	DG_A_I_PZ_WRK300	19/10/2020	162
Redox Potential (Eh)	mV	DG_A_I_PZ_GW08	19/10/2020	215
Redox Potential (Eh)	mV	DG_A_I_PZ_WRK302	19/10/2020	240
Redox Potential (Eh)	mV	DG_A_I_PZ_GW06	19/10/2020	218
Redox Potential (Eh)	mV	DG_A_I_PZ_WRK304	20/10/2020	212
Redox Potential (Eh)	mV	DG_A_I_PZ_WRK303	20/10/2020	210
Redox Potential (Eh)	mV	DG_A_I_PZ_WRK301	20/10/2020	90
Redox Potential (Eh)	mV	DG_A_I_PZ_GW07	24/11/2020	155
Redox Potential (Eh)	mV	DG_A_I_PZ_GW03	24/11/2020	63
Redox Potential (Eh)	mV	DG_A_I_PZ_GW02	24/11/2020	177

Variable	Unit	Sample Point	Date	Result
Redox Potential (Eh)	mV	DG_A_I_PZ_GW01	24/11/2020	199
Redox Potential (Eh)	mV	DG_A_I_PZ_BW45B	24/11/2020	286
Redox Potential (Eh)	mV	DG_A_I_PZ_GW04	25/11/2020	293
Redox Potential (Eh)	mV	DG_A_I_PZ_GW05	25/11/2020	260
Redox Potential (Eh)	mV	DG_A_I_PZ_BW36A	25/11/2020	-100
Redox Potential (Eh)	mV	DG_A_I_PZ_WRK300	25/11/2020	101
Redox Potential (Eh)	mV	DG_A_I_PZ_GW08	26/11/2020	203
Redox Potential (Eh)	mV	DG_A_I_PZ_WRK302	26/11/2020	236
Redox Potential (Eh)	mV	DG_A_I_PZ_GW06	26/11/2020	284
Redox Potential (Eh)	mV	DG_A_I_PZ_GW04A	30/11/2020	647
Redox Potential (Eh)	mV	DG_A_I_PZ_WRK304	30/11/2020	200
Redox Potential (Eh)	mV	DG_A_I_PZ_WRK303	30/11/2020	220
Redox Potential (Eh)	mV	DG_A_I_PZ_WRK301	30/11/2020	91
Redox Potential (Eh)	mV	DG_A_I_PZ_GW05	4/12/2020	190
Redox Potential (Eh)	mV	DG_A_I_PZ_GW07	8/12/2020	191
Redox Potential (Eh)	mV	DG_A_I_PZ_GW03	8/12/2020	107
Redox Potential (Eh)	mV	DG_A_I_PZ_GW02	8/12/2020	135
Redox Potential (Eh)	mV	DG_A_I_PZ_BW45B	9/12/2020	240
Redox Potential (Eh)	mV	DG_A_I_PZ_GW01	9/12/2020	216
Redox Potential (Eh)	mV	DG_A_I_PZ_GW04	9/12/2020	202
Redox Potential (Eh)	mV	DG_A_I_PZ_BW36A	9/12/2020	-54
Redox Potential (Eh)	mV	DG_A_I_PZ_GW04A	10/12/2020	160
Redox Potential (Eh)	mV	DG_A_I_PZ_GW08	10/12/2020	185
Redox Potential (Eh)	mV	DG_A_I_PZ_WRK302	10/12/2020	191
Redox Potential (Eh)	mV	DG_A_I_PZ_GW06	10/12/2020	184
Redox Potential (Eh)	mV	DG_A_I_PZ_WRK304	14/12/2020	186
Redox Potential (Eh)	mV	DG_A_I_PZ_WRK303	14/12/2020	169
Redox Potential (Eh)	mV	DG_A_I_PZ_WRK301	14/12/2020	76
Redox Potential (Eh)	mV	DG_A_I_PZ_WRK300	14/12/2020	88
Selenium (Total)	mg/L	DG_A_I_PZ_GW07	2/07/2020	0.008
Selenium (Total)	mg/L	DG_A_I_PZ_GW03	2/07/2020	0.001
Selenium (Total)	mg/L	DG_A_I_PZ_GW02	2/07/2020	0.003
Selenium (Total)	mg/L	DG_A_I_PZ_GW08	6/07/2020	0.015
Selenium (Total)	mg/L	DG_A_I_PZ_WRK302	6/07/2020	0.011
Selenium (Total)	mg/L	DG_A_I_PZ_GW06	6/07/2020	0.007
Selenium (Total)	mg/L	DG_A_I_PZ_BW36A	7/07/2020	0.003
Selenium (Total)	mg/L	DG_A_I_PZ_GW01	7/07/2020	0.024
Selenium (Total)	mg/L	DG_A_I_PZ_BW45B	7/07/2020	0.022
Selenium (Total)	mg/L	DG_A_I_PZ_IWB2	8/07/2020	0.001
Selenium (Total)	mg/L	DG_A_I_PZ_IWB6	8/07/2020	0.002
Selenium (Total)	mg/L	DG_A_I_PZ_BW05	8/07/2020	0.015
Selenium (Total)	mg/L	DG_A_I_PZ_BW28A	8/07/2020	0.013
Selenium (Total)	mg/L	DG_A_I_PZ_BW53/Puls	9/07/2020	0.003
Selenium (Total)	mg/L	DG_A_I_PZ_GW05	9/07/2020	0.033

Variable	Unit	Sample Point	Date	Result
Selenium (Total)	mg/L	DG_A_I_PZ_GW04	9/07/2020	0.031
Selenium (Total)	mg/L	DG_A_I_PZ_WRK300	13/07/2020	0.002
Selenium (Total)	mg/L	DG_A_I_PZ_WRK303	13/07/2020	0.016
Selenium (Total)	mg/L	DG_A_I_PZ_WRK301	13/07/2020	0.007
Selenium (Total)	mg/L	DG_A_I_PZ_WRK304	14/07/2020	0.017
Selenium (Total)	mg/L	DG_A_I_PZ_GW04	10/08/2020	0.029
Selenium (Total)	mg/L	DG_A_I_PZ_BW28A	10/08/2020	0.014
Selenium (Total)	mg/L	DG_A_I_PZ_GW02	10/08/2020	0.004
Selenium (Total)	mg/L	DG_A_I_PZ_GW01	10/08/2020	0.033
Selenium (Total)	mg/L	DG_A_I_PZ_BW36A	17/08/2020	0.002
Selenium (Total)	mg/L	DG_A_I_PZ_BW53/Puls	17/08/2020	0.001
Selenium (Total)	mg/L	DG_A_I_PZ_GW05	17/08/2020	0.037
Selenium (Total)	mg/L	DG_A_I_PZ_WRK303	19/08/2020	0.028
Selenium (Total)	mg/L	DG_A_I_PZ_BW45B	19/08/2020	0.034
Selenium (Total)	mg/L	DG_A_I_PZ_WRK304	19/08/2020	0.013
Selenium (Total)	mg/L	DG_A_I_PZ_WRK302	3/09/2020	0.01
Selenium (Total)	mg/L	DG_A_I_PZ_GW04	15/10/2020	0.026
Selenium (Total)	mg/L	DG_A_I_PZ_GW04A	30/11/2020	0.011
Selenium (Total)	mg/L	DG_A_I_PZ_GW04A	30/12/2020	0.011
Silver (Total)	mg/L	DG_A_I_PZ_GW07	2/07/2020	0.001
Silver (Total)	mg/L	DG_A_I_PZ_GW03	2/07/2020	0.001
Silver (Total)	mg/L	DG_A_I_PZ_GW02	2/07/2020	0.001
Silver (Total)	mg/L	DG_A_I_PZ_GW08	6/07/2020	0.001
Silver (Total)	mg/L	DG_A_I_PZ_WRK302	6/07/2020	0.001
Silver (Total)	mg/L	DG_A_I_PZ_GW06	6/07/2020	0.001
Silver (Total)	mg/L	DG_A_I_PZ_BW36A	7/07/2020	0.001
Silver (Total)	mg/L	DG_A_I_PZ_GW01	7/07/2020	0.001
Silver (Total)	mg/L	DG_A_I_PZ_BW45B	7/07/2020	0.001
Silver (Total)	mg/L	DG_A_I_PZ_IWB2	8/07/2020	0.001
Silver (Total)	mg/L	DG_A_I_PZ_IWB6	8/07/2020	0.001
Silver (Total)	mg/L	DG_A_I_PZ_BW05	8/07/2020	0.001
Silver (Total)	mg/L	DG_A_I_PZ_BW28A	8/07/2020	0.001
Silver (Total)	mg/L	DG_A_I_PZ_BW53/Puls	9/07/2020	0.001
Silver (Total)	mg/L	DG_A_I_PZ_GW05	9/07/2020	0.001
Silver (Total)	mg/L	DG_A_I_PZ_GW04	9/07/2020	0.001
Silver (Total)	mg/L	DG_A_I_PZ_WRK300	13/07/2020	0.001
Silver (Total)	mg/L	DG_A_I_PZ_WRK303	13/07/2020	0.001
Silver (Total)	mg/L	DG_A_I_PZ_WRK301	13/07/2020	0.001
Silver (Total)	mg/L	DG_A_I_PZ_WRK304	14/07/2020	0.001
Silver (Total)	mg/L	DG_A_I_PZ_GW04	10/08/2020	0.001
Silver (Total)	mg/L	DG_A_I_PZ_BW28A	10/08/2020	0.001
Silver (Total)	mg/L	DG_A_I_PZ_GW02	10/08/2020	0.001
Silver (Total)	mg/L	DG_A_I_PZ_GW01	10/08/2020	0.001
Silver (Total)	mg/L	DG_A_I_PZ_BW36A	17/08/2020	0.001

Variable	Unit	Sample Point	Date	Result
Silver (Total)	mg/L	DG_A_I_PZ_BW53/Puls	17/08/2020	0.001
Silver (Total)	mg/L	DG_A_I_PZ_GW05	17/08/2020	0.001
Silver (Total)	mg/L	DG_A_I_PZ_WRK303	19/08/2020	0.001
Silver (Total)	mg/L	DG_A_I_PZ_BW45B	19/08/2020	0.001
Silver (Total)	mg/L	DG_A_I_PZ_WRK304	19/08/2020	0.001
Silver (Total)	mg/L	DG_A_I_PZ_WRK302	3/09/2020	0.001
Silver (Total)	mg/L	DG_A_I_PZ_GW04	15/10/2020	0.003
Silver (Total)	mg/L	DG_A_I_PZ_GW04A	30/11/2020	0.001
Silver (Total)	mg/L	DG_A_I_PZ_GW04A	30/12/2020	0.001
Sodium	mg/L	DG_A_I_PZ_GW07	2/07/2020	3100
Sodium	mg/L	DG_A_I_PZ_GW03	2/07/2020	1900
Sodium	mg/L	DG_A_I_PZ_GW02	2/07/2020	1200
Sodium	mg/L	DG_A_I_PZ_GW08	6/07/2020	3400
Sodium	mg/L	DG_A_I_PZ_WRK302	6/07/2020	3400
Sodium	mg/L	DG_A_I_PZ_GW06	6/07/2020	3500
Sodium	mg/L	DG_A_I_PZ_BW36A	7/07/2020	1200
Sodium	mg/L	DG_A_I_PZ_GW01	7/07/2020	2000
Sodium	mg/L	DG_A_I_PZ_BW45B	7/07/2020	2900
Sodium	mg/L	DG_A_I_PZ_IWB2	8/07/2020	610
Sodium	mg/L	DG_A_I_PZ_IWB6	8/07/2020	310
Sodium	mg/L	DG_A_I_PZ_BW05	8/07/2020	4700
Sodium	mg/L	DG_A_I_PZ_BW28A	8/07/2020	3500
Sodium	mg/L	DG_A_I_PZ_BW53/Puls	9/07/2020	490
Sodium	mg/L	DG_A_I_PZ_GW05	9/07/2020	1900
Sodium	mg/L	DG_A_I_PZ_GW04	9/07/2020	1700
Sodium	mg/L	DG_A_I_PZ_WRK300	13/07/2020	930
Sodium	mg/L	DG_A_I_PZ_WRK303	13/07/2020	1700
Sodium	mg/L	DG_A_I_PZ_WRK301	13/07/2020	1800
Sodium	mg/L	DG_A_I_PZ_WRK304	14/07/2020	1600
Sodium	mg/L	DG_A_I_PZ_GW04	10/08/2020	1600
Sodium	mg/L	DG_A_I_PZ_BW28A	10/08/2020	3200
Sodium	mg/L	DG_A_I_PZ_GW02	10/08/2020	1200
Sodium	mg/L	DG_A_I_PZ_GW01	10/08/2020	1800
Sodium	mg/L	DG_A_I_PZ_BW36A	17/08/2020	1300
Sodium	mg/L	DG_A_I_PZ_BW53/Puls	17/08/2020	460
Sodium	mg/L	DG_A_I_PZ_GW05	17/08/2020	1700
Sodium	mg/L	DG_A_I_PZ_WRK303	19/08/2020	1600
Sodium	mg/L	DG_A_I_PZ_BW45B	19/08/2020	2600
Sodium	mg/L	DG_A_I_PZ_WRK304	19/08/2020	1400
Sodium	mg/L	DG_A_I_PZ_WRK302	3/09/2020	3300
Sodium	mg/L	DG_A_I_PZ_GW04	15/10/2020	1600
Sodium	mg/L	DG_A_I_PZ_GW04A	30/11/2020	1300
Sodium	mg/L	DG_A_I_PZ_GW04A	30/12/2020	1300
Standing Water Level	mAHD	DG_A_I_PZ_GW07	2/07/2020	172.536

Variable	Unit	Sample Point	Date	Result
Standing Water Level	mAHD	DG_A_I_PZ_GW03	2/07/2020	162.02
Standing Water Level	mAHD	DG_A_I_PZ_GW02	2/07/2020	170.77
Standing Water Level	mAHD	DG_A_I_PZ_GW08	6/07/2020	177.53
Standing Water Level	mAHD	DG_A_I_PZ_WRK302	6/07/2020	176.77
Standing Water Level	mAHD	DG_A_I_PZ_GW06	6/07/2020	176.224
Standing Water Level	mAHD	DG_A_I_PZ_BW36A	7/07/2020	174.475
Standing Water Level	mAHD	DG_A_I_PZ_GW01	7/07/2020	173.475
Standing Water Level	mAHD	DG_A_I_PZ_BW45B	7/07/2020	177.37
Standing Water Level	mAHD	DG_A_I_PZ_IWB2	8/07/2020	179.656
Standing Water Level	mAHD	DG_A_I_PZ_IWB6	8/07/2020	176.85
Standing Water Level	mAHD	DG_A_I_PZ_BW05	8/07/2020	147.439
Standing Water Level	mAHD	DG_A_I_PZ_BW28A	8/07/2020	152.5
Standing Water Level	mAHD	DG_A_I_PZ_BW53/Puls	9/07/2020	175.81
Standing Water Level	mAHD	DG_A_I_PZ_GW05	9/07/2020	178.89
Standing Water Level	mAHD	DG_A_I_PZ_GW04	9/07/2020	178.13
Standing Water Level	mAHD	DG_A_I_PZ_WRK300	13/07/2020	175.11
Standing Water Level	mAHD	DG_A_I_PZ_WRK303	13/07/2020	179.84
Standing Water Level	mAHD	DG_A_I_PZ_WRK301	13/07/2020	178.18
Standing Water Level	mAHD	DG_A_I_PZ_WRK304	14/07/2020	180.44
Standing Water Level	mAHD	DG_A_I_PZ_BW28A	10/08/2020	152.48
Standing Water Level	mAHD	DG_A_I_PZ_GW02	10/08/2020	170.78
Standing Water Level	mAHD	DG_A_I_PZ_GW01	10/08/2020	173.515
Standing Water Level	mAHD	DG_A_I_PZ_GW04	10/08/2020	178.17
Standing Water Level	mAHD	DG_A_I_PZ_BW53/Puls	17/08/2020	176.29
Standing Water Level	mAHD	DG_A_I_PZ_GW05	17/08/2020	178.94
Standing Water Level	mAHD	DG_A_I_PZ_BW36A	17/08/2020	174.425
Standing Water Level	mAHD	DG_A_I_PZ_WRK303	19/08/2020	179.89
Standing Water Level	mAHD	DG_A_I_PZ_WRK304	19/08/2020	180.49
Standing Water Level	mAHD	DG_A_I_PZ_BW45B	19/08/2020	177.35
Standing Water Level	mAHD	DG_A_I_PZ_GW07	20/08/2020	172.476
Standing Water Level	mAHD	DG_A_I_PZ_GW03	20/08/2020	162.05
Standing Water Level	mAHD	DG_A_I_PZ_WRK300	20/08/2020	175.07
Standing Water Level	mAHD	DG_A_I_PZ_IWB2	20/08/2020	179.876
Standing Water Level	mAHD	DG_A_I_PZ_IWB6	20/08/2020	177
Standing Water Level	mAHD	DG_A_I_PZ_GW06	25/08/2020	176.184
Standing Water Level	mAHD	DG_A_I_PZ_GW08	25/08/2020	177.59
Standing Water Level	mAHD	DG_A_I_PZ_WRK302	25/08/2020	176.71
Standing Water Level	mAHD	DG_A_I_PZ_WRK301	25/08/2020	178.19
Standing Water Level	mAHD	DG_A_I_PZ_WRK302	3/09/2020	176.75
Standing Water Level	mAHD	DG_A_I_PZ_GW03	3/09/2020	162.01
Standing Water Level	mAHD	DG_A_I_PZ_GW02	3/09/2020	170.72
Standing Water Level	mAHD	DG_A_I_PZ_GW07	7/09/2020	172.516
Standing Water Level	mAHD	DG_A_I_PZ_GW05	7/09/2020	178.88
Standing Water Level	mAHD	DG_A_I_PZ_GW04	7/09/2020	178.13

Variable	Unit	Sample Point	Date	Result
Standing Water Level	mAHD	DG_A_I_PZ_BW36A	7/09/2020	174.635
Standing Water Level	mAHD	DG_A_I_PZ_GW01	7/09/2020	173.425
Standing Water Level	mAHD	DG_A_I_PZ_BW45B	7/09/2020	177.38
Standing Water Level	mAHD	DG_A_I_PZ_GW08	8/09/2020	177.41
Standing Water Level	mAHD	DG_A_I_PZ_GW06	8/09/2020	176.114
Standing Water Level	mAHD	DG_A_I_PZ_WRK300	8/09/2020	175.14
Standing Water Level	mAHD	DG_A_I_PZ_IWB2	8/09/2020	179.716
Standing Water Level	mAHD	DG_A_I_PZ_IWB6	8/09/2020	176.68
Standing Water Level	mAHD	DG_A_I_PZ_BW53/Puls	8/09/2020	176.23
Standing Water Level	mAHD	DG_A_I_PZ_WRK304	9/09/2020	180.46
Standing Water Level	mAHD	DG_A_I_PZ_WRK303	9/09/2020	179.85
Standing Water Level	mAHD	DG_A_I_PZ_WRK301	9/09/2020	178.23
Standing Water Level	mAHD	DG_A_I_PZ_BW53/Puls	12/10/2020	176.26
Standing Water Level	mAHD	DG_A_I_PZ_IWB2	12/10/2020	179.716
Standing Water Level	mAHD	DG_A_I_PZ_IWB6	12/10/2020	176.76
Standing Water Level	mAHD	DG_A_I_PZ_GW04	15/10/2020	178.2
Standing Water Level	mAHD	DG_A_I_PZ_GW03	15/10/2020	162.06
Standing Water Level	mAHD	DG_A_I_PZ_GW02	15/10/2020	170.86
Standing Water Level	mAHD	DG_A_I_PZ_GW07	16/10/2020	172.536
Standing Water Level	mAHD	DG_A_I_PZ_GW01	16/10/2020	173.415
Standing Water Level	mAHD	DG_A_I_PZ_BW45B	16/10/2020	177.34
Standing Water Level	mAHD	DG_A_I_PZ_GW05	19/10/2020	178.94
Standing Water Level	mAHD	DG_A_I_PZ_BW36A	19/10/2020	174.385
Standing Water Level	mAHD	DG_A_I_PZ_WRK300	19/10/2020	175.21
Standing Water Level	mAHD	DG_A_I_PZ_GW08	19/10/2020	177.56
Standing Water Level	mAHD	DG_A_I_PZ_WRK302	19/10/2020	176.69
Standing Water Level	mAHD	DG_A_I_PZ_GW06	19/10/2020	176.174
Standing Water Level	mAHD	DG_A_I_PZ_WRK304	20/10/2020	180.39
Standing Water Level	mAHD	DG_A_I_PZ_WRK303	20/10/2020	179.9
Standing Water Level	mAHD	DG_A_I_PZ_WRK301	20/10/2020	178.24
Standing Water Level	mAHD	DG_A_I_PZ_GW07	24/11/2020	172.466
Standing Water Level	mAHD	DG_A_I_PZ_GW03	24/11/2020	162.01
Standing Water Level	mAHD	DG_A_I_PZ_GW02	24/11/2020	170.79
Standing Water Level	mAHD	DG_A_I_PZ_GW01	24/11/2020	173.435
Standing Water Level	mAHD	DG_A_I_PZ_BW45B	24/11/2020	177.36
Standing Water Level	mAHD	DG_A_I_PZ_IWB2	24/11/2020	179.756
Standing Water Level	mAHD	DG_A_I_PZ_IWB6	24/11/2020	176.38
Standing Water Level	mAHD	DG_A_I_PZ_BW53/Puls	24/11/2020	176.18
Standing Water Level	mAHD	DG_A_I_PZ_GW04	25/11/2020	178.29
Standing Water Level	mAHD	DG_A_I_PZ_GW05	25/11/2020	179
Standing Water Level	mAHD	DG_A_I_PZ_BW36A	25/11/2020	174.465
Standing Water Level	mAHD	DG_A_I_PZ_WRK300	25/11/2020	175.16
Standing Water Level	mAHD	DG_A_I_PZ_GW08	26/11/2020	177.48
Standing Water Level	mAHD	DG_A_I_PZ_WRK302	26/11/2020	176.77

Variable	Unit	Sample Point	Date	Result
Standing Water Level	mAHD	DG_A_I_PZ_GW06	26/11/2020	176.214
Standing Water Level	mAHD	DG_A_I_PZ_WRK304	30/11/2020	180.37
Standing Water Level	mAHD	DG_A_I_PZ_WRK303	30/11/2020	179.88
Standing Water Level	mAHD	DG_A_I_PZ_WRK301	30/11/2020	178.18
Standing Water Level	mAHD	DG_A_I_PZ_GW05	4/12/2020	178.97
Standing Water Level	mAHD	DG_A_I_PZ_GW07	8/12/2020	172.536
Standing Water Level	mAHD	DG_A_I_PZ_GW03	8/12/2020	162.04
Standing Water Level	mAHD	DG_A_I_PZ_GW02	8/12/2020	170.8
Standing Water Level	mAHD	DG_A_I_PZ_BW45B	9/12/2020	177.4
Standing Water Level	mAHD	DG_A_I_PZ_GW01	9/12/2020	173.515
Standing Water Level	mAHD	DG_A_I_PZ_GW04	9/12/2020	178.27
Standing Water Level	mAHD	DG_A_I_PZ_BW36A	9/12/2020	174.465
Standing Water Level	mAHD	DG_A_I_PZ_GW04A	10/12/2020	-24.48
Standing Water Level	mAHD	DG_A_I_PZ_GW08	10/12/2020	177.45
Standing Water Level	mAHD	DG_A_I_PZ_WRK302	10/12/2020	176.75
Standing Water Level	mAHD	DG_A_I_PZ_GW06	10/12/2020	176.204
Standing Water Level	mAHD	DG_A_I_PZ_BW53/Puls	10/12/2020	176.25
Standing Water Level	mAHD	DG_A_I_PZ_IWB2	10/12/2020	179.696
Standing Water Level	mAHD	DG_A_I_PZ_IWB6	10/12/2020	176.54
Standing Water Level	mAHD	DG_A_I_PZ_WRK304	14/12/2020	180.41
Standing Water Level	mAHD	DG_A_I_PZ_WRK303	14/12/2020	179.85
Standing Water Level	mAHD	DG_A_I_PZ_WRK301	14/12/2020	178.21
Standing Water Level	mAHD	DG_A_I_PZ_WRK300	14/12/2020	175.18
Standing Water Level (mBTOC)	m	DG_A_I_PZ_GW07	2/07/2020	16.31
Standing Water Level (mBTOC)	m	DG_A_I_PZ_GW03	2/07/2020	10.4
Standing Water Level (mBTOC)	m	DG_A_I_PZ_GW02	2/07/2020	15.61
Standing Water Level (mBTOC)	m	DG_A_I_PZ_GW08	6/07/2020	13.44
Standing Water Level (mBTOC)	m	DG_A_I_PZ_WRK302	6/07/2020	13.51
Standing Water Level (mBTOC)	m	DG_A_I_PZ_GW06	6/07/2020	13.29
Standing Water Level (mBTOC)	m	DG_A_I_PZ_BW36A	7/07/2020	26.26
Standing Water Level (mBTOC)	m	DG_A_I_PZ_GW01	7/07/2020	19.04
Standing Water Level (mBTOC)	m	DG_A_I_PZ_BW45B	7/07/2020	19.88
Standing Water Level (mBTOC)	m	DG_A_I_PZ_IWB2	8/07/2020	12.26
Standing Water Level (mBTOC)	m	DG_A_I_PZ_IWB6	8/07/2020	1.85
Standing Water Level (mBTOC)	m	DG_A_I_PZ_BW05	8/07/2020	5.33
Standing Water Level (mBTOC)	m	DG_A_I_PZ_BW28A	8/07/2020	4.19
Standing Water Level (mBTOC)	m	DG_A_I_PZ_BW53/Puls	9/07/2020	10.32
Standing Water Level (mBTOC)	m	DG_A_I_PZ_GW05	9/07/2020	21.41
Standing Water Level (mBTOC)	m	DG_A_I_PZ_GW04	9/07/2020	24.11
Standing Water Level (mBTOC)	m	DG_A_I_PZ_WRK300	13/07/2020	24.51
Standing Water Level (mBTOC)	m	DG_A_I_PZ_WRK303	13/07/2020	20.56
Standing Water Level (mBTOC)	m	DG_A_I_PZ_WRK301	13/07/2020	18.6
Standing Water Level (mBTOC)	m	DG_A_I_PZ_WRK304	14/07/2020	18.63
Standing Water Level (mBTOC)	m	DG_A_I_PZ_BW28A	10/08/2020	4.21

Variable	Unit	Sample Point	Date	Result
Standing Water Level (mBTOC)	m	DG_A_I_PZ_GW02	10/08/2020	15.6
Standing Water Level (mBTOC)	m	DG_A_I_PZ_GW01	10/08/2020	19
Standing Water Level (mBTOC)	m	DG_A_I_PZ_GW04	10/08/2020	24.07
Standing Water Level (mBTOC)	m	DG_A_I_PZ_BW53/Puls	17/08/2020	9.84
Standing Water Level (mBTOC)	m	DG_A_I_PZ_GW05	17/08/2020	21.36
Standing Water Level (mBTOC)	m	DG_A_I_PZ_BW36A	17/08/2020	26.31
Standing Water Level (mBTOC)	m	DG_A_I_PZ_WRK303	19/08/2020	20.51
Standing Water Level (mBTOC)	m	DG_A_I_PZ_WRK304	19/08/2020	18.58
Standing Water Level (mBTOC)	m	DG_A_I_PZ_BW45B	19/08/2020	19.9
Standing Water Level (mBTOC)	m	DG_A_I_PZ_GW07	20/08/2020	16.37
Standing Water Level (mBTOC)	m	DG_A_I_PZ_GW03	20/08/2020	10.37
Standing Water Level (mBTOC)	m	DG_A_I_PZ_WRK300	20/08/2020	24.55
Standing Water Level (mBTOC)	m	DG_A_I_PZ_IWB2	20/08/2020	12.04
Standing Water Level (mBTOC)	m	DG_A_I_PZ_IWB6	20/08/2020	1.7
Standing Water Level (mBTOC)	m	DG_A_I_PZ_GW06	25/08/2020	13.33
Standing Water Level (mBTOC)	m	DG_A_I_PZ_GW08	25/08/2020	13.38
Standing Water Level (mBTOC)	m	DG_A_I_PZ_WRK302	25/08/2020	13.57
Standing Water Level (mBTOC)	m	DG_A_I_PZ_WRK301	25/08/2020	18.59
Standing Water Level (mBTOC)	m	DG_A_I_PZ_WRK302	3/09/2020	13.53
Standing Water Level (mBTOC)	m	DG_A_I_PZ_GW03	3/09/2020	10.41
Standing Water Level (mBTOC)	m	DG_A_I_PZ_GW02	3/09/2020	15.66
Standing Water Level (mBTOC)	m	DG_A_I_PZ_GW07	7/09/2020	16.33
Standing Water Level (mBTOC)	m	DG_A_I_PZ_GW05	7/09/2020	21.42
Standing Water Level (mBTOC)	m	DG_A_I_PZ_GW04	7/09/2020	24.11
Standing Water Level (mBTOC)	m	DG_A_I_PZ_BW36A	7/09/2020	26.1
Standing Water Level (mBTOC)	m	DG_A_I_PZ_GW01	7/09/2020	19.09
Standing Water Level (mBTOC)	m	DG_A_I_PZ_BW45B	7/09/2020	19.87
Standing Water Level (mBTOC)	m	DG_A_I_PZ_GW08	8/09/2020	13.56
Standing Water Level (mBTOC)	m	DG_A_I_PZ_GW06	8/09/2020	13.4
Standing Water Level (mBTOC)	m	DG_A_I_PZ_WRK300	8/09/2020	24.48
Standing Water Level (mBTOC)	m	DG_A_I_PZ_IWB2	8/09/2020	12.2
Standing Water Level (mBTOC)	m	DG_A_I_PZ_IWB6	8/09/2020	2.02
Standing Water Level (mBTOC)	m	DG_A_I_PZ_BW53/Puls	8/09/2020	9.9
Standing Water Level (mBTOC)	m	DG_A_I_PZ_WRK304	9/09/2020	18.61
Standing Water Level (mBTOC)	m	DG_A_I_PZ_WRK303	9/09/2020	20.55
Standing Water Level (mBTOC)	m	DG_A_I_PZ_WRK301	9/09/2020	18.55
Standing Water Level (mBTOC)	m	DG_A_I_PZ_BW53/Puls	12/10/2020	9.87
Standing Water Level (mBTOC)	m	DG_A_I_PZ_IWB2	12/10/2020	12.2
Standing Water Level (mBTOC)	m	DG_A_I_PZ_IWB6	12/10/2020	1.94
Standing Water Level (mBTOC)	m	DG_A_I_PZ_GW04	15/10/2020	24.04
Standing Water Level (mBTOC)	m	DG_A_I_PZ_GW03	15/10/2020	10.36
Standing Water Level (mBTOC)	m	DG_A_I_PZ_GW02	15/10/2020	15.52
Standing Water Level (mBTOC)	m	DG_A_I_PZ_GW07	16/10/2020	16.31
Standing Water Level (mBTOC)	m	DG_A_I_PZ_GW01	16/10/2020	19.1

Variable	Unit	Sample Point	Date	Result
Standing Water Level (mBTOC)	m	DG_A_I_PZ_BW45B	16/10/2020	19.91
Standing Water Level (mBTOC)	m	DG_A_I_PZ_GW05	19/10/2020	21.36
Standing Water Level (mBTOC)	m	DG_A_I_PZ_BW36A	19/10/2020	26.35
Standing Water Level (mBTOC)	m	DG_A_I_PZ_WRK300	19/10/2020	24.41
Standing Water Level (mBTOC)	m	DG_A_I_PZ_GW08	19/10/2020	13.41
Standing Water Level (mBTOC)	m	DG_A_I_PZ_WRK302	19/10/2020	13.59
Standing Water Level (mBTOC)	m	DG_A_I_PZ_GW06	19/10/2020	13.34
Standing Water Level (mBTOC)	m	DG_A_I_PZ_WRK304	20/10/2020	18.68
Standing Water Level (mBTOC)	m	DG_A_I_PZ_WRK303	20/10/2020	20.5
Standing Water Level (mBTOC)	m	DG_A_I_PZ_WRK301	20/10/2020	18.54
Standing Water Level (mBTOC)	m	DG_A_I_PZ_GW07	24/11/2020	16.38
Standing Water Level (mBTOC)	m	DG_A_I_PZ_GW03	24/11/2020	10.41
Standing Water Level (mBTOC)	m	DG_A_I_PZ_GW02	24/11/2020	15.59
Standing Water Level (mBTOC)	m	DG_A_I_PZ_GW01	24/11/2020	19.08
Standing Water Level (mBTOC)	m	DG_A_I_PZ_BW45B	24/11/2020	19.89
Standing Water Level (mBTOC)	m	DG_A_I_PZ_IWB2	24/11/2020	12.16
Standing Water Level (mBTOC)	m	DG_A_I_PZ_IWB6	24/11/2020	2.32
Standing Water Level (mBTOC)	m	DG_A_I_PZ_BW53/Puls	24/11/2020	9.95
Standing Water Level (mBTOC)	m	DG_A_I_PZ_GW04	25/11/2020	23.95
Standing Water Level (mBTOC)	m	DG_A_I_PZ_GW05	25/11/2020	21.3
Standing Water Level (mBTOC)	m	DG_A_I_PZ_BW36A	25/11/2020	26.27
Standing Water Level (mBTOC)	m	DG_A_I_PZ_WRK300	25/11/2020	24.46
Standing Water Level (mBTOC)	m	DG_A_I_PZ_GW08	26/11/2020	13.49
Standing Water Level (mBTOC)	m	DG_A_I_PZ_WRK302	26/11/2020	13.51
Standing Water Level (mBTOC)	m	DG_A_I_PZ_GW06	26/11/2020	13.3
Standing Water Level (mBTOC)	m	DG_A_I_PZ_GW04A	30/11/2020	24.42
Standing Water Level (mBTOC)	m	DG_A_I_PZ_WRK304	30/11/2020	18.7
Standing Water Level (mBTOC)	m	DG_A_I_PZ_WRK303	30/11/2020	20.52
Standing Water Level (mBTOC)	m	DG_A_I_PZ_WRK301	30/11/2020	18.6
Standing Water Level (mBTOC)	m	DG_A_I_PZ_GW05	4/12/2020	21.33
Standing Water Level (mBTOC)	m	DG_A_I_PZ_GW07	8/12/2020	16.31
Standing Water Level (mBTOC)	m	DG_A_I_PZ_GW03	8/12/2020	10.38
Standing Water Level (mBTOC)	m	DG_A_I_PZ_GW02	8/12/2020	15.58
Standing Water Level (mBTOC)	m	DG_A_I_PZ_BW45B	9/12/2020	19.85
Standing Water Level (mBTOC)	m	DG_A_I_PZ_GW01	9/12/2020	19
Standing Water Level (mBTOC)	m	DG_A_I_PZ_GW04	9/12/2020	23.97
Standing Water Level (mBTOC)	m	DG_A_I_PZ_BW36A	9/12/2020	26.27
Standing Water Level (mBTOC)	m	DG_A_I_PZ_GW04A	10/12/2020	24.48
Standing Water Level (mBTOC)	m	DG_A_I_PZ_GW08	10/12/2020	13.52
Standing Water Level (mBTOC)	m	DG_A_I_PZ_WRK302	10/12/2020	13.53
Standing Water Level (mBTOC)	m	DG_A_I_PZ_GW06	10/12/2020	13.31
Standing Water Level (mBTOC)	m	DG_A_I_PZ_BW53/Puls	10/12/2020	9.88
Standing Water Level (mBTOC)	m	DG_A_I_PZ_IWB2	10/12/2020	12.22
Standing Water Level (mBTOC)	m	DG_A_I_PZ_IWB6	10/12/2020	2.16

Variable	Unit	Sample Point	Date	Result
Standing Water Level (mBTOC)	m	DG_A_I_PZ_WRK304	14/12/2020	18.66
Standing Water Level (mBTOC)	m	DG_A_I_PZ_WRK303	14/12/2020	20.55
Standing Water Level (mBTOC)	m	DG_A_I_PZ_WRK301	14/12/2020	18.57
Standing Water Level (mBTOC)	m	DG_A_I_PZ_WRK300	14/12/2020	24.44
Strontium (Total)	mg/L	DG_A_I_PZ_GW07	2/07/2020	5.5
Strontium (Total)	mg/L	DG_A_I_PZ_GW03	2/07/2020	2
Strontium (Total)	mg/L	DG_A_I_PZ_GW02	2/07/2020	0.53
Strontium (Total)	mg/L	DG_A_I_PZ_GW08	6/07/2020	5.8
Strontium (Total)	mg/L	DG_A_I_PZ_WRK302	6/07/2020	6.2
Strontium (Total)	mg/L	DG_A_I_PZ_GW06	6/07/2020	9.1
Strontium (Total)	mg/L	DG_A_I_PZ_BW36A	7/07/2020	1.1
Strontium (Total)	mg/L	DG_A_I_PZ_GW01	7/07/2020	1.2
Strontium (Total)	mg/L	DG_A_I_PZ_BW45B	7/07/2020	4
Strontium (Total)	mg/L	DG_A_I_PZ_IWB2	8/07/2020	0.3
Strontium (Total)	mg/L	DG_A_I_PZ_IWB6	8/07/2020	0.05
Strontium (Total)	mg/L	DG_A_I_PZ_BW05	8/07/2020	7.3
Strontium (Total)	mg/L	DG_A_I_PZ_BW28A	8/07/2020	7.6
Strontium (Total)	mg/L	DG_A_I_PZ_BW53/Puls	9/07/2020	0.42
Strontium (Total)	mg/L	DG_A_I_PZ_GW05	9/07/2020	1.3
Strontium (Total)	mg/L	DG_A_I_PZ_GW04	9/07/2020	1.7
Strontium (Total)	mg/L	DG_A_I_PZ_WRK300	13/07/2020	1.3
Strontium (Total)	mg/L	DG_A_I_PZ_WRK303	13/07/2020	1.8
Strontium (Total)	mg/L	DG_A_I_PZ_WRK301	13/07/2020	3.6
Strontium (Total)	mg/L	DG_A_I_PZ_WRK304	14/07/2020	1.5
Strontium (Total)	mg/L	DG_A_I_PZ_GW04	10/08/2020	2.1
Strontium (Total)	mg/L	DG_A_I_PZ_BW28A	10/08/2020	9.2
Strontium (Total)	mg/L	DG_A_I_PZ_GW02	10/08/2020	0.66
Strontium (Total)	mg/L	DG_A_I_PZ_GW01	10/08/2020	2
Strontium (Total)	mg/L	DG_A_I_PZ_BW36A	17/08/2020	1.2
Strontium (Total)	mg/L	DG_A_I_PZ_BW53/Puls	17/08/2020	0.38
Strontium (Total)	mg/L	DG_A_I_PZ_GW05	17/08/2020	1.4
Strontium (Total)	mg/L	DG_A_I_PZ_WRK303	19/08/2020	1.7
Strontium (Total)	mg/L	DG_A_I_PZ_BW45B	19/08/2020	4.2
Strontium (Total)	mg/L	DG_A_I_PZ_WRK304	19/08/2020	1.3
Strontium (Total)	mg/L	DG_A_I_PZ_WRK302	3/09/2020	6.1
Strontium (Total)	mg/L	DG_A_I_PZ_GW04	15/10/2020	1.7
Strontium (Total)	mg/L	DG_A_I_PZ_GW04A	30/11/2020	1.4
Strontium (Total)	mg/L	DG_A_I_PZ_GW04A	30/12/2020	1.4
Sulfate	mg/L	DG_A_I_PZ_GW07	2/07/2020	940
Sulfate	mg/L	DG_A_I_PZ_GW03	2/07/2020	570
Sulfate	mg/L	DG_A_I_PZ_GW02	2/07/2020	420
Sulfate	mg/L	DG_A_I_PZ_GW08	6/07/2020	1300
Sulfate	mg/L	DG_A_I_PZ_WRK302	6/07/2020	1400
Sulfate	mg/L	DG_A_I_PZ_GW06	6/07/2020	1500

Variable	Unit	Sample Point	Date	Result
Sulfate	mg/L	DG_A_I_PZ_BW36A	7/07/2020	240
Sulfate	mg/L	DG_A_I_PZ_GW01	7/07/2020	500
Sulfate	mg/L	DG_A_I_PZ_BW45B	7/07/2020	900
Sulfate	mg/L	DG_A_I_PZ_IWB2	8/07/2020	150
Sulfate	mg/L	DG_A_I_PZ_IWB6	8/07/2020	200
Sulfate	mg/L	DG_A_I_PZ_BW05	8/07/2020	880
Sulfate	mg/L	DG_A_I_PZ_BW28A	8/07/2020	920
Sulfate	mg/L	DG_A_I_PZ_BW53/Puls	9/07/2020	340
Sulfate	mg/L	DG_A_I_PZ_GW05	9/07/2020	640
Sulfate	mg/L	DG_A_I_PZ_GW04	9/07/2020	620
Sulfate	mg/L	DG_A_I_PZ_WRK300	13/07/2020	320
Sulfate	mg/L	DG_A_I_PZ_WRK303	13/07/2020	580
Sulfate	mg/L	DG_A_I_PZ_WRK301	13/07/2020	600
Sulfate	mg/L	DG_A_I_PZ_WRK304	14/07/2020	650
Sulfate	mg/L	DG_A_I_PZ_GW04	10/08/2020	600
Sulfate	mg/L	DG_A_I_PZ_BW28A	10/08/2020	870
Sulfate	mg/L	DG_A_I_PZ_GW02	10/08/2020	370
Sulfate	mg/L	DG_A_I_PZ_GW01	10/08/2020	440
Sulfate	mg/L	DG_A_I_PZ_BW36A	17/08/2020	220
Sulfate	mg/L	DG_A_I_PZ_BW53/Puls	17/08/2020	270
Sulfate	mg/L	DG_A_I_PZ_GW05	17/08/2020	590
Sulfate	mg/L	DG_A_I_PZ_WRK303	19/08/2020	590
Sulfate	mg/L	DG_A_I_PZ_BW45B	19/08/2020	810
Sulfate	mg/L	DG_A_I_PZ_WRK304	19/08/2020	640
Sulfate	mg/L	DG_A_I_PZ_WRK302	3/09/2020	1400
Sulfate	mg/L	DG_A_I_PZ_GW04	15/10/2020	670
Sulfate	mg/L	DG_A_I_PZ_GW04A	30/11/2020	360
Sulfate	mg/L	DG_A_I_PZ_GW04A	30/12/2020	360
Temperature	°C	DG_A_I_PZ_GW07	2/07/2020	17.9
Temperature	°C	DG_A_I_PZ_GW03	2/07/2020	18
Temperature	°C	DG_A_I_PZ_GW02	2/07/2020	17.7
Temperature	°C	DG_A_I_PZ_GW08	6/07/2020	17.7
Temperature	°C	DG_A_I_PZ_WRK302	6/07/2020	17.2
Temperature	°C	DG_A_I_PZ_GW06	6/07/2020	17.6
Temperature	°C	DG_A_I_PZ_BW36A	7/07/2020	14.9
Temperature	°C	DG_A_I_PZ_GW01	7/07/2020	15.6
Temperature	°C	DG_A_I_PZ_BW45B	7/07/2020	14.9
Temperature	°C	DG_A_I_PZ_IWB2	8/07/2020	17.7
Temperature	°C	DG_A_I_PZ_IWB6	8/07/2020	16.9
Temperature	°C	DG_A_I_PZ_BW05	8/07/2020	17.2
Temperature	°C	DG_A_I_PZ_BW28A	8/07/2020	17.5
Temperature	°C	DG_A_I_PZ_BW53/Puls	9/07/2020	15.1
Temperature	°C	DG_A_I_PZ_GW05	9/07/2020	14.6
Temperature	°C	DG_A_I_PZ_GW04	9/07/2020	15.1

Variable	Unit	Sample Point	Date	Result
Temperature	°C	DG_A_I_PZ_WRK300	13/07/2020	14.1
Temperature	°C	DG_A_I_PZ_WRK303	13/07/2020	17.5
Temperature	°C	DG_A_I_PZ_WRK301	13/07/2020	17.4
Temperature	°C	DG_A_I_PZ_WRK304	14/07/2020	17
Temperature	°C	DG_A_I_PZ_BW28A	10/08/2020	17.5
Temperature	°C	DG_A_I_PZ_GW02	10/08/2020	17.7
Temperature	°C	DG_A_I_PZ_GW01	10/08/2020	16.5
Temperature	°C	DG_A_I_PZ_GW04	10/08/2020	18
Temperature	°C	DG_A_I_PZ_BW53/Puls	17/08/2020	15.5
Temperature	°C	DG_A_I_PZ_GW05	17/08/2020	16.5
Temperature	°C	DG_A_I_PZ_BW36A	17/08/2020	16.3
Temperature	°C	DG_A_I_PZ_WRK303	19/08/2020	15
Temperature	°C	DG_A_I_PZ_WRK304	19/08/2020	15.2
Temperature	°C	DG_A_I_PZ_BW45B	19/08/2020	13.2
Temperature	°C	DG_A_I_PZ_GW07	20/08/2020	18.3
Temperature	°C	DG_A_I_PZ_GW03	20/08/2020	17.3
Temperature	°C	DG_A_I_PZ_WRK300	20/08/2020	14
Temperature	°C	DG_A_I_PZ_GW06	25/08/2020	17.5
Temperature	°C	DG_A_I_PZ_GW08	25/08/2020	17.4
Temperature	°C	DG_A_I_PZ_WRK302	25/08/2020	17.1
Temperature	°C	DG_A_I_PZ_WRK301	25/08/2020	17.6
Temperature	°C	DG_A_I_PZ_WRK302	3/09/2020	17.2
Temperature	°C	DG_A_I_PZ_GW03	3/09/2020	17.9
Temperature	°C	DG_A_I_PZ_GW02	3/09/2020	17.6
Temperature	°C	DG_A_I_PZ_GW07	7/09/2020	18.1
Temperature	°C	DG_A_I_PZ_GW05	7/09/2020	18.2
Temperature	°C	DG_A_I_PZ_GW04	7/09/2020	21
Temperature	°C	DG_A_I_PZ_BW36A	7/09/2020	21
Temperature	°C	DG_A_I_PZ_GW01	7/09/2020	20
Temperature	°C	DG_A_I_PZ_BW45B	7/09/2020	20.5
Temperature	°C	DG_A_I_PZ_GW08	8/09/2020	17.7
Temperature	°C	DG_A_I_PZ_GW06	8/09/2020	17.7
Temperature	°C	DG_A_I_PZ_WRK300	8/09/2020	16.1
Temperature	°C	DG_A_I_PZ_WRK304	9/09/2020	17
Temperature	°C	DG_A_I_PZ_WRK303	9/09/2020	17.1
Temperature	°C	DG_A_I_PZ_WRK301	9/09/2020	17.3
Temperature	°C	DG_A_I_PZ_GW04	15/10/2020	18
Temperature	°C	DG_A_I_PZ_GW03	15/10/2020	18.3
Temperature	°C	DG_A_I_PZ_GW02	15/10/2020	17.8
Temperature	°C	DG_A_I_PZ_GW07	16/10/2020	18.1
Temperature	°C	DG_A_I_PZ_GW01	16/10/2020	16.5
Temperature	°C	DG_A_I_PZ_BW45B	16/10/2020	16.3
Temperature	°C	DG_A_I_PZ_GW05	19/10/2020	16.8
Temperature	°C	DG_A_I_PZ_BW36A	19/10/2020	16.5

Variable	Unit	Sample Point	Date	Result
Temperature	°C	DG_A_I_PZ_WRK300	19/10/2020	16.6
Temperature	°C	DG_A_I_PZ_GW08	19/10/2020	17.7
Temperature	°C	DG_A_I_PZ_WRK302	19/10/2020	17.2
Temperature	°C	DG_A_I_PZ_GW06	19/10/2020	17.7
Temperature	°C	DG_A_I_PZ_WRK304	20/10/2020	16.9
Temperature	°C	DG_A_I_PZ_WRK303	20/10/2020	18.8
Temperature	°C	DG_A_I_PZ_WRK301	20/10/2020	18.5
Temperature	°C	DG_A_I_PZ_GW07	24/11/2020	18.1
Temperature	°C	DG_A_I_PZ_GW03	24/11/2020	19.8
Temperature	°C	DG_A_I_PZ_GW02	24/11/2020	17.8
Temperature	°C	DG_A_I_PZ_GW01	24/11/2020	20.7
Temperature	°C	DG_A_I_PZ_BW45B	24/11/2020	21.4
Temperature	°C	DG_A_I_PZ_GW04	25/11/2020	22.7
Temperature	°C	DG_A_I_PZ_GW05	25/11/2020	22.4
Temperature	°C	DG_A_I_PZ_BW36A	25/11/2020	25
Temperature	°C	DG_A_I_PZ_WRK300	25/11/2020	23.9
Temperature	°C	DG_A_I_PZ_GW08	26/11/2020	18.1
Temperature	°C	DG_A_I_PZ_WRK302	26/11/2020	17.3
Temperature	°C	DG_A_I_PZ_GW06	26/11/2020	17.5
Temperature	°C	DG_A_I_PZ_GW04A	30/11/2020	18.4
Temperature	°C	DG_A_I_PZ_WRK304	30/11/2020	17.8
Temperature	°C	DG_A_I_PZ_WRK303	30/11/2020	18.3
Temperature	°C	DG_A_I_PZ_WRK301	30/11/2020	22
Temperature	°C	DG_A_I_PZ_GW05	4/12/2020	19.3
Temperature	°C	DG_A_I_PZ_GW07	8/12/2020	18
Temperature	°C	DG_A_I_PZ_GW03	8/12/2020	18.8
Temperature	°C	DG_A_I_PZ_GW02	8/12/2020	17.5
Temperature	°C	DG_A_I_PZ_BW45B	9/12/2020	17
Temperature	°C	DG_A_I_PZ_GW01	9/12/2020	17
Temperature	°C	DG_A_I_PZ_GW04	9/12/2020	19.9
Temperature	°C	DG_A_I_PZ_BW36A	9/12/2020	21.3
Temperature	°C	DG_A_I_PZ_GW04A	10/12/2020	17.7
Temperature	°C	DG_A_I_PZ_GW08	10/12/2020	17.8
Temperature	°C	DG_A_I_PZ_WRK302	10/12/2020	17.8
Temperature	°C	DG_A_I_PZ_GW06	10/12/2020	17.9
Temperature	°C	DG_A_I_PZ_WRK304	14/12/2020	17.7
Temperature	°C	DG_A_I_PZ_WRK303	14/12/2020	18.2
Temperature	°C	DG_A_I_PZ_WRK301	14/12/2020	25.2
Temperature	°C	DG_A_I_PZ_WRK300	14/12/2020	27.4
Thallium (Total)	mg/L	DG_A_I_PZ_GW07	2/07/2020	0.001
Thallium (Total)	mg/L	DG_A_I_PZ_GW03	2/07/2020	0.001
Thallium (Total)	mg/L	DG_A_I_PZ_GW02	2/07/2020	0.001
Thallium (Total)	mg/L	DG_A_I_PZ_GW08	6/07/2020	0.001
Thallium (Total)	mg/L	DG_A_I_PZ_WRK302	6/07/2020	0.001

Variable	Unit	Sample Point	Date	Result
Thallium (Total)	mg/L	DG_A_I_PZ_GW06	6/07/2020	0.001
Thallium (Total)	mg/L	DG_A_I_PZ_BW36A	7/07/2020	0.001
Thallium (Total)	mg/L	DG_A_I_PZ_GW01	7/07/2020	0.001
Thallium (Total)	mg/L	DG_A_I_PZ_BW45B	7/07/2020	0.001
Thallium (Total)	mg/L	DG_A_I_PZ_IWB2	8/07/2020	0.001
Thallium (Total)	mg/L	DG_A_I_PZ_IWB6	8/07/2020	0.001
Thallium (Total)	mg/L	DG_A_I_PZ_BW05	8/07/2020	0.001
Thallium (Total)	mg/L	DG_A_I_PZ_BW28A	8/07/2020	0.001
Thallium (Total)	mg/L	DG_A_I_PZ_BW53/Puls	9/07/2020	0.001
Thallium (Total)	mg/L	DG_A_I_PZ_GW05	9/07/2020	0.001
Thallium (Total)	mg/L	DG_A_I_PZ_GW04	9/07/2020	0.001
Thallium (Total)	mg/L	DG_A_I_PZ_WRK300	13/07/2020	0.001
Thallium (Total)	mg/L	DG_A_I_PZ_WRK303	13/07/2020	0.001
Thallium (Total)	mg/L	DG_A_I_PZ_WRK301	13/07/2020	0.001
Thallium (Total)	mg/L	DG_A_I_PZ_WRK304	14/07/2020	0.001
Thallium (Total)	mg/L	DG_A_I_PZ_GW04	10/08/2020	0.001
Thallium (Total)	mg/L	DG_A_I_PZ_BW28A	10/08/2020	0.001
Thallium (Total)	mg/L	DG_A_I_PZ_GW02	10/08/2020	0.001
Thallium (Total)	mg/L	DG_A_I_PZ_GW01	10/08/2020	0.001
Thallium (Total)	mg/L	DG_A_I_PZ_BW36A	17/08/2020	0.001
Thallium (Total)	mg/L	DG_A_I_PZ_BW53/Puls	17/08/2020	0.001
Thallium (Total)	mg/L	DG_A_I_PZ_GW05	17/08/2020	0.001
Thallium (Total)	mg/L	DG_A_I_PZ_WRK303	19/08/2020	0.004
Thallium (Total)	mg/L	DG_A_I_PZ_BW45B	19/08/2020	0.005
Thallium (Total)	mg/L	DG_A_I_PZ_WRK304	19/08/2020	0.004
Thallium (Total)	mg/L	DG_A_I_PZ_WRK302	3/09/2020	0.001
Thallium (Total)	mg/L	DG_A_I_PZ_GW04	15/10/2020	0.001
Thallium (Total)	mg/L	DG_A_I_PZ_GW04A	30/11/2020	0.001
Thallium (Total)	mg/L	DG_A_I_PZ_GW04A	30/12/2020	0.001
Thorium (Total)	mg/L	DG_A_I_PZ_GW07	2/07/2020	0.002
Thorium (Total)	mg/L	DG_A_I_PZ_GW03	2/07/2020	0.002
Thorium (Total)	mg/L	DG_A_I_PZ_GW02	2/07/2020	0.002
Thorium (Total)	mg/L	DG_A_I_PZ_GW08	6/07/2020	0.002
Thorium (Total)	mg/L	DG_A_I_PZ_WRK302	6/07/2020	0.002
Thorium (Total)	mg/L	DG_A_I_PZ_GW06	6/07/2020	0.002
Thorium (Total)	mg/L	DG_A_I_PZ_BW36A	7/07/2020	0.002
Thorium (Total)	mg/L	DG_A_I_PZ_GW01	7/07/2020	0.002
Thorium (Total)	mg/L	DG_A_I_PZ_BW45B	7/07/2020	0.002
Thorium (Total)	mg/L	DG_A_I_PZ_IWB2	8/07/2020	0.002
Thorium (Total)	mg/L	DG_A_I_PZ_IWB6	8/07/2020	0.002
Thorium (Total)	mg/L	DG_A_I_PZ_BW05	8/07/2020	0.002
Thorium (Total)	mg/L	DG_A_I_PZ_BW28A	8/07/2020	0.002
Thorium (Total)	mg/L	DG_A_I_PZ_BW53/Puls	9/07/2020	0.002
Thorium (Total)	mg/L	DG_A_I_PZ_GW05	9/07/2020	0.002

Variable	Unit	Sample Point	Date	Result
Thorium (Total)	mg/L	DG_A_I_PZ_GW04	9/07/2020	0.002
Thorium (Total)	mg/L	DG_A_I_PZ_WRK300	13/07/2020	0.002
Thorium (Total)	mg/L	DG_A_I_PZ_WRK303	13/07/2020	0.002
Thorium (Total)	mg/L	DG_A_I_PZ_WRK301	13/07/2020	0.002
Thorium (Total)	mg/L	DG_A_I_PZ_WRK304	14/07/2020	0.002
Thorium (Total)	mg/L	DG_A_I_PZ_GW04	10/08/2020	0.002
Thorium (Total)	mg/L	DG_A_I_PZ_BW28A	10/08/2020	0.002
Thorium (Total)	mg/L	DG_A_I_PZ_GW02	10/08/2020	0.002
Thorium (Total)	mg/L	DG_A_I_PZ_GW01	10/08/2020	0.002
Thorium (Total)	mg/L	DG_A_I_PZ_BW36A	17/08/2020	0.002
Thorium (Total)	mg/L	DG_A_I_PZ_BW53/Puls	17/08/2020	0.002
Thorium (Total)	mg/L	DG_A_I_PZ_GW05	17/08/2020	0.002
Thorium (Total)	mg/L	DG_A_I_PZ_WRK303	19/08/2020	0.006
Thorium (Total)	mg/L	DG_A_I_PZ_BW45B	19/08/2020	0.006
Thorium (Total)	mg/L	DG_A_I_PZ_WRK304	19/08/2020	0.006
Thorium (Total)	mg/L	DG_A_I_PZ_WRK302	3/09/2020	0.002
Thorium (Total)	mg/L	DG_A_I_PZ_GW04	15/10/2020	0.002
Thorium (Total)	mg/L	DG_A_I_PZ_GW04A	30/11/2020	0.002
Thorium (Total)	mg/L	DG_A_I_PZ_GW04A	30/12/2020	0.002
Tin (Total)	mg/L	DG_A_I_PZ_GW07	2/07/2020	0.001
Tin (Total)	mg/L	DG_A_I_PZ_GW03	2/07/2020	0.001
Tin (Total)	mg/L	DG_A_I_PZ_GW02	2/07/2020	0.001
Tin (Total)	mg/L	DG_A_I_PZ_GW08	6/07/2020	0.001
Tin (Total)	mg/L	DG_A_I_PZ_WRK302	6/07/2020	0.001
Tin (Total)	mg/L	DG_A_I_PZ_GW06	6/07/2020	0.001
Tin (Total)	mg/L	DG_A_I_PZ_BW36A	7/07/2020	0.001
Tin (Total)	mg/L	DG_A_I_PZ_GW01	7/07/2020	0.001
Tin (Total)	mg/L	DG_A_I_PZ_BW45B	7/07/2020	0.001
Tin (Total)	mg/L	DG_A_I_PZ_IWB2	8/07/2020	0.001
Tin (Total)	mg/L	DG_A_I_PZ_IWB6	8/07/2020	0.001
Tin (Total)	mg/L	DG_A_I_PZ_BW05	8/07/2020	0.001
Tin (Total)	mg/L	DG_A_I_PZ_BW28A	8/07/2020	0.001
Tin (Total)	mg/L	DG_A_I_PZ_BW53/Puls	9/07/2020	0.001
Tin (Total)	mg/L	DG_A_I_PZ_GW05	9/07/2020	0.001
Tin (Total)	mg/L	DG_A_I_PZ_GW04	9/07/2020	0.001
Tin (Total)	mg/L	DG_A_I_PZ_WRK300	13/07/2020	0.001
Tin (Total)	mg/L	DG_A_I_PZ_WRK303	13/07/2020	0.001
Tin (Total)	mg/L	DG_A_I_PZ_WRK301	13/07/2020	0.001
Tin (Total)	mg/L	DG_A_I_PZ_WRK304	14/07/2020	0.001
Tin (Total)	mg/L	DG_A_I_PZ_GW04	10/08/2020	0.001
Tin (Total)	mg/L	DG_A_I_PZ_BW28A	10/08/2020	0.001
Tin (Total)	mg/L	DG_A_I_PZ_GW02	10/08/2020	0.001
Tin (Total)	mg/L	DG_A_I_PZ_GW01	10/08/2020	0.001
Tin (Total)	mg/L	DG_A_I_PZ_BW36A	17/08/2020	0.001

Variable	Unit	Sample Point	Date	Result
Tin (Total)	mg/L	DG_A_I_PZ_BW53/Puls	17/08/2020	0.001
Tin (Total)	mg/L	DG_A_I_PZ_GW05	17/08/2020	0.001
Tin (Total)	mg/L	DG_A_I_PZ_WRK303	19/08/2020	0.001
Tin (Total)	mg/L	DG_A_I_PZ_BW45B	19/08/2020	0.001
Tin (Total)	mg/L	DG_A_I_PZ_WRK304	19/08/2020	0.001
Tin (Total)	mg/L	DG_A_I_PZ_WRK302	3/09/2020	0.001
Tin (Total)	mg/L	DG_A_I_PZ_GW04	15/10/2020	0.001
Tin (Total)	mg/L	DG_A_I_PZ_GW04A	30/11/2020	0.001
Tin (Total)	mg/L	DG_A_I_PZ_GW04A	30/12/2020	0.001
Titanium (Total)	mg/L	DG_A_I_PZ_GW07	2/07/2020	0.001
Titanium (Total)	mg/L	DG_A_I_PZ_GW03	2/07/2020	0.001
Titanium (Total)	mg/L	DG_A_I_PZ_GW02	2/07/2020	0.001
Titanium (Total)	mg/L	DG_A_I_PZ_GW08	6/07/2020	0.001
Titanium (Total)	mg/L	DG_A_I_PZ_WRK302	6/07/2020	0.001
Titanium (Total)	mg/L	DG_A_I_PZ_GW06	6/07/2020	0.009
Titanium (Total)	mg/L	DG_A_I_PZ_BW36A	7/07/2020	0.001
Titanium (Total)	mg/L	DG_A_I_PZ_GW01	7/07/2020	0.002
Titanium (Total)	mg/L	DG_A_I_PZ_BW45B	7/07/2020	0.001
Titanium (Total)	mg/L	DG_A_I_PZ_IWB2	8/07/2020	0.004
Titanium (Total)	mg/L	DG_A_I_PZ_IWB6	8/07/2020	0.001
Titanium (Total)	mg/L	DG_A_I_PZ_BW05	8/07/2020	0.001
Titanium (Total)	mg/L	DG_A_I_PZ_BW28A	8/07/2020	0.001
Titanium (Total)	mg/L	DG_A_I_PZ_BW53/Puls	9/07/2020	0.003
Titanium (Total)	mg/L	DG_A_I_PZ_GW05	9/07/2020	0.001
Titanium (Total)	mg/L	DG_A_I_PZ_GW04	9/07/2020	0.001
Titanium (Total)	mg/L	DG_A_I_PZ_WRK300	13/07/2020	0.001
Titanium (Total)	mg/L	DG_A_I_PZ_WRK303	13/07/2020	0.003
Titanium (Total)	mg/L	DG_A_I_PZ_WRK301	13/07/2020	0.004
Titanium (Total)	mg/L	DG_A_I_PZ_WRK304	14/07/2020	0.002
Titanium (Total)	mg/L	DG_A_I_PZ_GW04	10/08/2020	0.001
Titanium (Total)	mg/L	DG_A_I_PZ_BW28A	10/08/2020	0.001
Titanium (Total)	mg/L	DG_A_I_PZ_GW02	10/08/2020	0.001
Titanium (Total)	mg/L	DG_A_I_PZ_GW01	10/08/2020	0.002
Titanium (Total)	mg/L	DG_A_I_PZ_BW36A	17/08/2020	0.001
Titanium (Total)	mg/L	DG_A_I_PZ_BW53/Puls	17/08/2020	0.074
Titanium (Total)	mg/L	DG_A_I_PZ_GW05	17/08/2020	0.001
Titanium (Total)	mg/L	DG_A_I_PZ_WRK303	19/08/2020	0.001
Titanium (Total)	mg/L	DG_A_I_PZ_BW45B	19/08/2020	0.001
Titanium (Total)	mg/L	DG_A_I_PZ_WRK304	19/08/2020	0.002
Titanium (Total)	mg/L	DG_A_I_PZ_WRK302	3/09/2020	0.001
Titanium (Total)	mg/L	DG_A_I_PZ_GW04	15/10/2020	0.001
Titanium (Total)	mg/L	DG_A_I_PZ_GW04A	30/11/2020	0.001
Titanium (Total)	mg/L	DG_A_I_PZ_GW04A	30/12/2020	0.001
Total Dissolved Solids	mg/L	DG_A_I_PZ_GW07	2/07/2020	11390

Variable	Unit	Sample Point	Date	Result
Total Dissolved Solids	mg/L	DG_A_I_PZ_GW07	2/07/2020	12000
Total Dissolved Solids	mg/L	DG_A_I_PZ_GW03	2/07/2020	7370
Total Dissolved Solids	mg/L	DG_A_I_PZ_GW03	2/07/2020	6800
Total Dissolved Solids	mg/L	DG_A_I_PZ_GW02	2/07/2020	4891
Total Dissolved Solids	mg/L	DG_A_I_PZ_GW02	2/07/2020	4400
Total Dissolved Solids	mg/L	DG_A_I_PZ_GW08	6/07/2020	13400
Total Dissolved Solids	mg/L	DG_A_I_PZ_GW08	6/07/2020	14000
Total Dissolved Solids	mg/L	DG_A_I_PZ_GW08	6/07/2020	13400
Total Dissolved Solids	mg/L	DG_A_I_PZ_WRK302	6/07/2020	13400
Total Dissolved Solids	mg/L	DG_A_I_PZ_WRK302	6/07/2020	13000
Total Dissolved Solids	mg/L	DG_A_I_PZ_GW06	6/07/2020	13400
Total Dissolved Solids	mg/L	DG_A_I_PZ_GW06	6/07/2020	14000
Total Dissolved Solids	mg/L	DG_A_I_PZ_BW36A	7/07/2020	4000
Total Dissolved Solids	mg/L	DG_A_I_PZ_GW01	7/07/2020	7370
Total Dissolved Solids	mg/L	DG_A_I_PZ_GW01	7/07/2020	6600
Total Dissolved Solids	mg/L	DG_A_I_PZ_BW45B	7/07/2020	10720
Total Dissolved Solids	mg/L	DG_A_I_PZ_BW45B	7/07/2020	11000
Total Dissolved Solids	mg/L	DG_A_I_PZ_IWB2	8/07/2020	2680
Total Dissolved Solids	mg/L	DG_A_I_PZ_IWB2	8/07/2020	2200
Total Dissolved Solids	mg/L	DG_A_I_PZ_IWB6	8/07/2020	1139
Total Dissolved Solids	mg/L	DG_A_I_PZ_IWB6	8/07/2020	1139
Total Dissolved Solids	mg/L	DG_A_I_PZ_IWB6	8/07/2020	1100
Total Dissolved Solids	mg/L	DG_A_I_PZ_BW05	8/07/2020	15410
Total Dissolved Solids	mg/L	DG_A_I_PZ_BW05	8/07/2020	14000
Total Dissolved Solids	mg/L	DG_A_I_PZ_BW28A	8/07/2020	14070
Total Dissolved Solids	mg/L	DG_A_I_PZ_BW28A	8/07/2020	14000
Total Dissolved Solids	mg/L	DG_A_I_PZ_BW53/Puls	9/07/2020	2010
Total Dissolved Solids	mg/L	DG_A_I_PZ_BW53/Puls	9/07/2020	1700
Total Dissolved Solids	mg/L	DG_A_I_PZ_GW05	9/07/2020	6030
Total Dissolved Solids	mg/L	DG_A_I_PZ_GW05	9/07/2020	5400
Total Dissolved Solids	mg/L	DG_A_I_PZ_GW04	9/07/2020	6365
Total Dissolved Solids	mg/L	DG_A_I_PZ_GW04	9/07/2020	5700
Total Dissolved Solids	mg/L	DG_A_I_PZ_WRK300	13/07/2020	4087
Total Dissolved Solids	mg/L	DG_A_I_PZ_WRK300	13/07/2020	3600
Total Dissolved Solids	mg/L	DG_A_I_PZ_WRK303	13/07/2020	6231
Total Dissolved Solids	mg/L	DG_A_I_PZ_WRK303	13/07/2020	5600
Total Dissolved Solids	mg/L	DG_A_I_PZ_WRK303	13/07/2020	6231
Total Dissolved Solids	mg/L	DG_A_I_PZ_WRK301	13/07/2020	7370
Total Dissolved Solids	mg/L	DG_A_I_PZ_WRK301	13/07/2020	7000
Total Dissolved Solids	mg/L	DG_A_I_PZ_WRK304	14/07/2020	5829
Total Dissolved Solids	mg/L	DG_A_I_PZ_WRK304	14/07/2020	5100
Total Dissolved Solids	mg/L	DG_A_I_PZ_GW04	10/08/2020	6164
Total Dissolved Solids	mg/L	DG_A_I_PZ_GW04	10/08/2020	5800
Total Dissolved Solids	mg/L	DG_A_I_PZ_BW28A	10/08/2020	14070

Variable	Unit	Sample Point	Date	Result
Total Dissolved Solids	mg/L	DG_A_I_PZ_BW28A	10/08/2020	14000
Total Dissolved Solids	mg/L	DG_A_I_PZ_GW02	10/08/2020	4891
Total Dissolved Solids	mg/L	DG_A_I_PZ_GW02	10/08/2020	4500
Total Dissolved Solids	mg/L	DG_A_I_PZ_GW01	10/08/2020	7370
Total Dissolved Solids	mg/L	DG_A_I_PZ_GW01	10/08/2020	6800
Total Dissolved Solids	mg/L	DG_A_I_PZ_GW04	10/08/2020	6164
Total Dissolved Solids	mg/L	DG_A_I_PZ_BW36A	17/08/2020	3500
Total Dissolved Solids	mg/L	DG_A_I_PZ_BW53/Puls	17/08/2020	1809
Total Dissolved Solids	mg/L	DG_A_I_PZ_BW53/Puls	17/08/2020	1600
Total Dissolved Solids	mg/L	DG_A_I_PZ_GW05	17/08/2020	5963
Total Dissolved Solids	mg/L	DG_A_I_PZ_GW05	17/08/2020	5200
Total Dissolved Solids	mg/L	DG_A_I_PZ_WRK303	19/08/2020	6365
Total Dissolved Solids	mg/L	DG_A_I_PZ_WRK303	19/08/2020	5600
Total Dissolved Solids	mg/L	DG_A_I_PZ_BW45B	19/08/2020	10720
Total Dissolved Solids	mg/L	DG_A_I_PZ_BW45B	19/08/2020	9900
Total Dissolved Solids	mg/L	DG_A_I_PZ_WRK304	19/08/2020	5762
Total Dissolved Solids	mg/L	DG_A_I_PZ_WRK304	19/08/2020	5000
Total Dissolved Solids	mg/L	DG_A_I_PZ_BW45B	19/08/2020	10720
Total Dissolved Solids	mg/L	DG_A_I_PZ_GW07	20/08/2020	12654.96
Total Dissolved Solids	mg/L	DG_A_I_PZ_GW03	20/08/2020	7847.71
Total Dissolved Solids	mg/L	DG_A_I_PZ_WRK300	20/08/2020	4366.39
Total Dissolved Solids	mg/L	DG_A_I_PZ_GW06	25/08/2020	14532.97
Total Dissolved Solids	mg/L	DG_A_I_PZ_GW08	25/08/2020	14482.72
Total Dissolved Solids	mg/L	DG_A_I_PZ_WRK302	25/08/2020	14077.37
Total Dissolved Solids	mg/L	DG_A_I_PZ_WRK301	25/08/2020	7649.39
Total Dissolved Solids	mg/L	DG_A_I_PZ_WRK302	3/09/2020	13400
Total Dissolved Solids	mg/L	DG_A_I_PZ_WRK302	3/09/2020	13000
Total Dissolved Solids	mg/L	DG_A_I_PZ_GW03	3/09/2020	7695.62
Total Dissolved Solids	mg/L	DG_A_I_PZ_GW02	3/09/2020	5202.55
Total Dissolved Solids	mg/L	DG_A_I_PZ_GW07	7/09/2020	12663
Total Dissolved Solids	mg/L	DG_A_I_PZ_GW05	7/09/2020	6403.19
Total Dissolved Solids	mg/L	DG_A_I_PZ_GW04	7/09/2020	6715.41
Total Dissolved Solids	mg/L	DG_A_I_PZ_GW01	7/09/2020	7811.53
Total Dissolved Solids	mg/L	DG_A_I_PZ_BW45B	7/09/2020	11696.19
Total Dissolved Solids	mg/L	DG_A_I_PZ_GW08	8/09/2020	14602.65
Total Dissolved Solids	mg/L	DG_A_I_PZ_GW06	8/09/2020	14577.19
Total Dissolved Solids	mg/L	DG_A_I_PZ_WRK300	8/09/2020	4385.15
Total Dissolved Solids	mg/L	DG_A_I_PZ_WRK304	9/09/2020	6956.61
Total Dissolved Solids	mg/L	DG_A_I_PZ_WRK303	9/09/2020	6523.12
Total Dissolved Solids	mg/L	DG_A_I_PZ_WRK301	9/09/2020	7815.55
Total Dissolved Solids	mg/L	DG_A_I_PZ_GW04	15/10/2020	6432
Total Dissolved Solids	mg/L	DG_A_I_PZ_GW04	15/10/2020	5600
Total Dissolved Solids	mg/L	DG_A_I_PZ_GW03	15/10/2020	7225.95
Total Dissolved Solids	mg/L	DG_A_I_PZ_GW02	15/10/2020	4858.84

Variable	Unit	Sample Point	Date	Result
Total Dissolved Solids	mg/L	DG_A_I_PZ_GW07	16/10/2020	11787.31
Total Dissolved Solids	mg/L	DG_A_I_PZ_GW01	16/10/2020	7269.5
Total Dissolved Solids	mg/L	DG_A_I_PZ_BW45B	16/10/2020	10969.91
Total Dissolved Solids	mg/L	DG_A_I_PZ_GW05	19/10/2020	5974.39
Total Dissolved Solids	mg/L	DG_A_I_PZ_WRK300	19/10/2020	4006.6
Total Dissolved Solids	mg/L	DG_A_I_PZ_GW08	19/10/2020	13587.6
Total Dissolved Solids	mg/L	DG_A_I_PZ_WRK302	19/10/2020	13093.14
Total Dissolved Solids	mg/L	DG_A_I_PZ_GW06	19/10/2020	13611.72
Total Dissolved Solids	mg/L	DG_A_I_PZ_WRK304	20/10/2020	6190.13
Total Dissolved Solids	mg/L	DG_A_I_PZ_WRK303	20/10/2020	6377.06
Total Dissolved Solids	mg/L	DG_A_I_PZ_WRK301	20/10/2020	6984.08
Total Dissolved Solids	mg/L	DG_A_I_PZ_GW07	24/11/2020	12596.67
Total Dissolved Solids	mg/L	DG_A_I_PZ_GW03	24/11/2020	7640.68
Total Dissolved Solids	mg/L	DG_A_I_PZ_GW02	24/11/2020	5209.25
Total Dissolved Solids	mg/L	DG_A_I_PZ_GW01	24/11/2020	7770.66
Total Dissolved Solids	mg/L	DG_A_I_PZ_BW45B	24/11/2020	11792
Total Dissolved Solids	mg/L	DG_A_I_PZ_GW04	25/11/2020	6724.79
Total Dissolved Solids	mg/L	DG_A_I_PZ_GW05	25/11/2020	6474.21
Total Dissolved Solids	mg/L	DG_A_I_PZ_WRK300	25/11/2020	4365.05
Total Dissolved Solids	mg/L	DG_A_I_PZ_GW08	26/11/2020	14395.62
Total Dissolved Solids	mg/L	DG_A_I_PZ_WRK302	26/11/2020	13984.91
Total Dissolved Solids	mg/L	DG_A_I_PZ_GW06	26/11/2020	14524.93
Total Dissolved Solids	mg/L	DG_A_I_PZ_GW04A	30/11/2020	4600
Total Dissolved Solids	mg/L	DG_A_I_PZ_WRK304	30/11/2020	6306.04
Total Dissolved Solids	mg/L	DG_A_I_PZ_WRK303	30/11/2020	6761.64
Total Dissolved Solids	mg/L	DG_A_I_PZ_WRK301	30/11/2020	8619.55
Total Dissolved Solids	mg/L	DG_A_I_PZ_GW05	4/12/2020	6324.13
Total Dissolved Solids	mg/L	DG_A_I_PZ_GW07	8/12/2020	12279.09
Total Dissolved Solids	mg/L	DG_A_I_PZ_GW03	8/12/2020	7512.71
Total Dissolved Solids	mg/L	DG_A_I_PZ_GW02	8/12/2020	5110.76
Total Dissolved Solids	mg/L	DG_A_I_PZ_BW45B	9/12/2020	11418.14
Total Dissolved Solids	mg/L	DG_A_I_PZ_GW01	9/12/2020	7531.47
Total Dissolved Solids	mg/L	DG_A_I_PZ_GW04	9/12/2020	6536.52
Total Dissolved Solids	mg/L	DG_A_I_PZ_GW08	10/12/2020	14190.6
Total Dissolved Solids	mg/L	DG_A_I_PZ_WRK302	10/12/2020	13570.18
Total Dissolved Solids	mg/L	DG_A_I_PZ_GW06	10/12/2020	14112.21
Total Dissolved Solids	mg/L	DG_A_I_PZ_WRK304	14/12/2020	6167.35
Total Dissolved Solids	mg/L	DG_A_I_PZ_WRK303	14/12/2020	6795.81
Total Dissolved Solids	mg/L	DG_A_I_PZ_WRK301	14/12/2020	7644.7
Total Dissolved Solids	mg/L	DG_A_I_PZ_WRK300	14/12/2020	4251.82
Total Dissolved Solids	mg/L	DG_A_I_PZ_GW04A	30/12/2020	4600
Uranium (Total)	mg/L	DG_A_I_PZ_GW07	2/07/2020	0.001
Uranium (Total)	mg/L	DG_A_I_PZ_GW03	2/07/2020	0.001
Uranium (Total)	mg/L	DG_A_I_PZ_GW02	2/07/2020	0.001

Variable	Unit	Sample Point	Date	Result
Uranium (Total)	mg/L	DG_A_I_PZ_GW08	6/07/2020	0.001
Uranium (Total)	mg/L	DG_A_I_PZ_WRK302	6/07/2020	0.001
Uranium (Total)	mg/L	DG_A_I_PZ_GW06	6/07/2020	0.003
Uranium (Total)	mg/L	DG_A_I_PZ_BW36A	7/07/2020	0.001
Uranium (Total)	mg/L	DG_A_I_PZ_GW01	7/07/2020	0.001
Uranium (Total)	mg/L	DG_A_I_PZ_BW45B	7/07/2020	0.017
Uranium (Total)	mg/L	DG_A_I_PZ_IWB2	8/07/2020	0.001
Uranium (Total)	mg/L	DG_A_I_PZ_IWB6	8/07/2020	0.001
Uranium (Total)	mg/L	DG_A_I_PZ_BW05	8/07/2020	0.004
Uranium (Total)	mg/L	DG_A_I_PZ_BW28A	8/07/2020	0.007
Uranium (Total)	mg/L	DG_A_I_PZ_BW53/Puls	9/07/2020	0.001
Uranium (Total)	mg/L	DG_A_I_PZ_GW05	9/07/2020	0.001
Uranium (Total)	mg/L	DG_A_I_PZ_GW04	9/07/2020	0.001
Uranium (Total)	mg/L	DG_A_I_PZ_WRK300	13/07/2020	0.001
Uranium (Total)	mg/L	DG_A_I_PZ_WRK303	13/07/2020	0.001
Uranium (Total)	mg/L	DG_A_I_PZ_WRK301	13/07/2020	0.006
Uranium (Total)	mg/L	DG_A_I_PZ_WRK304	14/07/2020	0.001
Uranium (Total)	mg/L	DG_A_I_PZ_GW04	10/08/2020	0.001
Uranium (Total)	mg/L	DG_A_I_PZ_BW28A	10/08/2020	0.007
Uranium (Total)	mg/L	DG_A_I_PZ_GW02	10/08/2020	0.001
Uranium (Total)	mg/L	DG_A_I_PZ_GW01	10/08/2020	0.001
Uranium (Total)	mg/L	DG_A_I_PZ_BW36A	17/08/2020	0.001
Uranium (Total)	mg/L	DG_A_I_PZ_BW53/Puls	17/08/2020	0.001
Uranium (Total)	mg/L	DG_A_I_PZ_GW05	17/08/2020	0.001
Uranium (Total)	mg/L	DG_A_I_PZ_WRK303	19/08/2020	0.004
Uranium (Total)	mg/L	DG_A_I_PZ_BW45B	19/08/2020	0.01
Uranium (Total)	mg/L	DG_A_I_PZ_WRK304	19/08/2020	0.004
Uranium (Total)	mg/L	DG_A_I_PZ_WRK302	3/09/2020	0.001
Uranium (Total)	mg/L	DG_A_I_PZ_GW04	15/10/2020	0.001
Uranium (Total)	mg/L	DG_A_I_PZ_GW04A	30/11/2020	0.001
Uranium (Total)	mg/L	DG_A_I_PZ_GW04A	30/12/2020	0.001
Uranium 238	Bq/L	DG_A_I_PZ_GW07	2/07/2020	0.123
Uranium 238	Bq/L	DG_A_I_PZ_GW03	2/07/2020	0.864
Uranium 238	Bq/L	DG_A_I_PZ_GW02	2/07/2020	0.025
Uranium 238	Bq/L	DG_A_I_PZ_GW08	6/07/2020	0.025
Uranium 238	Bq/L	DG_A_I_PZ_WRK302	6/07/2020	0.049
Uranium 238	Bq/L	DG_A_I_PZ_GW06	6/07/2020	0.667
Uranium 238	Bq/L	DG_A_I_PZ_BW36A	7/07/2020	0.025
Uranium 238	Bq/L	DG_A_I_PZ_GW01	7/07/2020	0.025
Uranium 238	Bq/L	DG_A_I_PZ_BW45B	7/07/2020	0.198
Uranium 238	Bq/L	DG_A_I_PZ_IWB2	8/07/2020	0.025
Uranium 238	Bq/L	DG_A_I_PZ_IWB6	8/07/2020	0.025
Uranium 238	Bq/L	DG_A_I_PZ_BW05	8/07/2020	0.025
Uranium 238	Bq/L	DG_A_I_PZ_BW28A	8/07/2020	0.025

Variable	Unit	Sample Point	Date	Result
Uranium 238	Bq/L	DG_A_I_PZ_BW53/Puls	9/07/2020	0.025
Uranium 238	Bq/L	DG_A_I_PZ_GW05	9/07/2020	0.025
Uranium 238	Bq/L	DG_A_I_PZ_GW04	9/07/2020	0.025
Uranium 238	Bq/L	DG_A_I_PZ_WRK300	13/07/2020	0.025
Uranium 238	Bq/L	DG_A_I_PZ_WRK303	13/07/2020	0.025
Uranium 238	Bq/L	DG_A_I_PZ_WRK301	13/07/2020	0.025
Uranium 238	Bq/L	DG_A_I_PZ_WRK304	14/07/2020	0.025
Uranium 238	Bq/L	DG_A_I_PZ_BW28A	10/08/2020	0.148
Uranium 238	Bq/L	DG_A_I_PZ_GW02	10/08/2020	0.025
Uranium 238	Bq/L	DG_A_I_PZ_GW01	10/08/2020	0.025
Uranium 238	Bq/L	DG_A_I_PZ_GW04	10/08/2020	0.025
Uranium 238	Bq/L	DG_A_I_PZ_BW53/Puls	17/08/2020	0.037
Uranium 238	Bq/L	DG_A_I_PZ_GW05	17/08/2020	0.025
Uranium 238	Bq/L	DG_A_I_PZ_BW36A	17/08/2020	0.037
Uranium 238	Bq/L	DG_A_I_PZ_WRK303	19/08/2020	0.025
Uranium 238	Bq/L	DG_A_I_PZ_WRK304	19/08/2020	0.025
Uranium 238	Bq/L	DG_A_I_PZ_BW45B	19/08/2020	0.025
Uranium 238	Bq/L	DG_A_I_PZ_WRK302	3/09/2020	0.16
Uranium 238	Bq/L	DG_A_I_PZ_GW04	15/10/2020	0.025
Uranium 238	Bq/L	DG_A_I_PZ_GW04A	30/11/2020	0.025
Vanadium (Total)	mg/L	DG_A_I_PZ_GW07	2/07/2020	0.006
Vanadium (Total)	mg/L	DG_A_I_PZ_GW03	2/07/2020	0.009
Vanadium (Total)	mg/L	DG_A_I_PZ_GW02	2/07/2020	0.01
Vanadium (Total)	mg/L	DG_A_I_PZ_GW08	6/07/2020	0.011
Vanadium (Total)	mg/L	DG_A_I_PZ_WRK302	6/07/2020	0.001
Vanadium (Total)	mg/L	DG_A_I_PZ_GW06	6/07/2020	0.007
Vanadium (Total)	mg/L	DG_A_I_PZ_BW36A	7/07/2020	0.003
Vanadium (Total)	mg/L	DG_A_I_PZ_GW01	7/07/2020	0.004
Vanadium (Total)	mg/L	DG_A_I_PZ_BW45B	7/07/2020	0.004
Vanadium (Total)	mg/L	DG_A_I_PZ_IWB2	8/07/2020	0.002
Vanadium (Total)	mg/L	DG_A_I_PZ_IWB6	8/07/2020	0.006
Vanadium (Total)	mg/L	DG_A_I_PZ_BW05	8/07/2020	0.005
Vanadium (Total)	mg/L	DG_A_I_PZ_BW28A	8/07/2020	0.003
Vanadium (Total)	mg/L	DG_A_I_PZ_BW53/Puls	9/07/2020	0.012
Vanadium (Total)	mg/L	DG_A_I_PZ_GW05	9/07/2020	0.005
Vanadium (Total)	mg/L	DG_A_I_PZ_GW04	9/07/2020	0.004
Vanadium (Total)	mg/L	DG_A_I_PZ_WRK300	13/07/2020	0.003
Vanadium (Total)	mg/L	DG_A_I_PZ_WRK303	13/07/2020	0.002
Vanadium (Total)	mg/L	DG_A_I_PZ_WRK301	13/07/2020	0.007
Vanadium (Total)	mg/L	DG_A_I_PZ_WRK304	14/07/2020	0.001
Vanadium (Total)	mg/L	DG_A_I_PZ_GW04	10/08/2020	0.002
Vanadium (Total)	mg/L	DG_A_I_PZ_BW28A	10/08/2020	0.001
Vanadium (Total)	mg/L	DG_A_I_PZ_GW02	10/08/2020	0.001
Vanadium (Total)	mg/L	DG_A_I_PZ_GW01	10/08/2020	0.004

Variable	Unit	Sample Point	Date	Result
Vanadium (Total)	mg/L	DG_A_I_PZ_BW36A	17/08/2020	0.002
Vanadium (Total)	mg/L	DG_A_I_PZ_BW53/Puls	17/08/2020	0.015
Vanadium (Total)	mg/L	DG_A_I_PZ_GW05	17/08/2020	0.003
Vanadium (Total)	mg/L	DG_A_I_PZ_WRK303	19/08/2020	0.001
Vanadium (Total)	mg/L	DG_A_I_PZ_BW45B	19/08/2020	0.001
Vanadium (Total)	mg/L	DG_A_I_PZ_WRK304	19/08/2020	0.002
Vanadium (Total)	mg/L	DG_A_I_PZ_WRK302	3/09/2020	0.001
Vanadium (Total)	mg/L	DG_A_I_PZ_GW04	15/10/2020	0.001
Vanadium (Total)	mg/L	DG_A_I_PZ_GW04A	30/11/2020	0.003
Vanadium (Total)	mg/L	DG_A_I_PZ_GW04A	30/12/2020	0.003
Zinc (Total)	mg/L	DG_A_I_PZ_GW07	2/07/2020	0.011
Zinc (Total)	mg/L	DG_A_I_PZ_GW03	2/07/2020	0.039
Zinc (Total)	mg/L	DG_A_I_PZ_GW02	2/07/2020	0.016
Zinc (Total)	mg/L	DG_A_I_PZ_GW08	6/07/2020	0.013
Zinc (Total)	mg/L	DG_A_I_PZ_WRK302	6/07/2020	0.003
Zinc (Total)	mg/L	DG_A_I_PZ_GW06	6/07/2020	0.001
Zinc (Total)	mg/L	DG_A_I_PZ_BW36A	7/07/2020	0.013
Zinc (Total)	mg/L	DG_A_I_PZ_GW01	7/07/2020	0.034
Zinc (Total)	mg/L	DG_A_I_PZ_BW45B	7/07/2020	0.047
Zinc (Total)	mg/L	DG_A_I_PZ_IWB2	8/07/2020	0.005
Zinc (Total)	mg/L	DG_A_I_PZ_IWB6	8/07/2020	0.004
Zinc (Total)	mg/L	DG_A_I_PZ_BW05	8/07/2020	0.009
Zinc (Total)	mg/L	DG_A_I_PZ_BW28A	8/07/2020	0.016
Zinc (Total)	mg/L	DG_A_I_PZ_BW53/Puls	9/07/2020	0.014
Zinc (Total)	mg/L	DG_A_I_PZ_GW05	9/07/2020	0.028
Zinc (Total)	mg/L	DG_A_I_PZ_GW04	9/07/2020	0.022
Zinc (Total)	mg/L	DG_A_I_PZ_WRK300	13/07/2020	0.015
Zinc (Total)	mg/L	DG_A_I_PZ_WRK303	13/07/2020	0.015
Zinc (Total)	mg/L	DG_A_I_PZ_WRK301	13/07/2020	0.012
Zinc (Total)	mg/L	DG_A_I_PZ_WRK304	14/07/2020	0.013
Zinc (Total)	mg/L	DG_A_I_PZ_GW04	10/08/2020	0.014
Zinc (Total)	mg/L	DG_A_I_PZ_BW28A	10/08/2020	0.012
Zinc (Total)	mg/L	DG_A_I_PZ_GW02	10/08/2020	0.014
Zinc (Total)	mg/L	DG_A_I_PZ_GW01	10/08/2020	0.019
Zinc (Total)	mg/L	DG_A_I_PZ_BW36A	17/08/2020	0.011
Zinc (Total)	mg/L	DG_A_I_PZ_BW53/Puls	17/08/2020	0.039
Zinc (Total)	mg/L	DG_A_I_PZ_GW05	17/08/2020	0.018
Zinc (Total)	mg/L	DG_A_I_PZ_WRK303	19/08/2020	0.011
Zinc (Total)	mg/L	DG_A_I_PZ_BW45B	19/08/2020	0.037
Zinc (Total)	mg/L	DG_A_I_PZ_WRK304	19/08/2020	0.012
Zinc (Total)	mg/L	DG_A_I_PZ_WRK302	3/09/2020	0.012
Zinc (Total)	mg/L	DG_A_I_PZ_GW04	15/10/2020	0.029
Zinc (Total)	mg/L	DG_A_I_PZ_GW04A	30/11/2020	0.016
Zinc (Total)	mg/L	DG_A_I_PZ_GW04A	30/12/2020	0.016

Appendix C: Monitoring Data (Field) – Groundwater

Variable	Unit	Sample Point	Date	Result
Dissolved Oxygen	mg/L	DG_A_I_PZ_BW28A	8/07/2020	0
Dissolved Oxygen	mg/L	DG_A_I_PZ_BW28A	10/08/2020	0
Dissolved Oxygen	mg/L	DG_A_I_PZ_BW53/Puls	9/07/2020	0.5
Dissolved Oxygen	mg/L	DG_A_I_PZ_BW53/Puls	17/08/2020	0.2
Dissolved Oxygen	mg/L	DG_A_I_PZ_BW05	8/07/2020	0
Dissolved Oxygen	mg/L	DG_A_I_PZ_IWB2	8/07/2020	0
Dissolved Oxygen	mg/L	DG_A_I_PZ_IWB6	8/07/2020	3.3
Dissolved Oxygen	mg/L	DG_A_I_PZ_WRK300	13/07/2020	1
Dissolved Oxygen	mg/L	DG_A_I_PZ_WRK300	20/08/2020	0.3
Dissolved Oxygen	mg/L	DG_A_I_PZ_WRK300	8/09/2020	1
Dissolved Oxygen	mg/L	DG_A_I_PZ_WRK300	19/10/2020	2.1
Dissolved Oxygen	mg/L	DG_A_I_PZ_WRK300	25/11/2020	1.4
Dissolved Oxygen	mg/L	DG_A_I_PZ_WRK300	14/12/2020	2.5
Dissolved Oxygen	mg/L	DG_A_I_PZ_WRK301	13/07/2020	0.9
Dissolved Oxygen	mg/L	DG_A_I_PZ_WRK301	25/08/2020	1.2
Dissolved Oxygen	mg/L	DG_A_I_PZ_WRK301	9/09/2020	1.4
Dissolved Oxygen	mg/L	DG_A_I_PZ_WRK301	20/10/2020	1
Dissolved Oxygen	mg/L	DG_A_I_PZ_WRK301	30/11/2020	1
Dissolved Oxygen	mg/L	DG_A_I_PZ_WRK301	14/12/2020	6.7
Dissolved Oxygen	mg/L	DG_A_I_PZ_WRK302	6/07/2020	6.6
Dissolved Oxygen	mg/L	DG_A_I_PZ_WRK302	25/08/2020	6.4
Dissolved Oxygen	mg/L	DG_A_I_PZ_WRK302	3/09/2020	6.4
Dissolved Oxygen	mg/L	DG_A_I_PZ_WRK302	19/10/2020	6.2
Dissolved Oxygen	mg/L	DG_A_I_PZ_WRK302	26/11/2020	6.1
Dissolved Oxygen	mg/L	DG_A_I_PZ_WRK302	10/12/2020	6.8
Dissolved Oxygen	mg/L	DG_A_I_PZ_WRK303	13/07/2020	7.8
Dissolved Oxygen	mg/L	DG_A_I_PZ_WRK303	19/08/2020	9.1
Dissolved Oxygen	mg/L	DG_A_I_PZ_WRK303	9/09/2020	4.7
Dissolved Oxygen	mg/L	DG_A_I_PZ_WRK303	20/10/2020	9.3
Dissolved Oxygen	mg/L	DG_A_I_PZ_WRK303	30/11/2020	7
Dissolved Oxygen	mg/L	DG_A_I_PZ_WRK303	14/12/2020	8.1
Dissolved Oxygen	mg/L	DG_A_I_PZ_WRK304	14/07/2020	9.6
Dissolved Oxygen	mg/L	DG_A_I_PZ_WRK304	19/08/2020	9.7
Dissolved Oxygen	mg/L	DG_A_I_PZ_WRK304	9/09/2020	9.7
Dissolved Oxygen	mg/L	DG_A_I_PZ_WRK304	20/10/2020	9.8
Dissolved Oxygen	mg/L	DG_A_I_PZ_WRK304	30/11/2020	10.2
Dissolved Oxygen	mg/L	DG_A_I_PZ_WRK304	14/12/2020	8
Dissolved Oxygen	mg/L	DG_A_I_PZ_GW01	7/07/2020	4.6
Dissolved Oxygen	mg/L	DG_A_I_PZ_GW01	10/08/2020	4.7
Dissolved Oxygen	mg/L	DG_A_I_PZ_GW01	7/09/2020	4.6
Dissolved Oxygen	mg/L	DG_A_I_PZ_GW01	16/10/2020	4.6
Dissolved Oxygen	mg/L	DG_A_I_PZ_GW01	24/11/2020	5

Variable	Unit	Sample Point	Date	Result
Dissolved Oxygen	mg/L	DG_A_I_PZ_GW01	9/12/2020	5.4
Dissolved Oxygen	mg/L	DG_A_I_PZ_GW06	6/07/2020	8.7
Dissolved Oxygen	mg/L	DG_A_I_PZ_GW06	25/08/2020	7.6
Dissolved Oxygen	mg/L	DG_A_I_PZ_GW06	8/09/2020	8.4
Dissolved Oxygen	mg/L	DG_A_I_PZ_GW06	19/10/2020	8.3
Dissolved Oxygen	mg/L	DG_A_I_PZ_GW06	26/11/2020	8.3
Dissolved Oxygen	mg/L	DG_A_I_PZ_GW06	10/12/2020	6.8
Dissolved Oxygen	mg/L	DG_A_I_PZ_GW07	2/07/2020	9.3
Dissolved Oxygen	mg/L	DG_A_I_PZ_GW07	20/08/2020	8
Dissolved Oxygen	mg/L	DG_A_I_PZ_GW07	7/09/2020	7.7
Dissolved Oxygen	mg/L	DG_A_I_PZ_GW07	16/10/2020	7.7
Dissolved Oxygen	mg/L	DG_A_I_PZ_GW07	24/11/2020	7.6
Dissolved Oxygen	mg/L	DG_A_I_PZ_GW07	8/12/2020	7.8
Dissolved Oxygen	mg/L	DG_A_I_PZ_BW45B	7/07/2020	0.2
Dissolved Oxygen	mg/L	DG_A_I_PZ_BW45B	19/08/2020	1
Dissolved Oxygen	mg/L	DG_A_I_PZ_BW45B	7/09/2020	5
Dissolved Oxygen	mg/L	DG_A_I_PZ_BW45B	16/10/2020	0.3
Dissolved Oxygen	mg/L	DG_A_I_PZ_BW45B	24/11/2020	1
Dissolved Oxygen	mg/L	DG_A_I_PZ_BW45B	9/12/2020	1.2
Dissolved Oxygen	mg/L	DG_A_I_PZ_GW02	2/07/2020	2.3
Dissolved Oxygen	mg/L	DG_A_I_PZ_GW02	10/08/2020	0.7
Dissolved Oxygen	mg/L	DG_A_I_PZ_GW02	3/09/2020	0
Dissolved Oxygen	mg/L	DG_A_I_PZ_GW02	15/10/2020	0.8
Dissolved Oxygen	mg/L	DG_A_I_PZ_GW02	24/11/2020	0.7
Dissolved Oxygen	mg/L	DG_A_I_PZ_GW02	8/12/2020	0.6
Dissolved Oxygen	mg/L	DG_A_I_PZ_GW03	2/07/2020	0.1
Dissolved Oxygen	mg/L	DG_A_I_PZ_GW03	20/08/2020	0.6
Dissolved Oxygen	mg/L	DG_A_I_PZ_GW03	3/09/2020	1
Dissolved Oxygen	mg/L	DG_A_I_PZ_GW03	15/10/2020	1.3
Dissolved Oxygen	mg/L	DG_A_I_PZ_GW03	24/11/2020	3.9
Dissolved Oxygen	mg/L	DG_A_I_PZ_GW03	8/12/2020	4.8
Dissolved Oxygen	mg/L	DG_A_I_PZ_GW04	9/07/2020	6.4
Dissolved Oxygen	mg/L	DG_A_I_PZ_GW04	10/08/2020	6.3
Dissolved Oxygen	mg/L	DG_A_I_PZ_GW04	7/09/2020	6.9
Dissolved Oxygen	mg/L	DG_A_I_PZ_GW04	15/10/2020	6.8
Dissolved Oxygen	mg/L	DG_A_I_PZ_GW04	25/11/2020	7
Dissolved Oxygen	mg/L	DG_A_I_PZ_GW04	9/12/2020	8
Dissolved Oxygen	mg/L	DG_A_I_PZ_GW05	9/07/2020	0.5
Dissolved Oxygen	mg/L	DG_A_I_PZ_GW05	17/08/2020	0.3
Dissolved Oxygen	mg/L	DG_A_I_PZ_GW05	7/09/2020	0.3
Dissolved Oxygen	mg/L	DG_A_I_PZ_GW05	19/10/2020	0.3
Dissolved Oxygen	mg/L	DG_A_I_PZ_GW05	25/11/2020	0.7
Dissolved Oxygen	mg/L	DG_A_I_PZ_GW05	4/12/2020	0
Dissolved Oxygen	mg/L	DG_A_I_PZ_GW08	6/07/2020	5.6

Variable	Unit	Sample Point	Date	Result
Dissolved Oxygen	mg/L	DG_A_I_PZ_GW08	25/08/2020	7.4
Dissolved Oxygen	mg/L	DG_A_I_PZ_GW08	8/09/2020	8
Dissolved Oxygen	mg/L	DG_A_I_PZ_GW08	19/10/2020	6.8
Dissolved Oxygen	mg/L	DG_A_I_PZ_GW08	26/11/2020	7.2
Dissolved Oxygen	mg/L	DG_A_I_PZ_GW08	10/12/2020	7
Dissolved Oxygen	mg/L	DG_A_I_PZ_BW36A	7/07/2020	0.1
Dissolved Oxygen	mg/L	DG_A_I_PZ_BW36A	17/08/2020	0
Dissolved Oxygen	mg/L	DG_A_I_PZ_BW36A	7/09/2020	1
Dissolved Oxygen	mg/L	DG_A_I_PZ_BW36A	19/10/2020	0
Dissolved Oxygen	mg/L	DG_A_I_PZ_BW36A	25/11/2020	1
Dissolved Oxygen	mg/L	DG_A_I_PZ_BW36A	9/12/2020	0
Dissolved Oxygen	mg/L	DG_A_I_PZ_GW04A	30/11/2020	4.3
Dissolved Oxygen	mg/L	DG_A_I_PZ_GW04A	10/12/2020	3
Dissolved Oxygen Field	%	DG_A_I_PZ_BW28A	8/07/2020	0
Dissolved Oxygen Field	%	DG_A_I_PZ_BW28A	10/08/2020	0
Dissolved Oxygen Field	%	DG_A_I_PZ_BW53/Puls	9/07/2020	4
Dissolved Oxygen Field	%	DG_A_I_PZ_BW53/Puls	17/08/2020	5
Dissolved Oxygen Field	%	DG_A_I_PZ_BW05	8/07/2020	0
Dissolved Oxygen Field	%	DG_A_I_PZ_IWB2	8/07/2020	0
Dissolved Oxygen Field	%	DG_A_I_PZ_IWB6	8/07/2020	35
Dissolved Oxygen Field	%	DG_A_I_PZ_WRK300	13/07/2020	9
Dissolved Oxygen Field	%	DG_A_I_PZ_WRK300	20/08/2020	4
Dissolved Oxygen Field	%	DG_A_I_PZ_WRK300	8/09/2020	18
Dissolved Oxygen Field	%	DG_A_I_PZ_WRK300	19/10/2020	28
Dissolved Oxygen Field	%	DG_A_I_PZ_WRK300	25/11/2020	23
Dissolved Oxygen Field	%	DG_A_I_PZ_WRK300	14/12/2020	30
Dissolved Oxygen Field	%	DG_A_I_PZ_WRK301	13/07/2020	10
Dissolved Oxygen Field	%	DG_A_I_PZ_WRK301	25/08/2020	13
Dissolved Oxygen Field	%	DG_A_I_PZ_WRK301	9/09/2020	14
Dissolved Oxygen Field	%	DG_A_I_PZ_WRK301	20/10/2020	9
Dissolved Oxygen Field	%	DG_A_I_PZ_WRK301	30/11/2020	11
Dissolved Oxygen Field	%	DG_A_I_PZ_WRK301	14/12/2020	56
Dissolved Oxygen Field	%	DG_A_I_PZ_WRK302	6/07/2020	74
Dissolved Oxygen Field	%	DG_A_I_PZ_WRK302	25/08/2020	72
Dissolved Oxygen Field	%	DG_A_I_PZ_WRK302	3/09/2020	73
Dissolved Oxygen Field	%	DG_A_I_PZ_WRK302	19/10/2020	70
Dissolved Oxygen Field	%	DG_A_I_PZ_WRK302	26/11/2020	70
Dissolved Oxygen Field	%	DG_A_I_PZ_WRK302	10/12/2020	77
Dissolved Oxygen Field	%	DG_A_I_PZ_WRK303	13/07/2020	81
Dissolved Oxygen Field	%	DG_A_I_PZ_WRK303	19/08/2020	105
Dissolved Oxygen Field	%	DG_A_I_PZ_WRK303	9/09/2020	48
Dissolved Oxygen Field	%	DG_A_I_PZ_WRK303	20/10/2020	106
Dissolved Oxygen Field	%	DG_A_I_PZ_WRK303	30/11/2020	82
Dissolved Oxygen Field	%	DG_A_I_PZ_WRK303	14/12/2020	78

Variable	Unit	Sample Point	Date	Result
Dissolved Oxygen Field	%	DG_A_I_PZ_WRK304	14/07/2020	101
Dissolved Oxygen Field	%	DG_A_I_PZ_WRK304	19/08/2020	100
Dissolved Oxygen Field	%	DG_A_I_PZ_WRK304	9/09/2020	101
Dissolved Oxygen Field	%	DG_A_I_PZ_WRK304	20/10/2020	106
Dissolved Oxygen Field	%	DG_A_I_PZ_WRK304	30/11/2020	115
Dissolved Oxygen Field	%	DG_A_I_PZ_WRK304	14/12/2020	103
Dissolved Oxygen Field	%	DG_A_I_PZ_GW01	7/07/2020	47
Dissolved Oxygen Field	%	DG_A_I_PZ_GW01	10/08/2020	45
Dissolved Oxygen Field	%	DG_A_I_PZ_GW01	7/09/2020	54
Dissolved Oxygen Field	%	DG_A_I_PZ_GW01	16/10/2020	51
Dissolved Oxygen Field	%	DG_A_I_PZ_GW01	24/11/2020	59
Dissolved Oxygen Field	%	DG_A_I_PZ_GW01	9/12/2020	54
Dissolved Oxygen Field	%	DG_A_I_PZ_GW06	6/07/2020	92
Dissolved Oxygen Field	%	DG_A_I_PZ_GW06	25/08/2020	89
Dissolved Oxygen Field	%	DG_A_I_PZ_GW06	8/09/2020	96
Dissolved Oxygen Field	%	DG_A_I_PZ_GW06	19/10/2020	95
Dissolved Oxygen Field	%	DG_A_I_PZ_GW06	26/11/2020	87
Dissolved Oxygen Field	%	DG_A_I_PZ_GW06	10/12/2020	79
Dissolved Oxygen Field	%	DG_A_I_PZ_GW07	2/07/2020	95
Dissolved Oxygen Field	%	DG_A_I_PZ_GW07	20/08/2020	94
Dissolved Oxygen Field	%	DG_A_I_PZ_GW07	7/09/2020	88
Dissolved Oxygen Field	%	DG_A_I_PZ_GW07	16/10/2020	88
Dissolved Oxygen Field	%	DG_A_I_PZ_GW07	24/11/2020	88
Dissolved Oxygen Field	%	DG_A_I_PZ_GW07	8/12/2020	102
Dissolved Oxygen Field	%	DG_A_I_PZ_BW45B	7/07/2020	4
Dissolved Oxygen Field	%	DG_A_I_PZ_BW45B	19/08/2020	10
Dissolved Oxygen Field	%	DG_A_I_PZ_BW45B	7/09/2020	0.3
Dissolved Oxygen Field	%	DG_A_I_PZ_BW45B	16/10/2020	3
Dissolved Oxygen Field	%	DG_A_I_PZ_BW45B	24/11/2020	9
Dissolved Oxygen Field	%	DG_A_I_PZ_BW45B	9/12/2020	14
Dissolved Oxygen Field	%	DG_A_I_PZ_GW02	2/07/2020	30
Dissolved Oxygen Field	%	DG_A_I_PZ_GW02	10/08/2020	6
Dissolved Oxygen Field	%	DG_A_I_PZ_GW02	3/09/2020	0
Dissolved Oxygen Field	%	DG_A_I_PZ_GW02	15/10/2020	10
Dissolved Oxygen Field	%	DG_A_I_PZ_GW02	24/11/2020	9
Dissolved Oxygen Field	%	DG_A_I_PZ_GW02	8/12/2020	7
Dissolved Oxygen Field	%	DG_A_I_PZ_GW03	2/07/2020	9
Dissolved Oxygen Field	%	DG_A_I_PZ_GW03	20/08/2020	3
Dissolved Oxygen Field	%	DG_A_I_PZ_GW03	3/09/2020	7
Dissolved Oxygen Field	%	DG_A_I_PZ_GW03	15/10/2020	12
Dissolved Oxygen Field	%	DG_A_I_PZ_GW03	24/11/2020	42
Dissolved Oxygen Field	%	DG_A_I_PZ_GW03	8/12/2020	52
Dissolved Oxygen Field	%	DG_A_I_PZ_GW04	9/07/2020	61
Dissolved Oxygen Field	%	DG_A_I_PZ_GW04	10/08/2020	60

Variable	Unit	Sample Point	Date	Result
Dissolved Oxygen Field	%	DG_A_I_PZ_GW04	7/09/2020	78
Dissolved Oxygen Field	%	DG_A_I_PZ_GW04	15/10/2020	76
Dissolved Oxygen Field	%	DG_A_I_PZ_GW04	25/11/2020	86
Dissolved Oxygen Field	%	DG_A_I_PZ_GW04	9/12/2020	95
Dissolved Oxygen Field	%	DG_A_I_PZ_GW05	9/07/2020	2
Dissolved Oxygen Field	%	DG_A_I_PZ_GW05	17/08/2020	3
Dissolved Oxygen Field	%	DG_A_I_PZ_GW05	7/09/2020	4
Dissolved Oxygen Field	%	DG_A_I_PZ_GW05	19/10/2020	5
Dissolved Oxygen Field	%	DG_A_I_PZ_GW05	25/11/2020	8
Dissolved Oxygen Field	%	DG_A_I_PZ_GW05	4/12/2020	0
Dissolved Oxygen Field	%	DG_A_I_PZ_GW08	6/07/2020	59
Dissolved Oxygen Field	%	DG_A_I_PZ_GW08	25/08/2020	84
Dissolved Oxygen Field	%	DG_A_I_PZ_GW08	8/09/2020	92
Dissolved Oxygen Field	%	DG_A_I_PZ_GW08	19/10/2020	79
Dissolved Oxygen Field	%	DG_A_I_PZ_GW08	26/11/2020	74
Dissolved Oxygen Field	%	DG_A_I_PZ_GW08	10/12/2020	77
Dissolved Oxygen Field	%	DG_A_I_PZ_BW36A	7/07/2020	9
Dissolved Oxygen Field	%	DG_A_I_PZ_BW36A	17/08/2020	0
Dissolved Oxygen Field	%	DG_A_I_PZ_BW36A	7/09/2020	0.1
Dissolved Oxygen Field	%	DG_A_I_PZ_BW36A	19/10/2020	0
Dissolved Oxygen Field	%	DG_A_I_PZ_BW36A	25/11/2020	0.2
Dissolved Oxygen Field	%	DG_A_I_PZ_BW36A	9/12/2020	0
Dissolved Oxygen Field	%	DG_A_I_PZ_GW04A	30/11/2020	39
Dissolved Oxygen Field	%	DG_A_I_PZ_GW04A	10/12/2020	27
Electrical Conductivity	µS/cm	DG_A_I_PZ_BW28A	8/07/2020	21000
Electrical Conductivity	µS/cm	DG_A_I_PZ_BW28A	10/08/2020	21000
Electrical Conductivity	µS/cm	DG_A_I_PZ_BW53/Puls	9/07/2020	3000
Electrical Conductivity	µS/cm	DG_A_I_PZ_BW53/Puls	17/08/2020	2700
Electrical Conductivity	µS/cm	DG_A_I_PZ_BW05	8/07/2020	23000
Electrical Conductivity	µS/cm	DG_A_I_PZ_IWB2	8/07/2020	4000
Electrical Conductivity	µS/cm	DG_A_I_PZ_IWB6	8/07/2020	1700
Electrical Conductivity	µS/cm	DG_A_I_PZ_WRK300	13/07/2020	6100
Electrical Conductivity	µS/cm	DG_A_I_PZ_WRK300	20/08/2020	6517
Electrical Conductivity	µS/cm	DG_A_I_PZ_WRK300	8/09/2020	6545
Electrical Conductivity	µS/cm	DG_A_I_PZ_WRK300	19/10/2020	5980
Electrical Conductivity	µS/cm	DG_A_I_PZ_WRK300	25/11/2020	6515
Electrical Conductivity	µS/cm	DG_A_I_PZ_WRK300	14/12/2020	6346
Electrical Conductivity	µS/cm	DG_A_I_PZ_WRK301	13/07/2020	11000
Electrical Conductivity	µS/cm	DG_A_I_PZ_WRK301	25/08/2020	11417
Electrical Conductivity	µS/cm	DG_A_I_PZ_WRK301	9/09/2020	11665
Electrical Conductivity	µS/cm	DG_A_I_PZ_WRK301	20/10/2020	10424
Electrical Conductivity	µS/cm	DG_A_I_PZ_WRK301	30/11/2020	12865
Electrical Conductivity	µS/cm	DG_A_I_PZ_WRK301	14/12/2020	11410
Electrical Conductivity	µS/cm	DG_A_I_PZ_WRK302	6/07/2020	20000

Variable	Unit	Sample Point	Date	Result
Electrical Conductivity	µS/cm	DG_A_I_PZ_WRK302	25/08/2020	21011
Electrical Conductivity	µS/cm	DG_A_I_PZ_WRK302	3/09/2020	20000
Electrical Conductivity	µS/cm	DG_A_I_PZ_WRK302	19/10/2020	19542
Electrical Conductivity	µS/cm	DG_A_I_PZ_WRK302	26/11/2020	20873
Electrical Conductivity	µS/cm	DG_A_I_PZ_WRK302	10/12/2020	20254
Electrical Conductivity	µS/cm	DG_A_I_PZ_WRK303	13/07/2020	9300
Electrical Conductivity	µS/cm	DG_A_I_PZ_WRK303	19/08/2020	9500
Electrical Conductivity	µS/cm	DG_A_I_PZ_WRK303	9/09/2020	9736
Electrical Conductivity	µS/cm	DG_A_I_PZ_WRK303	20/10/2020	9518
Electrical Conductivity	µS/cm	DG_A_I_PZ_WRK303	30/11/2020	10092
Electrical Conductivity	µS/cm	DG_A_I_PZ_WRK303	14/12/2020	10143
Electrical Conductivity	µS/cm	DG_A_I_PZ_WRK304	14/07/2020	8700
Electrical Conductivity	µS/cm	DG_A_I_PZ_WRK304	19/08/2020	8600
Electrical Conductivity	µS/cm	DG_A_I_PZ_WRK304	9/09/2020	10383
Electrical Conductivity	µS/cm	DG_A_I_PZ_WRK304	20/10/2020	9239
Electrical Conductivity	µS/cm	DG_A_I_PZ_WRK304	30/11/2020	9412
Electrical Conductivity	µS/cm	DG_A_I_PZ_WRK304	14/12/2020	9205
Electrical Conductivity	µS/cm	DG_A_I_PZ_GW01	7/07/2020	11000
Electrical Conductivity	µS/cm	DG_A_I_PZ_GW01	10/08/2020	11000
Electrical Conductivity	µS/cm	DG_A_I_PZ_GW01	7/09/2020	11659
Electrical Conductivity	µS/cm	DG_A_I_PZ_GW01	16/10/2020	10850
Electrical Conductivity	µS/cm	DG_A_I_PZ_GW01	24/11/2020	11598
Electrical Conductivity	µS/cm	DG_A_I_PZ_GW01	9/12/2020	11241
Electrical Conductivity	µS/cm	DG_A_I_PZ_GW06	6/07/2020	20000
Electrical Conductivity	µS/cm	DG_A_I_PZ_GW06	25/08/2020	21691
Electrical Conductivity	µS/cm	DG_A_I_PZ_GW06	8/09/2020	21757
Electrical Conductivity	µS/cm	DG_A_I_PZ_GW06	19/10/2020	20316
Electrical Conductivity	µS/cm	DG_A_I_PZ_GW06	26/11/2020	21679
Electrical Conductivity	µS/cm	DG_A_I_PZ_GW06	10/12/2020	21063
Electrical Conductivity	µS/cm	DG_A_I_PZ_GW07	2/07/2020	17000
Electrical Conductivity	µS/cm	DG_A_I_PZ_GW07	20/08/2020	18888
Electrical Conductivity	µS/cm	DG_A_I_PZ_GW07	7/09/2020	18900
Electrical Conductivity	µS/cm	DG_A_I_PZ_GW07	16/10/2020	17593
Electrical Conductivity	µS/cm	DG_A_I_PZ_GW07	24/11/2020	18801
Electrical Conductivity	µS/cm	DG_A_I_PZ_GW07	8/12/2020	18327
Electrical Conductivity	µS/cm	DG_A_I_PZ_BW45B	7/07/2020	16000
Electrical Conductivity	µS/cm	DG_A_I_PZ_BW45B	19/08/2020	16000
Electrical Conductivity	µS/cm	DG_A_I_PZ_BW45B	7/09/2020	17457
Electrical Conductivity	µS/cm	DG_A_I_PZ_BW45B	16/10/2020	16373
Electrical Conductivity	µS/cm	DG_A_I_PZ_BW45B	24/11/2020	17600
Electrical Conductivity	µS/cm	DG_A_I_PZ_BW45B	9/12/2020	17042
Electrical Conductivity	µS/cm	DG_A_I_PZ_GW02	2/07/2020	7300
Electrical Conductivity	µS/cm	DG_A_I_PZ_GW02	10/08/2020	7300
Electrical Conductivity	µS/cm	DG_A_I_PZ_GW02	3/09/2020	7765

Variable	Unit	Sample Point	Date	Result
Electrical Conductivity	µS/cm	DG_A_I_PZ_GW02	15/10/2020	7252
Electrical Conductivity	µS/cm	DG_A_I_PZ_GW02	24/11/2020	7775
Electrical Conductivity	µS/cm	DG_A_I_PZ_GW02	8/12/2020	7628
Electrical Conductivity	µS/cm	DG_A_I_PZ_GW03	2/07/2020	11000
Electrical Conductivity	µS/cm	DG_A_I_PZ_GW03	20/08/2020	11713
Electrical Conductivity	µS/cm	DG_A_I_PZ_GW03	3/09/2020	11486
Electrical Conductivity	µS/cm	DG_A_I_PZ_GW03	15/10/2020	10785
Electrical Conductivity	µS/cm	DG_A_I_PZ_GW03	24/11/2020	11404
Electrical Conductivity	µS/cm	DG_A_I_PZ_GW03	8/12/2020	11213
Electrical Conductivity	µS/cm	DG_A_I_PZ_GW04	9/07/2020	9500
Electrical Conductivity	µS/cm	DG_A_I_PZ_GW04	10/08/2020	9200
Electrical Conductivity	µS/cm	DG_A_I_PZ_GW04	7/09/2020	10023
Electrical Conductivity	µS/cm	DG_A_I_PZ_GW04	15/10/2020	9600
Electrical Conductivity	µS/cm	DG_A_I_PZ_GW04	25/11/2020	10037
Electrical Conductivity	µS/cm	DG_A_I_PZ_GW04	9/12/2020	9756
Electrical Conductivity	µS/cm	DG_A_I_PZ_GW05	9/07/2020	9000
Electrical Conductivity	µS/cm	DG_A_I_PZ_GW05	17/08/2020	8900
Electrical Conductivity	µS/cm	DG_A_I_PZ_GW05	7/09/2020	9557
Electrical Conductivity	µS/cm	DG_A_I_PZ_GW05	19/10/2020	8917
Electrical Conductivity	µS/cm	DG_A_I_PZ_GW05	25/11/2020	9663
Electrical Conductivity	µS/cm	DG_A_I_PZ_GW05	4/12/2020	9439
Electrical Conductivity	µS/cm	DG_A_I_PZ_GW08	6/07/2020	20000
Electrical Conductivity	µS/cm	DG_A_I_PZ_GW08	25/08/2020	21616
Electrical Conductivity	µS/cm	DG_A_I_PZ_GW08	8/09/2020	21795
Electrical Conductivity	µS/cm	DG_A_I_PZ_GW08	19/10/2020	20280
Electrical Conductivity	µS/cm	DG_A_I_PZ_GW08	26/11/2020	21486
Electrical Conductivity	µS/cm	DG_A_I_PZ_GW08	10/12/2020	21180
Electrical Conductivity	µS/cm	DG_A_I_PZ_BW36A	7/07/2020	6900
Electrical Conductivity	µS/cm	DG_A_I_PZ_BW36A	17/08/2020	7000
Electrical Conductivity	µS/cm	DG_A_I_PZ_BW36A	7/09/2020	7812
Electrical Conductivity	µS/cm	DG_A_I_PZ_BW36A	19/10/2020	7550
Electrical Conductivity	µS/cm	DG_A_I_PZ_BW36A	25/11/2020	8359
Electrical Conductivity	µS/cm	DG_A_I_PZ_BW36A	9/12/2020	8250
Electrical Conductivity	µS/cm	DG_A_I_PZ_GW04A	30/11/2020	8100
Electrical Conductivity	µS/cm	DG_A_I_PZ_GW04A	10/12/2020	8279
pH	pH units	DG_A_I_PZ_BW28A	8/07/2020	6.55
pH	pH units	DG_A_I_PZ_BW28A	10/08/2020	6.58
pH	pH units	DG_A_I_PZ_BW53/Puls	9/07/2020	6.86
pH	pH units	DG_A_I_PZ_BW53/Puls	17/08/2020	6.42
pH	pH units	DG_A_I_PZ_BW05	8/07/2020	7
pH	pH units	DG_A_I_PZ_IWB2	8/07/2020	5.43
pH	pH units	DG_A_I_PZ_IWB6	8/07/2020	5.19
pH	pH units	DG_A_I_PZ_WRK300	13/07/2020	6.75
pH	pH units	DG_A_I_PZ_WRK300	20/08/2020	6.65

Variable	Unit	Sample Point	Date	Result
pH	pH units	DG_A_I_PZ_WRK300	8/09/2020	6.65
pH	pH units	DG_A_I_PZ_WRK300	19/10/2020	6.53
pH	pH units	DG_A_I_PZ_WRK300	25/11/2020	6.53
pH	pH units	DG_A_I_PZ_WRK300	14/12/2020	6.28
pH	pH units	DG_A_I_PZ_WRK301	13/07/2020	7.04
pH	pH units	DG_A_I_PZ_WRK301	25/08/2020	7
pH	pH units	DG_A_I_PZ_WRK301	9/09/2020	7.03
pH	pH units	DG_A_I_PZ_WRK301	20/10/2020	7.04
pH	pH units	DG_A_I_PZ_WRK301	30/11/2020	6.82
pH	pH units	DG_A_I_PZ_WRK301	14/12/2020	6.84
pH	pH units	DG_A_I_PZ_WRK302	6/07/2020	5.98
pH	pH units	DG_A_I_PZ_WRK302	25/08/2020	5.92
pH	pH units	DG_A_I_PZ_WRK302	3/09/2020	5.93
pH	pH units	DG_A_I_PZ_WRK302	19/10/2020	5.96
pH	pH units	DG_A_I_PZ_WRK302	26/11/2020	5.88
pH	pH units	DG_A_I_PZ_WRK302	10/12/2020	5.98
pH	pH units	DG_A_I_PZ_WRK303	13/07/2020	6.04
pH	pH units	DG_A_I_PZ_WRK303	19/08/2020	5.83
pH	pH units	DG_A_I_PZ_WRK303	9/09/2020	6.07
pH	pH units	DG_A_I_PZ_WRK303	20/10/2020	5.92
pH	pH units	DG_A_I_PZ_WRK303	30/11/2020	5.9
pH	pH units	DG_A_I_PZ_WRK303	14/12/2020	5.76
pH	pH units	DG_A_I_PZ_WRK304	14/07/2020	6.11
pH	pH units	DG_A_I_PZ_WRK304	19/08/2020	6.06
pH	pH units	DG_A_I_PZ_WRK304	9/09/2020	6.17
pH	pH units	DG_A_I_PZ_WRK304	20/10/2020	6.14
pH	pH units	DG_A_I_PZ_WRK304	30/11/2020	6.02
pH	pH units	DG_A_I_PZ_WRK304	14/12/2020	5.91
pH	pH units	DG_A_I_PZ_GW01	7/07/2020	5.35
pH	pH units	DG_A_I_PZ_GW01	10/08/2020	5.55
pH	pH units	DG_A_I_PZ_GW01	7/09/2020	5.38
pH	pH units	DG_A_I_PZ_GW01	16/10/2020	5.48
pH	pH units	DG_A_I_PZ_GW01	24/11/2020	5.32
pH	pH units	DG_A_I_PZ_GW01	9/12/2020	5.26
pH	pH units	DG_A_I_PZ_GW06	6/07/2020	6.56
pH	pH units	DG_A_I_PZ_GW06	25/08/2020	6.53
pH	pH units	DG_A_I_PZ_GW06	8/09/2020	6.56
pH	pH units	DG_A_I_PZ_GW06	19/10/2020	6.55
pH	pH units	DG_A_I_PZ_GW06	26/11/2020	6.45
pH	pH units	DG_A_I_PZ_GW06	10/12/2020	6.59
pH	pH units	DG_A_I_PZ_GW07	2/07/2020	6.37
pH	pH units	DG_A_I_PZ_GW07	20/08/2020	6.27
pH	pH units	DG_A_I_PZ_GW07	7/09/2020	6.36
pH	pH units	DG_A_I_PZ_GW07	16/10/2020	6.37

Variable	Unit	Sample Point	Date	Result
pH	pH units	DG_A_I_PZ_GW07	24/11/2020	6.31
pH	pH units	DG_A_I_PZ_GW07	8/12/2020	6.31
pH	pH units	DG_A_I_PZ_BW45B	7/07/2020	4.43
pH	pH units	DG_A_I_PZ_BW45B	19/08/2020	4.77
pH	pH units	DG_A_I_PZ_BW45B	7/09/2020	4.49
pH	pH units	DG_A_I_PZ_BW45B	16/10/2020	4.4
pH	pH units	DG_A_I_PZ_BW45B	24/11/2020	4.24
pH	pH units	DG_A_I_PZ_BW45B	9/12/2020	4.3
pH	pH units	DG_A_I_PZ_GW02	2/07/2020	5.46
pH	pH units	DG_A_I_PZ_GW02	10/08/2020	5.51
pH	pH units	DG_A_I_PZ_GW02	3/09/2020	5.47
pH	pH units	DG_A_I_PZ_GW02	15/10/2020	5.54
pH	pH units	DG_A_I_PZ_GW02	24/11/2020	5.42
pH	pH units	DG_A_I_PZ_GW02	8/12/2020	5.37
pH	pH units	DG_A_I_PZ_GW03	2/07/2020	6.13
pH	pH units	DG_A_I_PZ_GW03	20/08/2020	6.12
pH	pH units	DG_A_I_PZ_GW03	3/09/2020	6.11
pH	pH units	DG_A_I_PZ_GW03	15/10/2020	6.23
pH	pH units	DG_A_I_PZ_GW03	24/11/2020	6.06
pH	pH units	DG_A_I_PZ_GW03	8/12/2020	6.05
pH	pH units	DG_A_I_PZ_GW04	9/07/2020	5.66
pH	pH units	DG_A_I_PZ_GW04	10/08/2020	5.67
pH	pH units	DG_A_I_PZ_GW04	7/09/2020	5.69
pH	pH units	DG_A_I_PZ_GW04	15/10/2020	5.72
pH	pH units	DG_A_I_PZ_GW04	25/11/2020	5.52
pH	pH units	DG_A_I_PZ_GW04	9/12/2020	5.53
pH	pH units	DG_A_I_PZ_GW05	9/07/2020	6
pH	pH units	DG_A_I_PZ_GW05	17/08/2020	6.03
pH	pH units	DG_A_I_PZ_GW05	7/09/2020	5.96
pH	pH units	DG_A_I_PZ_GW05	19/10/2020	5.94
pH	pH units	DG_A_I_PZ_GW05	25/11/2020	5.86
pH	pH units	DG_A_I_PZ_GW05	4/12/2020	5.87
pH	pH units	DG_A_I_PZ_GW08	6/07/2020	6.27
pH	pH units	DG_A_I_PZ_GW08	25/08/2020	6.23
pH	pH units	DG_A_I_PZ_GW08	8/09/2020	6.25
pH	pH units	DG_A_I_PZ_GW08	19/10/2020	6.26
pH	pH units	DG_A_I_PZ_GW08	26/11/2020	6.17
pH	pH units	DG_A_I_PZ_GW08	10/12/2020	6.25
pH	pH units	DG_A_I_PZ_BW36A	7/07/2020	6.78
pH	pH units	DG_A_I_PZ_BW36A	17/08/2020	6.77
pH	pH units	DG_A_I_PZ_BW36A	7/09/2020	6.65
pH	pH units	DG_A_I_PZ_BW36A	19/10/2020	6.67
pH	pH units	DG_A_I_PZ_BW36A	25/11/2020	6.5
pH	pH units	DG_A_I_PZ_BW36A	9/12/2020	6.55

Variable	Unit	Sample Point	Date	Result
pH	pH units	DG_A_I_PZ_GW04A	30/11/2020	6.42
pH	pH units	DG_A_I_PZ_GW04A	10/12/2020	6.17
Redox Potential (Eh)	mV	DG_A_I_PZ_BW28A	8/07/2020	-16
Redox Potential (Eh)	mV	DG_A_I_PZ_BW28A	10/08/2020	-10
Redox Potential (Eh)	mV	DG_A_I_PZ_BW53/Puls	9/07/2020	-130
Redox Potential (Eh)	mV	DG_A_I_PZ_BW53/Puls	17/08/2020	-6
Redox Potential (Eh)	mV	DG_A_I_PZ_BW05	8/07/2020	-10
Redox Potential (Eh)	mV	DG_A_I_PZ_IWB2	8/07/2020	315
Redox Potential (Eh)	mV	DG_A_I_PZ_IWB6	8/07/2020	346
Redox Potential (Eh)	mV	DG_A_I_PZ_WRK300	13/07/2020	138
Redox Potential (Eh)	mV	DG_A_I_PZ_WRK300	20/08/2020	139
Redox Potential (Eh)	mV	DG_A_I_PZ_WRK300	8/09/2020	229
Redox Potential (Eh)	mV	DG_A_I_PZ_WRK300	19/10/2020	162
Redox Potential (Eh)	mV	DG_A_I_PZ_WRK300	25/11/2020	101
Redox Potential (Eh)	mV	DG_A_I_PZ_WRK300	14/12/2020	88
Redox Potential (Eh)	mV	DG_A_I_PZ_WRK301	13/07/2020	147
Redox Potential (Eh)	mV	DG_A_I_PZ_WRK301	25/08/2020	86
Redox Potential (Eh)	mV	DG_A_I_PZ_WRK301	9/09/2020	261
Redox Potential (Eh)	mV	DG_A_I_PZ_WRK301	20/10/2020	90
Redox Potential (Eh)	mV	DG_A_I_PZ_WRK301	30/11/2020	91
Redox Potential (Eh)	mV	DG_A_I_PZ_WRK301	14/12/2020	76
Redox Potential (Eh)	mV	DG_A_I_PZ_WRK302	6/07/2020	182
Redox Potential (Eh)	mV	DG_A_I_PZ_WRK302	25/08/2020	185
Redox Potential (Eh)	mV	DG_A_I_PZ_WRK302	3/09/2020	235
Redox Potential (Eh)	mV	DG_A_I_PZ_WRK302	19/10/2020	240
Redox Potential (Eh)	mV	DG_A_I_PZ_WRK302	26/11/2020	236
Redox Potential (Eh)	mV	DG_A_I_PZ_WRK302	10/12/2020	191
Redox Potential (Eh)	mV	DG_A_I_PZ_WRK303	13/07/2020	209
Redox Potential (Eh)	mV	DG_A_I_PZ_WRK303	19/08/2020	244
Redox Potential (Eh)	mV	DG_A_I_PZ_WRK303	9/09/2020	200
Redox Potential (Eh)	mV	DG_A_I_PZ_WRK303	20/10/2020	210
Redox Potential (Eh)	mV	DG_A_I_PZ_WRK303	30/11/2020	220
Redox Potential (Eh)	mV	DG_A_I_PZ_WRK303	14/12/2020	169
Redox Potential (Eh)	mV	DG_A_I_PZ_WRK304	14/07/2020	221
Redox Potential (Eh)	mV	DG_A_I_PZ_WRK304	19/08/2020	215
Redox Potential (Eh)	mV	DG_A_I_PZ_WRK304	9/09/2020	547
Redox Potential (Eh)	mV	DG_A_I_PZ_WRK304	20/10/2020	212
Redox Potential (Eh)	mV	DG_A_I_PZ_WRK304	30/11/2020	200
Redox Potential (Eh)	mV	DG_A_I_PZ_WRK304	14/12/2020	186
Redox Potential (Eh)	mV	DG_A_I_PZ_GW01	7/07/2020	228
Redox Potential (Eh)	mV	DG_A_I_PZ_GW01	10/08/2020	489
Redox Potential (Eh)	mV	DG_A_I_PZ_GW01	7/09/2020	172
Redox Potential (Eh)	mV	DG_A_I_PZ_GW01	16/10/2020	261
Redox Potential (Eh)	mV	DG_A_I_PZ_GW01	24/11/2020	199

Variable	Unit	Sample Point	Date	Result
Redox Potential (Eh)	mV	DG_A_I_PZ_GW01	9/12/2020	216
Redox Potential (Eh)	mV	DG_A_I_PZ_GW06	6/07/2020	164
Redox Potential (Eh)	mV	DG_A_I_PZ_GW06	25/08/2020	165
Redox Potential (Eh)	mV	DG_A_I_PZ_GW06	8/09/2020	252
Redox Potential (Eh)	mV	DG_A_I_PZ_GW06	19/10/2020	218
Redox Potential (Eh)	mV	DG_A_I_PZ_GW06	26/11/2020	284
Redox Potential (Eh)	mV	DG_A_I_PZ_GW06	10/12/2020	184
Redox Potential (Eh)	mV	DG_A_I_PZ_GW07	2/07/2020	210
Redox Potential (Eh)	mV	DG_A_I_PZ_GW07	20/08/2020	222
Redox Potential (Eh)	mV	DG_A_I_PZ_GW07	7/09/2020	252
Redox Potential (Eh)	mV	DG_A_I_PZ_GW07	16/10/2020	210
Redox Potential (Eh)	mV	DG_A_I_PZ_GW07	24/11/2020	155
Redox Potential (Eh)	mV	DG_A_I_PZ_GW07	8/12/2020	191
Redox Potential (Eh)	mV	DG_A_I_PZ_BW45B	7/07/2020	283
Redox Potential (Eh)	mV	DG_A_I_PZ_BW45B	19/08/2020	273
Redox Potential (Eh)	mV	DG_A_I_PZ_BW45B	7/09/2020	234
Redox Potential (Eh)	mV	DG_A_I_PZ_BW45B	16/10/2020	310
Redox Potential (Eh)	mV	DG_A_I_PZ_BW45B	24/11/2020	286
Redox Potential (Eh)	mV	DG_A_I_PZ_BW45B	9/12/2020	240
Redox Potential (Eh)	mV	DG_A_I_PZ_GW02	2/07/2020	234
Redox Potential (Eh)	mV	DG_A_I_PZ_GW02	10/08/2020	309
Redox Potential (Eh)	mV	DG_A_I_PZ_GW02	3/09/2020	315
Redox Potential (Eh)	mV	DG_A_I_PZ_GW02	15/10/2020	286
Redox Potential (Eh)	mV	DG_A_I_PZ_GW02	24/11/2020	177
Redox Potential (Eh)	mV	DG_A_I_PZ_GW02	8/12/2020	135
Redox Potential (Eh)	mV	DG_A_I_PZ_GW03	2/07/2020	35
Redox Potential (Eh)	mV	DG_A_I_PZ_GW03	20/08/2020	71
Redox Potential (Eh)	mV	DG_A_I_PZ_GW03	3/09/2020	115
Redox Potential (Eh)	mV	DG_A_I_PZ_GW03	15/10/2020	88
Redox Potential (Eh)	mV	DG_A_I_PZ_GW03	24/11/2020	63
Redox Potential (Eh)	mV	DG_A_I_PZ_GW03	8/12/2020	107
Redox Potential (Eh)	mV	DG_A_I_PZ_GW04	9/07/2020	156
Redox Potential (Eh)	mV	DG_A_I_PZ_GW04	10/08/2020	380
Redox Potential (Eh)	mV	DG_A_I_PZ_GW04	7/09/2020	340
Redox Potential (Eh)	mV	DG_A_I_PZ_GW04	15/10/2020	279
Redox Potential (Eh)	mV	DG_A_I_PZ_GW04	25/11/2020	293
Redox Potential (Eh)	mV	DG_A_I_PZ_GW04	9/12/2020	202
Redox Potential (Eh)	mV	DG_A_I_PZ_GW05	9/07/2020	134
Redox Potential (Eh)	mV	DG_A_I_PZ_GW05	17/08/2020	384
Redox Potential (Eh)	mV	DG_A_I_PZ_GW05	7/09/2020	302
Redox Potential (Eh)	mV	DG_A_I_PZ_GW05	19/10/2020	222
Redox Potential (Eh)	mV	DG_A_I_PZ_GW05	25/11/2020	260
Redox Potential (Eh)	mV	DG_A_I_PZ_GW05	4/12/2020	190
Redox Potential (Eh)	mV	DG_A_I_PZ_GW08	6/07/2020	173

Variable	Unit	Sample Point	Date	Result
Redox Potential (Eh)	mV	DG_A_I_PZ_GW08	25/08/2020	191
Redox Potential (Eh)	mV	DG_A_I_PZ_GW08	8/09/2020	235
Redox Potential (Eh)	mV	DG_A_I_PZ_GW08	19/10/2020	215
Redox Potential (Eh)	mV	DG_A_I_PZ_GW08	26/11/2020	203
Redox Potential (Eh)	mV	DG_A_I_PZ_GW08	10/12/2020	185
Redox Potential (Eh)	mV	DG_A_I_PZ_BW36A	7/07/2020	-41
Redox Potential (Eh)	mV	DG_A_I_PZ_BW36A	17/08/2020	9
Redox Potential (Eh)	mV	DG_A_I_PZ_BW36A	7/09/2020	-72
Redox Potential (Eh)	mV	DG_A_I_PZ_BW36A	19/10/2020	-66
Redox Potential (Eh)	mV	DG_A_I_PZ_BW36A	25/11/2020	-100
Redox Potential (Eh)	mV	DG_A_I_PZ_BW36A	9/12/2020	-54
Redox Potential (Eh)	mV	DG_A_I_PZ_GW04A	30/11/2020	647
Redox Potential (Eh)	mV	DG_A_I_PZ_GW04A	10/12/2020	160
Standing Water Level	mAHD	DG_A_I_PZ_BW28A	8/07/2020	152.5
Standing Water Level	mAHD	DG_A_I_PZ_BW28A	10/08/2020	152.48
Standing Water Level	mAHD	DG_A_I_PZ_BW53/Puls	9/07/2020	175.81
Standing Water Level	mAHD	DG_A_I_PZ_BW53/Puls	17/08/2020	176.29
Standing Water Level	mAHD	DG_A_I_PZ_BW53/Puls	8/09/2020	176.23
Standing Water Level	mAHD	DG_A_I_PZ_BW53/Puls	12/10/2020	176.26
Standing Water Level	mAHD	DG_A_I_PZ_BW53/Puls	24/11/2020	176.18
Standing Water Level	mAHD	DG_A_I_PZ_BW53/Puls	10/12/2020	176.25
Standing Water Level	mAHD	DG_A_I_PZ_BW05	8/07/2020	147.439
Standing Water Level	mAHD	DG_A_I_PZ_IWB2	8/07/2020	179.656
Standing Water Level	mAHD	DG_A_I_PZ_IWB2	20/08/2020	179.876
Standing Water Level	mAHD	DG_A_I_PZ_IWB2	8/09/2020	179.716
Standing Water Level	mAHD	DG_A_I_PZ_IWB2	12/10/2020	179.716
Standing Water Level	mAHD	DG_A_I_PZ_IWB2	24/11/2020	179.756
Standing Water Level	mAHD	DG_A_I_PZ_IWB2	10/12/2020	179.696
Standing Water Level	mAHD	DG_A_I_PZ_IWB6	8/07/2020	176.85
Standing Water Level	mAHD	DG_A_I_PZ_IWB6	20/08/2020	177
Standing Water Level	mAHD	DG_A_I_PZ_IWB6	8/09/2020	176.68
Standing Water Level	mAHD	DG_A_I_PZ_IWB6	12/10/2020	176.76
Standing Water Level	mAHD	DG_A_I_PZ_IWB6	24/11/2020	176.38
Standing Water Level	mAHD	DG_A_I_PZ_IWB6	10/12/2020	176.54
Standing Water Level	mAHD	DG_A_I_PZ_WRK300	13/07/2020	175.11
Standing Water Level	mAHD	DG_A_I_PZ_WRK300	20/08/2020	175.07
Standing Water Level	mAHD	DG_A_I_PZ_WRK300	8/09/2020	175.14
Standing Water Level	mAHD	DG_A_I_PZ_WRK300	19/10/2020	175.21
Standing Water Level	mAHD	DG_A_I_PZ_WRK300	25/11/2020	175.16
Standing Water Level	mAHD	DG_A_I_PZ_WRK300	14/12/2020	175.18
Standing Water Level	mAHD	DG_A_I_PZ_WRK301	13/07/2020	178.18
Standing Water Level	mAHD	DG_A_I_PZ_WRK301	25/08/2020	178.19
Standing Water Level	mAHD	DG_A_I_PZ_WRK301	9/09/2020	178.23
Standing Water Level	mAHD	DG_A_I_PZ_WRK301	20/10/2020	178.24

Variable	Unit	Sample Point	Date	Result
Standing Water Level	mAHD	DG_A_I_PZ_WRK301	30/11/2020	178.18
Standing Water Level	mAHD	DG_A_I_PZ_WRK301	14/12/2020	178.21
Standing Water Level	mAHD	DG_A_I_PZ_WRK302	6/07/2020	176.77
Standing Water Level	mAHD	DG_A_I_PZ_WRK302	25/08/2020	176.71
Standing Water Level	mAHD	DG_A_I_PZ_WRK302	3/09/2020	176.75
Standing Water Level	mAHD	DG_A_I_PZ_WRK302	19/10/2020	176.69
Standing Water Level	mAHD	DG_A_I_PZ_WRK302	26/11/2020	176.77
Standing Water Level	mAHD	DG_A_I_PZ_WRK302	10/12/2020	176.75
Standing Water Level	mAHD	DG_A_I_PZ_WRK303	13/07/2020	179.84
Standing Water Level	mAHD	DG_A_I_PZ_WRK303	19/08/2020	179.89
Standing Water Level	mAHD	DG_A_I_PZ_WRK303	9/09/2020	179.85
Standing Water Level	mAHD	DG_A_I_PZ_WRK303	20/10/2020	179.9
Standing Water Level	mAHD	DG_A_I_PZ_WRK303	30/11/2020	179.88
Standing Water Level	mAHD	DG_A_I_PZ_WRK303	14/12/2020	179.85
Standing Water Level	mAHD	DG_A_I_PZ_WRK304	14/07/2020	180.44
Standing Water Level	mAHD	DG_A_I_PZ_WRK304	19/08/2020	180.49
Standing Water Level	mAHD	DG_A_I_PZ_WRK304	9/09/2020	180.46
Standing Water Level	mAHD	DG_A_I_PZ_WRK304	20/10/2020	180.39
Standing Water Level	mAHD	DG_A_I_PZ_WRK304	30/11/2020	180.37
Standing Water Level	mAHD	DG_A_I_PZ_WRK304	14/12/2020	180.41
Standing Water Level	mAHD	DG_A_I_PZ_GW01	7/07/2020	173.475
Standing Water Level	mAHD	DG_A_I_PZ_GW01	10/08/2020	173.515
Standing Water Level	mAHD	DG_A_I_PZ_GW01	7/09/2020	173.425
Standing Water Level	mAHD	DG_A_I_PZ_GW01	16/10/2020	173.415
Standing Water Level	mAHD	DG_A_I_PZ_GW01	24/11/2020	173.435
Standing Water Level	mAHD	DG_A_I_PZ_GW01	9/12/2020	173.515
Standing Water Level	mAHD	DG_A_I_PZ_GW06	6/07/2020	176.224
Standing Water Level	mAHD	DG_A_I_PZ_GW06	25/08/2020	176.184
Standing Water Level	mAHD	DG_A_I_PZ_GW06	8/09/2020	176.114
Standing Water Level	mAHD	DG_A_I_PZ_GW06	19/10/2020	176.174
Standing Water Level	mAHD	DG_A_I_PZ_GW06	26/11/2020	176.214
Standing Water Level	mAHD	DG_A_I_PZ_GW06	10/12/2020	176.204
Standing Water Level	mAHD	DG_A_I_PZ_GW07	2/07/2020	172.536
Standing Water Level	mAHD	DG_A_I_PZ_GW07	20/08/2020	172.476
Standing Water Level	mAHD	DG_A_I_PZ_GW07	7/09/2020	172.516
Standing Water Level	mAHD	DG_A_I_PZ_GW07	16/10/2020	172.536
Standing Water Level	mAHD	DG_A_I_PZ_GW07	24/11/2020	172.466
Standing Water Level	mAHD	DG_A_I_PZ_GW07	8/12/2020	172.536
Standing Water Level	mAHD	DG_A_I_PZ_BW45B	7/07/2020	177.37
Standing Water Level	mAHD	DG_A_I_PZ_BW45B	19/08/2020	177.35
Standing Water Level	mAHD	DG_A_I_PZ_BW45B	7/09/2020	177.38
Standing Water Level	mAHD	DG_A_I_PZ_BW45B	16/10/2020	177.34
Standing Water Level	mAHD	DG_A_I_PZ_BW45B	24/11/2020	177.36
Standing Water Level	mAHD	DG_A_I_PZ_BW45B	9/12/2020	177.4

Variable	Unit	Sample Point	Date	Result
Standing Water Level	mAHD	DG_A_I_PZ_GW02	2/07/2020	170.77
Standing Water Level	mAHD	DG_A_I_PZ_GW02	10/08/2020	170.78
Standing Water Level	mAHD	DG_A_I_PZ_GW02	3/09/2020	170.72
Standing Water Level	mAHD	DG_A_I_PZ_GW02	15/10/2020	170.86
Standing Water Level	mAHD	DG_A_I_PZ_GW02	24/11/2020	170.79
Standing Water Level	mAHD	DG_A_I_PZ_GW02	8/12/2020	170.8
Standing Water Level	mAHD	DG_A_I_PZ_GW03	2/07/2020	162.02
Standing Water Level	mAHD	DG_A_I_PZ_GW03	20/08/2020	162.05
Standing Water Level	mAHD	DG_A_I_PZ_GW03	3/09/2020	162.01
Standing Water Level	mAHD	DG_A_I_PZ_GW03	15/10/2020	162.06
Standing Water Level	mAHD	DG_A_I_PZ_GW03	24/11/2020	162.01
Standing Water Level	mAHD	DG_A_I_PZ_GW03	8/12/2020	162.04
Standing Water Level	mAHD	DG_A_I_PZ_GW04	9/07/2020	178.13
Standing Water Level	mAHD	DG_A_I_PZ_GW04	10/08/2020	178.17
Standing Water Level	mAHD	DG_A_I_PZ_GW04	7/09/2020	178.13
Standing Water Level	mAHD	DG_A_I_PZ_GW04	15/10/2020	178.2
Standing Water Level	mAHD	DG_A_I_PZ_GW04	25/11/2020	178.29
Standing Water Level	mAHD	DG_A_I_PZ_GW04	9/12/2020	178.27
Standing Water Level	mAHD	DG_A_I_PZ_GW05	9/07/2020	178.89
Standing Water Level	mAHD	DG_A_I_PZ_GW05	17/08/2020	178.94
Standing Water Level	mAHD	DG_A_I_PZ_GW05	7/09/2020	178.88
Standing Water Level	mAHD	DG_A_I_PZ_GW05	19/10/2020	178.94
Standing Water Level	mAHD	DG_A_I_PZ_GW05	25/11/2020	179
Standing Water Level	mAHD	DG_A_I_PZ_GW05	4/12/2020	178.97
Standing Water Level	mAHD	DG_A_I_PZ_GW08	6/07/2020	177.53
Standing Water Level	mAHD	DG_A_I_PZ_GW08	25/08/2020	177.59
Standing Water Level	mAHD	DG_A_I_PZ_GW08	8/09/2020	177.41
Standing Water Level	mAHD	DG_A_I_PZ_GW08	19/10/2020	177.56
Standing Water Level	mAHD	DG_A_I_PZ_GW08	26/11/2020	177.48
Standing Water Level	mAHD	DG_A_I_PZ_GW08	10/12/2020	177.45
Standing Water Level	mAHD	DG_A_I_PZ_BW36A	7/07/2020	174.475
Standing Water Level	mAHD	DG_A_I_PZ_BW36A	17/08/2020	174.425
Standing Water Level	mAHD	DG_A_I_PZ_BW36A	7/09/2020	174.635
Standing Water Level	mAHD	DG_A_I_PZ_BW36A	19/10/2020	174.385
Standing Water Level	mAHD	DG_A_I_PZ_BW36A	25/11/2020	174.465
Standing Water Level	mAHD	DG_A_I_PZ_BW36A	9/12/2020	174.465
Standing Water Level	mAHD	DG_A_I_PZ_GW04A	10/12/2020	-24.48
Standing Water Level (mBTOC)	m	DG_A_I_PZ_BW28A	8/07/2020	4.19
Standing Water Level (mBTOC)	m	DG_A_I_PZ_BW28A	10/08/2020	4.21
Standing Water Level (mBTOC)	m	DG_A_I_PZ_BW53/Puls	9/07/2020	10.32
Standing Water Level (mBTOC)	m	DG_A_I_PZ_BW53/Puls	17/08/2020	9.84
Standing Water Level (mBTOC)	m	DG_A_I_PZ_BW53/Puls	8/09/2020	9.9
Standing Water Level (mBTOC)	m	DG_A_I_PZ_BW53/Puls	12/10/2020	9.87
Standing Water Level (mBTOC)	m	DG_A_I_PZ_BW53/Puls	24/11/2020	9.95

Variable	Unit	Sample Point	Date	Result
Standing Water Level (mBTOC)	m	DG_A_I_PZ_BW53/Puls	10/12/2020	9.88
Standing Water Level (mBTOC)	m	DG_A_I_PZ_BW05	8/07/2020	5.33
Standing Water Level (mBTOC)	m	DG_A_I_PZ_IWB2	8/07/2020	12.26
Standing Water Level (mBTOC)	m	DG_A_I_PZ_IWB2	20/08/2020	12.04
Standing Water Level (mBTOC)	m	DG_A_I_PZ_IWB2	8/09/2020	12.2
Standing Water Level (mBTOC)	m	DG_A_I_PZ_IWB2	12/10/2020	12.2
Standing Water Level (mBTOC)	m	DG_A_I_PZ_IWB2	24/11/2020	12.16
Standing Water Level (mBTOC)	m	DG_A_I_PZ_IWB2	10/12/2020	12.22
Standing Water Level (mBTOC)	m	DG_A_I_PZ_IWB6	8/07/2020	1.85
Standing Water Level (mBTOC)	m	DG_A_I_PZ_IWB6	20/08/2020	1.7
Standing Water Level (mBTOC)	m	DG_A_I_PZ_IWB6	8/09/2020	2.02
Standing Water Level (mBTOC)	m	DG_A_I_PZ_IWB6	12/10/2020	1.94
Standing Water Level (mBTOC)	m	DG_A_I_PZ_IWB6	24/11/2020	2.32
Standing Water Level (mBTOC)	m	DG_A_I_PZ_IWB6	10/12/2020	2.16
Standing Water Level (mBTOC)	m	DG_A_I_PZ_WRK300	13/07/2020	24.51
Standing Water Level (mBTOC)	m	DG_A_I_PZ_WRK300	20/08/2020	24.55
Standing Water Level (mBTOC)	m	DG_A_I_PZ_WRK300	8/09/2020	24.48
Standing Water Level (mBTOC)	m	DG_A_I_PZ_WRK300	19/10/2020	24.41
Standing Water Level (mBTOC)	m	DG_A_I_PZ_WRK300	25/11/2020	24.46
Standing Water Level (mBTOC)	m	DG_A_I_PZ_WRK300	14/12/2020	24.44
Standing Water Level (mBTOC)	m	DG_A_I_PZ_WRK301	13/07/2020	18.6
Standing Water Level (mBTOC)	m	DG_A_I_PZ_WRK301	25/08/2020	18.59
Standing Water Level (mBTOC)	m	DG_A_I_PZ_WRK301	9/09/2020	18.55
Standing Water Level (mBTOC)	m	DG_A_I_PZ_WRK301	20/10/2020	18.54
Standing Water Level (mBTOC)	m	DG_A_I_PZ_WRK301	30/11/2020	18.6
Standing Water Level (mBTOC)	m	DG_A_I_PZ_WRK301	14/12/2020	18.57
Standing Water Level (mBTOC)	m	DG_A_I_PZ_WRK302	6/07/2020	13.51
Standing Water Level (mBTOC)	m	DG_A_I_PZ_WRK302	25/08/2020	13.57
Standing Water Level (mBTOC)	m	DG_A_I_PZ_WRK302	3/09/2020	13.53
Standing Water Level (mBTOC)	m	DG_A_I_PZ_WRK302	19/10/2020	13.59
Standing Water Level (mBTOC)	m	DG_A_I_PZ_WRK302	26/11/2020	13.51
Standing Water Level (mBTOC)	m	DG_A_I_PZ_WRK302	10/12/2020	13.53
Standing Water Level (mBTOC)	m	DG_A_I_PZ_WRK303	13/07/2020	20.56
Standing Water Level (mBTOC)	m	DG_A_I_PZ_WRK303	19/08/2020	20.51
Standing Water Level (mBTOC)	m	DG_A_I_PZ_WRK303	9/09/2020	20.55
Standing Water Level (mBTOC)	m	DG_A_I_PZ_WRK303	20/10/2020	20.5
Standing Water Level (mBTOC)	m	DG_A_I_PZ_WRK303	30/11/2020	20.52
Standing Water Level (mBTOC)	m	DG_A_I_PZ_WRK303	14/12/2020	20.55
Standing Water Level (mBTOC)	m	DG_A_I_PZ_WRK304	14/07/2020	18.63
Standing Water Level (mBTOC)	m	DG_A_I_PZ_WRK304	19/08/2020	18.58
Standing Water Level (mBTOC)	m	DG_A_I_PZ_WRK304	9/09/2020	18.61
Standing Water Level (mBTOC)	m	DG_A_I_PZ_WRK304	20/10/2020	18.68
Standing Water Level (mBTOC)	m	DG_A_I_PZ_WRK304	30/11/2020	18.7
Standing Water Level (mBTOC)	m	DG_A_I_PZ_WRK304	14/12/2020	18.66

Variable	Unit	Sample Point	Date	Result
Standing Water Level (mBTOC)	m	DG_A_I_PZ_GW01	7/07/2020	19.04
Standing Water Level (mBTOC)	m	DG_A_I_PZ_GW01	10/08/2020	19
Standing Water Level (mBTOC)	m	DG_A_I_PZ_GW01	7/09/2020	19.09
Standing Water Level (mBTOC)	m	DG_A_I_PZ_GW01	16/10/2020	19.1
Standing Water Level (mBTOC)	m	DG_A_I_PZ_GW01	24/11/2020	19.08
Standing Water Level (mBTOC)	m	DG_A_I_PZ_GW01	9/12/2020	19
Standing Water Level (mBTOC)	m	DG_A_I_PZ_GW06	6/07/2020	13.29
Standing Water Level (mBTOC)	m	DG_A_I_PZ_GW06	25/08/2020	13.33
Standing Water Level (mBTOC)	m	DG_A_I_PZ_GW06	8/09/2020	13.4
Standing Water Level (mBTOC)	m	DG_A_I_PZ_GW06	19/10/2020	13.34
Standing Water Level (mBTOC)	m	DG_A_I_PZ_GW06	26/11/2020	13.3
Standing Water Level (mBTOC)	m	DG_A_I_PZ_GW06	10/12/2020	13.31
Standing Water Level (mBTOC)	m	DG_A_I_PZ_GW07	2/07/2020	16.31
Standing Water Level (mBTOC)	m	DG_A_I_PZ_GW07	20/08/2020	16.37
Standing Water Level (mBTOC)	m	DG_A_I_PZ_GW07	7/09/2020	16.33
Standing Water Level (mBTOC)	m	DG_A_I_PZ_GW07	16/10/2020	16.31
Standing Water Level (mBTOC)	m	DG_A_I_PZ_GW07	24/11/2020	16.38
Standing Water Level (mBTOC)	m	DG_A_I_PZ_GW07	8/12/2020	16.31
Standing Water Level (mBTOC)	m	DG_A_I_PZ_BW45B	7/07/2020	19.88
Standing Water Level (mBTOC)	m	DG_A_I_PZ_BW45B	19/08/2020	19.9
Standing Water Level (mBTOC)	m	DG_A_I_PZ_BW45B	7/09/2020	19.87
Standing Water Level (mBTOC)	m	DG_A_I_PZ_BW45B	16/10/2020	19.91
Standing Water Level (mBTOC)	m	DG_A_I_PZ_BW45B	24/11/2020	19.89
Standing Water Level (mBTOC)	m	DG_A_I_PZ_BW45B	9/12/2020	19.85
Standing Water Level (mBTOC)	m	DG_A_I_PZ_GW02	2/07/2020	15.61
Standing Water Level (mBTOC)	m	DG_A_I_PZ_GW02	10/08/2020	15.6
Standing Water Level (mBTOC)	m	DG_A_I_PZ_GW02	3/09/2020	15.66
Standing Water Level (mBTOC)	m	DG_A_I_PZ_GW02	15/10/2020	15.52
Standing Water Level (mBTOC)	m	DG_A_I_PZ_GW02	24/11/2020	15.59
Standing Water Level (mBTOC)	m	DG_A_I_PZ_GW02	8/12/2020	15.58
Standing Water Level (mBTOC)	m	DG_A_I_PZ_GW03	2/07/2020	10.4
Standing Water Level (mBTOC)	m	DG_A_I_PZ_GW03	20/08/2020	10.37
Standing Water Level (mBTOC)	m	DG_A_I_PZ_GW03	3/09/2020	10.41
Standing Water Level (mBTOC)	m	DG_A_I_PZ_GW03	15/10/2020	10.36
Standing Water Level (mBTOC)	m	DG_A_I_PZ_GW03	24/11/2020	10.41
Standing Water Level (mBTOC)	m	DG_A_I_PZ_GW03	8/12/2020	10.38
Standing Water Level (mBTOC)	m	DG_A_I_PZ_GW04	9/07/2020	24.11
Standing Water Level (mBTOC)	m	DG_A_I_PZ_GW04	10/08/2020	24.07
Standing Water Level (mBTOC)	m	DG_A_I_PZ_GW04	7/09/2020	24.11
Standing Water Level (mBTOC)	m	DG_A_I_PZ_GW04	15/10/2020	24.04
Standing Water Level (mBTOC)	m	DG_A_I_PZ_GW04	25/11/2020	23.95
Standing Water Level (mBTOC)	m	DG_A_I_PZ_GW04	9/12/2020	23.97
Standing Water Level (mBTOC)	m	DG_A_I_PZ_GW05	9/07/2020	21.41
Standing Water Level (mBTOC)	m	DG_A_I_PZ_GW05	17/08/2020	21.36

Variable	Unit	Sample Point	Date	Result
Standing Water Level (mBTOC)	m	DG_A_I_PZ_GW05	7/09/2020	21.42
Standing Water Level (mBTOC)	m	DG_A_I_PZ_GW05	19/10/2020	21.36
Standing Water Level (mBTOC)	m	DG_A_I_PZ_GW05	25/11/2020	21.3
Standing Water Level (mBTOC)	m	DG_A_I_PZ_GW05	4/12/2020	21.33
Standing Water Level (mBTOC)	m	DG_A_I_PZ_GW08	6/07/2020	13.44
Standing Water Level (mBTOC)	m	DG_A_I_PZ_GW08	25/08/2020	13.38
Standing Water Level (mBTOC)	m	DG_A_I_PZ_GW08	8/09/2020	13.56
Standing Water Level (mBTOC)	m	DG_A_I_PZ_GW08	19/10/2020	13.41
Standing Water Level (mBTOC)	m	DG_A_I_PZ_GW08	26/11/2020	13.49
Standing Water Level (mBTOC)	m	DG_A_I_PZ_GW08	10/12/2020	13.52
Standing Water Level (mBTOC)	m	DG_A_I_PZ_BW36A	7/07/2020	26.26
Standing Water Level (mBTOC)	m	DG_A_I_PZ_BW36A	17/08/2020	26.31
Standing Water Level (mBTOC)	m	DG_A_I_PZ_BW36A	7/09/2020	26.1
Standing Water Level (mBTOC)	m	DG_A_I_PZ_BW36A	19/10/2020	26.35
Standing Water Level (mBTOC)	m	DG_A_I_PZ_BW36A	25/11/2020	26.27
Standing Water Level (mBTOC)	m	DG_A_I_PZ_BW36A	9/12/2020	26.27
Standing Water Level (mBTOC)	m	DG_A_I_PZ_GW04A	30/11/2020	24.42
Standing Water Level (mBTOC)	m	DG_A_I_PZ_GW04A	10/12/2020	24.48
Temperature	°C	DG_A_I_PZ_BW28A	8/07/2020	17.5
Temperature	°C	DG_A_I_PZ_BW28A	10/08/2020	17.5
Temperature	°C	DG_A_I_PZ_BW53/Puls	9/07/2020	15.1
Temperature	°C	DG_A_I_PZ_BW53/Puls	17/08/2020	15.5
Temperature	°C	DG_A_I_PZ_BW05	8/07/2020	17.2
Temperature	°C	DG_A_I_PZ_IWB2	8/07/2020	17.7
Temperature	°C	DG_A_I_PZ_IWB6	8/07/2020	16.9
Temperature	°C	DG_A_I_PZ_WRK300	13/07/2020	14.1
Temperature	°C	DG_A_I_PZ_WRK300	20/08/2020	14
Temperature	°C	DG_A_I_PZ_WRK300	8/09/2020	16.1
Temperature	°C	DG_A_I_PZ_WRK300	19/10/2020	16.6
Temperature	°C	DG_A_I_PZ_WRK300	25/11/2020	23.9
Temperature	°C	DG_A_I_PZ_WRK300	14/12/2020	27.4
Temperature	°C	DG_A_I_PZ_WRK301	13/07/2020	17.4
Temperature	°C	DG_A_I_PZ_WRK301	25/08/2020	17.6
Temperature	°C	DG_A_I_PZ_WRK301	9/09/2020	17.3
Temperature	°C	DG_A_I_PZ_WRK301	20/10/2020	18.5
Temperature	°C	DG_A_I_PZ_WRK301	30/11/2020	22
Temperature	°C	DG_A_I_PZ_WRK301	14/12/2020	25.2
Temperature	°C	DG_A_I_PZ_WRK302	6/07/2020	17.2
Temperature	°C	DG_A_I_PZ_WRK302	25/08/2020	17.1
Temperature	°C	DG_A_I_PZ_WRK302	3/09/2020	17.2
Temperature	°C	DG_A_I_PZ_WRK302	19/10/2020	17.2
Temperature	°C	DG_A_I_PZ_WRK302	26/11/2020	17.3
Temperature	°C	DG_A_I_PZ_WRK302	10/12/2020	17.8
Temperature	°C	DG_A_I_PZ_WRK303	13/07/2020	17.5

Variable	Unit	Sample Point	Date	Result
Temperature	°C	DG_A_I_PZ_WRK303	19/08/2020	15
Temperature	°C	DG_A_I_PZ_WRK303	9/09/2020	17.1
Temperature	°C	DG_A_I_PZ_WRK303	20/10/2020	18.8
Temperature	°C	DG_A_I_PZ_WRK303	30/11/2020	18.3
Temperature	°C	DG_A_I_PZ_WRK303	14/12/2020	18.2
Temperature	°C	DG_A_I_PZ_WRK304	14/07/2020	17
Temperature	°C	DG_A_I_PZ_WRK304	19/08/2020	15.2
Temperature	°C	DG_A_I_PZ_WRK304	9/09/2020	17
Temperature	°C	DG_A_I_PZ_WRK304	20/10/2020	16.9
Temperature	°C	DG_A_I_PZ_WRK304	30/11/2020	17.8
Temperature	°C	DG_A_I_PZ_WRK304	14/12/2020	17.7
Temperature	°C	DG_A_I_PZ_GW01	7/07/2020	15.6
Temperature	°C	DG_A_I_PZ_GW01	10/08/2020	16.5
Temperature	°C	DG_A_I_PZ_GW01	7/09/2020	20
Temperature	°C	DG_A_I_PZ_GW01	16/10/2020	16.5
Temperature	°C	DG_A_I_PZ_GW01	24/11/2020	20.7
Temperature	°C	DG_A_I_PZ_GW01	9/12/2020	17
Temperature	°C	DG_A_I_PZ_GW06	6/07/2020	17.6
Temperature	°C	DG_A_I_PZ_GW06	25/08/2020	17.5
Temperature	°C	DG_A_I_PZ_GW06	8/09/2020	17.7
Temperature	°C	DG_A_I_PZ_GW06	19/10/2020	17.7
Temperature	°C	DG_A_I_PZ_GW06	26/11/2020	17.5
Temperature	°C	DG_A_I_PZ_GW06	10/12/2020	17.9
Temperature	°C	DG_A_I_PZ_GW07	2/07/2020	17.9
Temperature	°C	DG_A_I_PZ_GW07	20/08/2020	18.3
Temperature	°C	DG_A_I_PZ_GW07	7/09/2020	18.1
Temperature	°C	DG_A_I_PZ_GW07	16/10/2020	18.1
Temperature	°C	DG_A_I_PZ_GW07	24/11/2020	18.1
Temperature	°C	DG_A_I_PZ_GW07	8/12/2020	18
Temperature	°C	DG_A_I_PZ_BW45B	7/07/2020	14.9
Temperature	°C	DG_A_I_PZ_BW45B	19/08/2020	13.2
Temperature	°C	DG_A_I_PZ_BW45B	7/09/2020	20.5
Temperature	°C	DG_A_I_PZ_BW45B	16/10/2020	16.3
Temperature	°C	DG_A_I_PZ_BW45B	24/11/2020	21.4
Temperature	°C	DG_A_I_PZ_BW45B	9/12/2020	17
Temperature	°C	DG_A_I_PZ_GW02	2/07/2020	17.7
Temperature	°C	DG_A_I_PZ_GW02	10/08/2020	17.7
Temperature	°C	DG_A_I_PZ_GW02	3/09/2020	17.6
Temperature	°C	DG_A_I_PZ_GW02	15/10/2020	17.8
Temperature	°C	DG_A_I_PZ_GW02	24/11/2020	17.8
Temperature	°C	DG_A_I_PZ_GW02	8/12/2020	17.5
Temperature	°C	DG_A_I_PZ_GW03	2/07/2020	18
Temperature	°C	DG_A_I_PZ_GW03	20/08/2020	17.3
Temperature	°C	DG_A_I_PZ_GW03	3/09/2020	17.9

Variable	Unit	Sample Point	Date	Result
Temperature	°C	DG_A_I_PZ_GW03	15/10/2020	18.3
Temperature	°C	DG_A_I_PZ_GW03	24/11/2020	19.8
Temperature	°C	DG_A_I_PZ_GW03	8/12/2020	18.8
Temperature	°C	DG_A_I_PZ_GW04	9/07/2020	15.1
Temperature	°C	DG_A_I_PZ_GW04	10/08/2020	18
Temperature	°C	DG_A_I_PZ_GW04	7/09/2020	21
Temperature	°C	DG_A_I_PZ_GW04	15/10/2020	18
Temperature	°C	DG_A_I_PZ_GW04	25/11/2020	22.7
Temperature	°C	DG_A_I_PZ_GW04	9/12/2020	19.9
Temperature	°C	DG_A_I_PZ_GW05	9/07/2020	14.6
Temperature	°C	DG_A_I_PZ_GW05	17/08/2020	16.5
Temperature	°C	DG_A_I_PZ_GW05	7/09/2020	18.2
Temperature	°C	DG_A_I_PZ_GW05	19/10/2020	16.8
Temperature	°C	DG_A_I_PZ_GW05	25/11/2020	22.4
Temperature	°C	DG_A_I_PZ_GW05	4/12/2020	19.3
Temperature	°C	DG_A_I_PZ_GW08	6/07/2020	17.7
Temperature	°C	DG_A_I_PZ_GW08	25/08/2020	17.4
Temperature	°C	DG_A_I_PZ_GW08	8/09/2020	17.7
Temperature	°C	DG_A_I_PZ_GW08	19/10/2020	17.7
Temperature	°C	DG_A_I_PZ_GW08	26/11/2020	18.1
Temperature	°C	DG_A_I_PZ_GW08	10/12/2020	17.8
Temperature	°C	DG_A_I_PZ_BW36A	7/07/2020	14.9
Temperature	°C	DG_A_I_PZ_BW36A	17/08/2020	16.3
Temperature	°C	DG_A_I_PZ_BW36A	7/09/2020	21
Temperature	°C	DG_A_I_PZ_BW36A	19/10/2020	16.5
Temperature	°C	DG_A_I_PZ_BW36A	25/11/2020	25
Temperature	°C	DG_A_I_PZ_BW36A	9/12/2020	21.3
Temperature	°C	DG_A_I_PZ_GW04A	30/11/2020	18.4
Temperature	°C	DG_A_I_PZ_GW04A	10/12/2020	17.7

Appendix D: Monitoring Data (Lab) – Surface water

Variable	Unit	Sample Point	Date	Result
Alkalinity (Bicarbonate) as CaCO3	mg/L	DG_A_I_SW_DUSW05B	17/09/2020	21.000
Alkalinity (Bicarbonate) as CaCO3	mg/L	DG_A_I_SW_DUSW05B	13/10/2020	48.000
Alkalinity (Bicarbonate) as CaCO3	mg/L	DG_A_I_SW_DUSW14	15/07/2020	160.000
Alkalinity (Bicarbonate) as CaCO3	mg/L	DG_A_I_SW_DUSW14	6/10/2020	180.000
Alkalinity (Bicarbonate) as CaCO3	mg/L	DG_A_I_SW_DUSW19	26/11/2020	64.000
Alkalinity (Bicarbonate) as CaCO3	mg/L	DG_A_I_SW_DUSW20	14/09/2020	41.000
Alkalinity (Bicarbonate) as CaCO3	mg/L	DG_A_I_SW_DUSW20	8/10/2020	220.000
Alkalinity (Bicarbonate) as CaCO3	mg/L	DG_A_I_SW_DUSW22	15/07/2020	120.000
Alkalinity (Bicarbonate) as CaCO3	mg/L	DG_A_I_SW_DUSW22	6/10/2020	150.000
Alkalinity (Bicarbonate) as CaCO3	mg/L	DG_A_I_SW_DUSW24	17/09/2020	51.000
Alkalinity (Bicarbonate) as CaCO3	mg/L	DG_A_I_SW_DUSW24	13/10/2020	120.000
Alkalinity (Carbonate) as CaCO3	mg/L	DG_A_I_SW_DUSW05B	17/09/2020	52.000
Alkalinity (Carbonate) as CaCO3	mg/L	DG_A_I_SW_DUSW05B	13/10/2020	60.000
Alkalinity (Carbonate) as CaCO3	mg/L	DG_A_I_SW_DUSW14	15/07/2020	0.000
Alkalinity (Carbonate) as CaCO3	mg/L	DG_A_I_SW_DUSW14	6/10/2020	0.000
Alkalinity (Carbonate) as CaCO3	mg/L	DG_A_I_SW_DUSW19	26/11/2020	0.000
Alkalinity (Carbonate) as CaCO3	mg/L	DG_A_I_SW_DUSW20	14/09/2020	0.000
Alkalinity (Carbonate) as CaCO3	mg/L	DG_A_I_SW_DUSW20	8/10/2020	14.000
Alkalinity (Carbonate) as CaCO3	mg/L	DG_A_I_SW_DUSW22	15/07/2020	0.000
Alkalinity (Carbonate) as CaCO3	mg/L	DG_A_I_SW_DUSW22	6/10/2020	0.000
Alkalinity (Carbonate) as CaCO3	mg/L	DG_A_I_SW_DUSW24	17/09/2020	20.000
Alkalinity (Carbonate) as CaCO3	mg/L	DG_A_I_SW_DUSW24	13/10/2020	31.000
Alkalinity (Hydroxide) as CaCO3	mg/L	DG_A_I_SW_DUSW05B	13/10/2020	0.000
Alkalinity (Hydroxide) as CaCO3	mg/L	DG_A_I_SW_DUSW19	26/11/2020	0.000
Alkalinity (Hydroxide) as CaCO3	mg/L	DG_A_I_SW_DUSW24	13/10/2020	0.000
Alkalinity (Hydroxide) as OH	mg/L	DG_A_I_SW_DUSW05B	17/09/2020	0.000
Alkalinity (Hydroxide) as OH	mg/L	DG_A_I_SW_DUSW14	15/07/2020	0.000
Alkalinity (Hydroxide) as OH	mg/L	DG_A_I_SW_DUSW14	6/10/2020	0.000
Alkalinity (Hydroxide) as OH	mg/L	DG_A_I_SW_DUSW20	14/09/2020	0.000
Alkalinity (Hydroxide) as OH	mg/L	DG_A_I_SW_DUSW20	8/10/2020	0.000
Alkalinity (Hydroxide) as OH	mg/L	DG_A_I_SW_DUSW22	15/07/2020	0.000
Alkalinity (Hydroxide) as OH	mg/L	DG_A_I_SW_DUSW22	6/10/2020	0.000
Alkalinity (Hydroxide) as OH	mg/L	DG_A_I_SW_DUSW24	17/09/2020	0.000
Alkalinity (Total) as CaCO3	mg/L	DG_A_I_SW_DUSW05B	13/10/2020	110.000
Alkalinity (Total) as CaCO3	mg/L	DG_A_I_SW_DUSW19	26/11/2020	64.000
Alkalinity (Total) as CaCO3	mg/L	DG_A_I_SW_DUSW24	13/10/2020	150.000
Aluminium (Total)	mg/L	DG_A_I_SW_DUSW05B	17/09/2020	0.010
Aluminium (Total)	mg/L	DG_A_I_SW_DUSW05B	13/10/2020	3.200
Aluminium (Total)	mg/L	DG_A_I_SW_DUSW11	8/10/2020	7.800
Aluminium (Total)	mg/L	DG_A_I_SW_DUSW14	15/07/2020	0.320
Aluminium (Total)	mg/L	DG_A_I_SW_DUSW14	6/10/2020	2.100
Aluminium (Total)	mg/L	DG_A_I_SW_DUSW19	26/11/2020	0.860

Variable	Unit	Sample Point	Date	Result
Aluminium (Total)	mg/L	DG_A_I_SW_DUSW20	14/09/2020	22.000
Aluminium (Total)	mg/L	DG_A_I_SW_DUSW20	8/10/2020	0.210
Aluminium (Total)	mg/L	DG_A_I_SW_DUSW22	15/07/2020	0.120
Aluminium (Total)	mg/L	DG_A_I_SW_DUSW22	6/10/2020	0.070
Aluminium (Total)	mg/L	DG_A_I_SW_DUSW24	17/09/2020	0.140
Aluminium (Total)	mg/L	DG_A_I_SW_DUSW24	13/10/2020	0.050
Aluminium (Total)	mg/L	DG_A_I_SW_DUSW25	8/10/2020	63.000
Aluminium (Total)	mg/L	DG_A_I_SW_DUSW27	8/10/2020	5.900
Ammonia Nitrogen	mg/L	DG_A_I_SW_DUSW05B	17/09/2020	0.030
Ammonia Nitrogen	mg/L	DG_A_I_SW_DUSW14	15/07/2020	0.024
Ammonia Nitrogen	mg/L	DG_A_I_SW_DUSW14	6/10/2020	0.020
Ammonia Nitrogen	mg/L	DG_A_I_SW_DUSW20	14/09/2020	0.056
Ammonia Nitrogen	mg/L	DG_A_I_SW_DUSW20	8/10/2020	0.330
Ammonia Nitrogen	mg/L	DG_A_I_SW_DUSW22	15/07/2020	0.020
Ammonia Nitrogen	mg/L	DG_A_I_SW_DUSW22	6/10/2020	0.020
Ammonia Nitrogen	mg/L	DG_A_I_SW_DUSW24	17/09/2020	0.210
Anions (Total)	meq/L	DG_A_I_SW_DUSW05B	17/09/2020	2600.000
Anions (Total)	meq/L	DG_A_I_SW_DUSW05B	13/10/2020	2800.000
Anions (Total)	meq/L	DG_A_I_SW_DUSW14	15/07/2020	66.000
Anions (Total)	meq/L	DG_A_I_SW_DUSW14	6/10/2020	49.000
Anions (Total)	meq/L	DG_A_I_SW_DUSW19	26/11/2020	6.200
Anions (Total)	meq/L	DG_A_I_SW_DUSW20	14/09/2020	2.000
Anions (Total)	meq/L	DG_A_I_SW_DUSW20	8/10/2020	120.000
Anions (Total)	meq/L	DG_A_I_SW_DUSW22	15/07/2020	93.000
Anions (Total)	meq/L	DG_A_I_SW_DUSW22	6/10/2020	72.000
Anions (Total)	meq/L	DG_A_I_SW_DUSW24	17/09/2020	160.000
Anions (Total)	meq/L	DG_A_I_SW_DUSW24	13/10/2020	180.000
Antimony (Total)	mg/L	DG_A_I_SW_DUSW05B	17/09/2020	0.010
Antimony (Total)	mg/L	DG_A_I_SW_DUSW05B	13/10/2020	0.010
Antimony (Total)	mg/L	DG_A_I_SW_DUSW11	8/10/2020	0.001
Antimony (Total)	mg/L	DG_A_I_SW_DUSW14	15/07/2020	0.001
Antimony (Total)	mg/L	DG_A_I_SW_DUSW14	6/10/2020	0.001
Antimony (Total)	mg/L	DG_A_I_SW_DUSW19	26/11/2020	0.001
Antimony (Total)	mg/L	DG_A_I_SW_DUSW20	14/09/2020	0.001
Antimony (Total)	mg/L	DG_A_I_SW_DUSW20	8/10/2020	0.001
Antimony (Total)	mg/L	DG_A_I_SW_DUSW22	15/07/2020	0.001
Antimony (Total)	mg/L	DG_A_I_SW_DUSW22	6/10/2020	0.001
Antimony (Total)	mg/L	DG_A_I_SW_DUSW24	17/09/2020	0.001
Antimony (Total)	mg/L	DG_A_I_SW_DUSW24	13/10/2020	0.001
Antimony (Total)	mg/L	DG_A_I_SW_DUSW25	8/10/2020	0.001
Antimony (Total)	mg/L	DG_A_I_SW_DUSW27	8/10/2020	0.001
Arsenic (Total)	mg/L	DG_A_I_SW_DUSW05B	17/09/2020	0.010
Arsenic (Total)	mg/L	DG_A_I_SW_DUSW05B	13/10/2020	0.010
Arsenic (Total)	mg/L	DG_A_I_SW_DUSW11	8/10/2020	0.003

Variable	Unit	Sample Point	Date	Result
Arsenic (Total)	mg/L	DG_A_I_SW_DUSW14	15/07/2020	0.001
Arsenic (Total)	mg/L	DG_A_I_SW_DUSW14	6/10/2020	0.001
Arsenic (Total)	mg/L	DG_A_I_SW_DUSW19	26/11/2020	0.002
Arsenic (Total)	mg/L	DG_A_I_SW_DUSW20	14/09/2020	0.007
Arsenic (Total)	mg/L	DG_A_I_SW_DUSW20	8/10/2020	0.002
Arsenic (Total)	mg/L	DG_A_I_SW_DUSW22	15/07/2020	0.001
Arsenic (Total)	mg/L	DG_A_I_SW_DUSW22	6/10/2020	0.001
Arsenic (Total)	mg/L	DG_A_I_SW_DUSW24	17/09/2020	0.011
Arsenic (Total)	mg/L	DG_A_I_SW_DUSW24	13/10/2020	0.012
Arsenic (Total)	mg/L	DG_A_I_SW_DUSW25	8/10/2020	0.011
Arsenic (Total)	mg/L	DG_A_I_SW_DUSW27	8/10/2020	0.003
Barium (Total)	mg/L	DG_A_I_SW_DUSW05B	17/09/2020	0.080
Barium (Total)	mg/L	DG_A_I_SW_DUSW05B	13/10/2020	0.090
Barium (Total)	mg/L	DG_A_I_SW_DUSW11	8/10/2020	0.031
Barium (Total)	mg/L	DG_A_I_SW_DUSW14	15/07/2020	0.081
Barium (Total)	mg/L	DG_A_I_SW_DUSW14	6/10/2020	0.046
Barium (Total)	mg/L	DG_A_I_SW_DUSW19	26/11/2020	0.044
Barium (Total)	mg/L	DG_A_I_SW_DUSW20	14/09/2020	0.028
Barium (Total)	mg/L	DG_A_I_SW_DUSW20	8/10/2020	0.110
Barium (Total)	mg/L	DG_A_I_SW_DUSW22	15/07/2020	0.072
Barium (Total)	mg/L	DG_A_I_SW_DUSW22	6/10/2020	0.051
Barium (Total)	mg/L	DG_A_I_SW_DUSW24	17/09/2020	0.180
Barium (Total)	mg/L	DG_A_I_SW_DUSW24	13/10/2020	0.230
Barium (Total)	mg/L	DG_A_I_SW_DUSW25	8/10/2020	0.056
Barium (Total)	mg/L	DG_A_I_SW_DUSW27	8/10/2020	0.028
Beryllium (Total)	mg/L	DG_A_I_SW_DUSW05B	17/09/2020	0.010
Beryllium (Total)	mg/L	DG_A_I_SW_DUSW05B	13/10/2020	0.010
Beryllium (Total)	mg/L	DG_A_I_SW_DUSW11	8/10/2020	0.001
Beryllium (Total)	mg/L	DG_A_I_SW_DUSW14	15/07/2020	0.001
Beryllium (Total)	mg/L	DG_A_I_SW_DUSW14	6/10/2020	0.001
Beryllium (Total)	mg/L	DG_A_I_SW_DUSW19	26/11/2020	0.001
Beryllium (Total)	mg/L	DG_A_I_SW_DUSW20	14/09/2020	0.001
Beryllium (Total)	mg/L	DG_A_I_SW_DUSW20	8/10/2020	0.001
Beryllium (Total)	mg/L	DG_A_I_SW_DUSW22	15/07/2020	0.001
Beryllium (Total)	mg/L	DG_A_I_SW_DUSW22	6/10/2020	0.001
Beryllium (Total)	mg/L	DG_A_I_SW_DUSW24	17/09/2020	0.001
Beryllium (Total)	mg/L	DG_A_I_SW_DUSW24	13/10/2020	0.001
Beryllium (Total)	mg/L	DG_A_I_SW_DUSW25	8/10/2020	0.001
Beryllium (Total)	mg/L	DG_A_I_SW_DUSW27	8/10/2020	0.001
Boron (Total)	mg/L	DG_A_I_SW_DUSW05B	17/09/2020	2.900
Boron (Total)	mg/L	DG_A_I_SW_DUSW05B	13/10/2020	3.200
Boron (Total)	mg/L	DG_A_I_SW_DUSW11	8/10/2020	0.100
Boron (Total)	mg/L	DG_A_I_SW_DUSW14	15/07/2020	0.250
Boron (Total)	mg/L	DG_A_I_SW_DUSW14	6/10/2020	0.250

Variable	Unit	Sample Point	Date	Result
Boron (Total)	mg/L	DG_A_I_SW_DUSW19	26/11/2020	0.140
Boron (Total)	mg/L	DG_A_I_SW_DUSW20	14/09/2020	0.110
Boron (Total)	mg/L	DG_A_I_SW_DUSW20	8/10/2020	0.320
Boron (Total)	mg/L	DG_A_I_SW_DUSW22	15/07/2020	0.140
Boron (Total)	mg/L	DG_A_I_SW_DUSW22	6/10/2020	0.140
Boron (Total)	mg/L	DG_A_I_SW_DUSW24	17/09/2020	2.400
Boron (Total)	mg/L	DG_A_I_SW_DUSW24	13/10/2020	2.800
Boron (Total)	mg/L	DG_A_I_SW_DUSW25	8/10/2020	0.080
Boron (Total)	mg/L	DG_A_I_SW_DUSW27	8/10/2020	0.090
Cadmium (Total)	mg/L	DG_A_I_SW_DUSW05B	17/09/2020	0.002
Cadmium (Total)	mg/L	DG_A_I_SW_DUSW05B	13/10/2020	0.002
Cadmium (Total)	mg/L	DG_A_I_SW_DUSW11	8/10/2020	0.000
Cadmium (Total)	mg/L	DG_A_I_SW_DUSW14	15/07/2020	0.000
Cadmium (Total)	mg/L	DG_A_I_SW_DUSW14	6/10/2020	0.000
Cadmium (Total)	mg/L	DG_A_I_SW_DUSW19	26/11/2020	0.000
Cadmium (Total)	mg/L	DG_A_I_SW_DUSW20	14/09/2020	0.000
Cadmium (Total)	mg/L	DG_A_I_SW_DUSW20	8/10/2020	0.000
Cadmium (Total)	mg/L	DG_A_I_SW_DUSW22	15/07/2020	0.000
Cadmium (Total)	mg/L	DG_A_I_SW_DUSW22	6/10/2020	0.000
Cadmium (Total)	mg/L	DG_A_I_SW_DUSW24	17/09/2020	0.000
Cadmium (Total)	mg/L	DG_A_I_SW_DUSW24	13/10/2020	0.000
Cadmium (Total)	mg/L	DG_A_I_SW_DUSW25	8/10/2020	0.000
Cadmium (Total)	mg/L	DG_A_I_SW_DUSW27	8/10/2020	0.000
Calcium	mg/L	DG_A_I_SW_DUSW05B	17/09/2020	1700.000
Calcium	mg/L	DG_A_I_SW_DUSW05B	13/10/2020	1700.000
Calcium	mg/L	DG_A_I_SW_DUSW14	15/07/2020	74.000
Calcium	mg/L	DG_A_I_SW_DUSW14	6/10/2020	54.000
Calcium	mg/L	DG_A_I_SW_DUSW19	26/11/2020	13.000
Calcium	mg/L	DG_A_I_SW_DUSW20	14/09/2020	5.500
Calcium	mg/L	DG_A_I_SW_DUSW20	8/10/2020	180.000
Calcium	mg/L	DG_A_I_SW_DUSW22	15/07/2020	140.000
Calcium	mg/L	DG_A_I_SW_DUSW22	6/10/2020	120.000
Calcium	mg/L	DG_A_I_SW_DUSW24	17/09/2020	340.000
Calcium	mg/L	DG_A_I_SW_DUSW24	13/10/2020	360.000
Cations (Total)	meq/L	DG_A_I_SW_DUSW05B	17/09/2020	2800.000
Cations (Total)	meq/L	DG_A_I_SW_DUSW05B	13/10/2020	2700.000
Cations (Total)	meq/L	DG_A_I_SW_DUSW14	15/07/2020	73.000
Cations (Total)	meq/L	DG_A_I_SW_DUSW14	6/10/2020	49.000
Cations (Total)	meq/L	DG_A_I_SW_DUSW19	26/11/2020	7.000
Cations (Total)	meq/L	DG_A_I_SW_DUSW20	14/09/2020	2.900
Cations (Total)	meq/L	DG_A_I_SW_DUSW20	8/10/2020	120.000
Cations (Total)	meq/L	DG_A_I_SW_DUSW22	15/07/2020	98.000
Cations (Total)	meq/L	DG_A_I_SW_DUSW22	6/10/2020	70.000
Cations (Total)	meq/L	DG_A_I_SW_DUSW24	17/09/2020	160.000

Variable	Unit	Sample Point	Date	Result
Cations (Total)	meq/L	DG_A_I_SW_DUSW24	13/10/2020	170.000
Chloride	mg/L	DG_A_I_SW_DUSW05B	17/09/2020	86000.000
Chloride	mg/L	DG_A_I_SW_DUSW05B	13/10/2020	94000.000
Chloride	mg/L	DG_A_I_SW_DUSW14	15/07/2020	2100.000
Chloride	mg/L	DG_A_I_SW_DUSW14	6/10/2020	1400.000
Chloride	mg/L	DG_A_I_SW_DUSW19	26/11/2020	110.000
Chloride	mg/L	DG_A_I_SW_DUSW20	14/09/2020	42.000
Chloride	mg/L	DG_A_I_SW_DUSW20	8/10/2020	3700.000
Chloride	mg/L	DG_A_I_SW_DUSW22	15/07/2020	3000.000
Chloride	mg/L	DG_A_I_SW_DUSW22	6/10/2020	2300.000
Chloride	mg/L	DG_A_I_SW_DUSW24	17/09/2020	4800.000
Chloride	mg/L	DG_A_I_SW_DUSW24	13/10/2020	5500.000
Chromium (Total)	mg/L	DG_A_I_SW_DUSW05B	17/09/2020	0.010
Chromium (Total)	mg/L	DG_A_I_SW_DUSW05B	13/10/2020	0.010
Chromium (Total)	mg/L	DG_A_I_SW_DUSW11	8/10/2020	0.007
Chromium (Total)	mg/L	DG_A_I_SW_DUSW14	15/07/2020	0.001
Chromium (Total)	mg/L	DG_A_I_SW_DUSW14	6/10/2020	0.002
Chromium (Total)	mg/L	DG_A_I_SW_DUSW19	26/11/2020	0.001
Chromium (Total)	mg/L	DG_A_I_SW_DUSW20	14/09/2020	0.021
Chromium (Total)	mg/L	DG_A_I_SW_DUSW20	8/10/2020	0.001
Chromium (Total)	mg/L	DG_A_I_SW_DUSW22	15/07/2020	0.001
Chromium (Total)	mg/L	DG_A_I_SW_DUSW22	6/10/2020	0.001
Chromium (Total)	mg/L	DG_A_I_SW_DUSW24	17/09/2020	0.001
Chromium (Total)	mg/L	DG_A_I_SW_DUSW24	13/10/2020	0.002
Chromium (Total)	mg/L	DG_A_I_SW_DUSW25	8/10/2020	0.062
Chromium (Total)	mg/L	DG_A_I_SW_DUSW27	8/10/2020	0.005
Cobalt (Total)	mg/L	DG_A_I_SW_DUSW05B	17/09/2020	0.010
Cobalt (Total)	mg/L	DG_A_I_SW_DUSW05B	13/10/2020	0.010
Cobalt (Total)	mg/L	DG_A_I_SW_DUSW11	8/10/2020	0.002
Cobalt (Total)	mg/L	DG_A_I_SW_DUSW14	15/07/2020	0.001
Cobalt (Total)	mg/L	DG_A_I_SW_DUSW14	6/10/2020	0.001
Cobalt (Total)	mg/L	DG_A_I_SW_DUSW19	26/11/2020	0.001
Cobalt (Total)	mg/L	DG_A_I_SW_DUSW20	14/09/2020	0.003
Cobalt (Total)	mg/L	DG_A_I_SW_DUSW20	8/10/2020	0.001
Cobalt (Total)	mg/L	DG_A_I_SW_DUSW22	15/07/2020	0.001
Cobalt (Total)	mg/L	DG_A_I_SW_DUSW22	6/10/2020	0.001
Cobalt (Total)	mg/L	DG_A_I_SW_DUSW24	17/09/2020	0.001
Cobalt (Total)	mg/L	DG_A_I_SW_DUSW24	13/10/2020	0.001
Cobalt (Total)	mg/L	DG_A_I_SW_DUSW25	8/10/2020	0.006
Cobalt (Total)	mg/L	DG_A_I_SW_DUSW27	8/10/2020	0.002
Copper (Total)	mg/L	DG_A_I_SW_DUSW05B	17/09/2020	0.010
Copper (Total)	mg/L	DG_A_I_SW_DUSW05B	13/10/2020	0.010
Copper (Total)	mg/L	DG_A_I_SW_DUSW11	8/10/2020	0.010
Copper (Total)	mg/L	DG_A_I_SW_DUSW14	15/07/2020	0.001

Variable	Unit	Sample Point	Date	Result
Copper (Total)	mg/L	DG_A_I_SW_DUSW14	6/10/2020	0.002
Copper (Total)	mg/L	DG_A_I_SW_DUSW19	26/11/2020	0.001
Copper (Total)	mg/L	DG_A_I_SW_DUSW20	14/09/2020	0.005
Copper (Total)	mg/L	DG_A_I_SW_DUSW20	8/10/2020	0.001
Copper (Total)	mg/L	DG_A_I_SW_DUSW22	15/07/2020	0.002
Copper (Total)	mg/L	DG_A_I_SW_DUSW22	6/10/2020	0.001
Copper (Total)	mg/L	DG_A_I_SW_DUSW24	17/09/2020	0.008
Copper (Total)	mg/L	DG_A_I_SW_DUSW24	13/10/2020	0.004
Copper (Total)	mg/L	DG_A_I_SW_DUSW25	8/10/2020	0.003
Copper (Total)	mg/L	DG_A_I_SW_DUSW27	8/10/2020	0.006
Electrical Conductivity	µS/cm	DG_A_I_SW_DUSW05B	17/09/2020	17000.000
Electrical Conductivity	µS/cm	DG_A_I_SW_DUSW05B	13/10/2020	18000.000
Electrical Conductivity	µS/cm	DG_A_I_SW_DUSW11	8/10/2020	78.000
Electrical Conductivity	µS/cm	DG_A_I_SW_DUSW14	15/07/2020	7400.000
Electrical Conductivity	µS/cm	DG_A_I_SW_DUSW14	6/10/2020	5200.000
Electrical Conductivity	µS/cm	DG_A_I_SW_DUSW17	7/10/2020	300.000
Electrical Conductivity	µS/cm	DG_A_I_SW_DUSW19	7/10/2020	900.000
Electrical Conductivity	µS/cm	DG_A_I_SW_DUSW19	26/11/2020	840.000
Electrical Conductivity	µS/cm	DG_A_I_SW_DUSW20	14/09/2020	260.000
Electrical Conductivity	µS/cm	DG_A_I_SW_DUSW20	8/10/2020	12000.000
Electrical Conductivity	µS/cm	DG_A_I_SW_DUSW22	15/07/2020	9600.000
Electrical Conductivity	µS/cm	DG_A_I_SW_DUSW22	6/10/2020	7400.000
Electrical Conductivity	µS/cm	DG_A_I_SW_DUSW24	17/09/2020	15000.000
Electrical Conductivity	µS/cm	DG_A_I_SW_DUSW24	13/10/2020	18000.000
Electrical Conductivity	µS/cm	DG_A_I_SW_DUSW25	8/10/2020	190.000
Electrical Conductivity	µS/cm	DG_A_I_SW_DUSW26	6/10/2020	230.000
Electrical Conductivity	µS/cm	DG_A_I_SW_DUSW27	20/08/2020	210.000
Electrical Conductivity	µS/cm	DG_A_I_SW_DUSW27	8/10/2020	130.000
Fluoride	mg/L	DG_A_I_SW_DUSW05B	17/09/2020	1.000
Fluoride	mg/L	DG_A_I_SW_DUSW05B	13/10/2020	1.000
Fluoride	mg/L	DG_A_I_SW_DUSW14	15/07/2020	0.210
Fluoride	mg/L	DG_A_I_SW_DUSW14	6/10/2020	0.220
Fluoride	mg/L	DG_A_I_SW_DUSW19	26/11/2020	0.450
Fluoride	mg/L	DG_A_I_SW_DUSW20	14/09/2020	0.100
Fluoride	mg/L	DG_A_I_SW_DUSW20	8/10/2020	0.210
Fluoride	mg/L	DG_A_I_SW_DUSW22	15/07/2020	0.370
Fluoride	mg/L	DG_A_I_SW_DUSW22	6/10/2020	0.430
Fluoride	mg/L	DG_A_I_SW_DUSW24	17/09/2020	0.190
Fluoride	mg/L	DG_A_I_SW_DUSW24	13/10/2020	0.140
Iron (Total)	mg/L	DG_A_I_SW_DUSW05B	17/09/2020	0.010
Iron (Total)	mg/L	DG_A_I_SW_DUSW05B	13/10/2020	2.200
Iron (Total)	mg/L	DG_A_I_SW_DUSW11	8/10/2020	5.600
Iron (Total)	mg/L	DG_A_I_SW_DUSW14	15/07/2020	1.000
Iron (Total)	mg/L	DG_A_I_SW_DUSW14	6/10/2020	2.100

Variable	Unit	Sample Point	Date	Result
Iron (Total)	mg/L	DG_A_I_SW_DUSW19	26/11/2020	0.970
Iron (Total)	mg/L	DG_A_I_SW_DUSW20	14/09/2020	14.000
Iron (Total)	mg/L	DG_A_I_SW_DUSW20	8/10/2020	0.200
Iron (Total)	mg/L	DG_A_I_SW_DUSW22	15/07/2020	0.320
Iron (Total)	mg/L	DG_A_I_SW_DUSW22	6/10/2020	0.380
Iron (Total)	mg/L	DG_A_I_SW_DUSW24	17/09/2020	0.140
Iron (Total)	mg/L	DG_A_I_SW_DUSW24	13/10/2020	0.050
Iron (Total)	mg/L	DG_A_I_SW_DUSW25	8/10/2020	37.000
Iron (Total)	mg/L	DG_A_I_SW_DUSW27	8/10/2020	4.600
Lead (Total)	mg/L	DG_A_I_SW_DUSW05B	17/09/2020	0.010
Lead (Total)	mg/L	DG_A_I_SW_DUSW05B	13/10/2020	0.010
Lead (Total)	mg/L	DG_A_I_SW_DUSW11	8/10/2020	0.003
Lead (Total)	mg/L	DG_A_I_SW_DUSW14	15/07/2020	0.001
Lead (Total)	mg/L	DG_A_I_SW_DUSW14	6/10/2020	0.001
Lead (Total)	mg/L	DG_A_I_SW_DUSW19	26/11/2020	0.001
Lead (Total)	mg/L	DG_A_I_SW_DUSW20	14/09/2020	0.008
Lead (Total)	mg/L	DG_A_I_SW_DUSW20	8/10/2020	0.001
Lead (Total)	mg/L	DG_A_I_SW_DUSW22	15/07/2020	0.001
Lead (Total)	mg/L	DG_A_I_SW_DUSW22	6/10/2020	0.001
Lead (Total)	mg/L	DG_A_I_SW_DUSW24	17/09/2020	0.004
Lead (Total)	mg/L	DG_A_I_SW_DUSW24	13/10/2020	0.001
Lead (Total)	mg/L	DG_A_I_SW_DUSW25	8/10/2020	0.014
Lead (Total)	mg/L	DG_A_I_SW_DUSW27	8/10/2020	0.002
Magnesium	mg/L	DG_A_I_SW_DUSW05B	17/09/2020	3700.000
Magnesium	mg/L	DG_A_I_SW_DUSW05B	13/10/2020	4000.000
Magnesium	mg/L	DG_A_I_SW_DUSW14	15/07/2020	120.000
Magnesium	mg/L	DG_A_I_SW_DUSW14	6/10/2020	82.000
Magnesium	mg/L	DG_A_I_SW_DUSW19	26/11/2020	10.000
Magnesium	mg/L	DG_A_I_SW_DUSW20	14/09/2020	5.100
Magnesium	mg/L	DG_A_I_SW_DUSW20	8/10/2020	210.000
Magnesium	mg/L	DG_A_I_SW_DUSW22	15/07/2020	240.000
Magnesium	mg/L	DG_A_I_SW_DUSW22	6/10/2020	170.000
Magnesium	mg/L	DG_A_I_SW_DUSW24	17/09/2020	230.000
Magnesium	mg/L	DG_A_I_SW_DUSW24	13/10/2020	260.000
Manganese (Total)	mg/L	DG_A_I_SW_DUSW05B	17/09/2020	0.010
Manganese (Total)	mg/L	DG_A_I_SW_DUSW05B	13/10/2020	0.130
Manganese (Total)	mg/L	DG_A_I_SW_DUSW11	8/10/2020	0.027
Manganese (Total)	mg/L	DG_A_I_SW_DUSW14	15/07/2020	0.160
Manganese (Total)	mg/L	DG_A_I_SW_DUSW14	6/10/2020	0.057
Manganese (Total)	mg/L	DG_A_I_SW_DUSW19	26/11/2020	0.022
Manganese (Total)	mg/L	DG_A_I_SW_DUSW20	14/09/2020	0.070
Manganese (Total)	mg/L	DG_A_I_SW_DUSW20	8/10/2020	0.072
Manganese (Total)	mg/L	DG_A_I_SW_DUSW22	15/07/2020	0.027
Manganese (Total)	mg/L	DG_A_I_SW_DUSW22	6/10/2020	0.030

Variable	Unit	Sample Point	Date	Result
Manganese (Total)	mg/L	DG_A_I_SW_DUSW24	17/09/2020	0.120
Manganese (Total)	mg/L	DG_A_I_SW_DUSW24	13/10/2020	0.110
Manganese (Total)	mg/L	DG_A_I_SW_DUSW25	8/10/2020	0.046
Manganese (Total)	mg/L	DG_A_I_SW_DUSW27	8/10/2020	0.020
Mercury (Total)	mg/L	DG_A_I_SW_DUSW05B	17/09/2020	0.000
Mercury (Total)	mg/L	DG_A_I_SW_DUSW05B	13/10/2020	0.001
Mercury (Total)	mg/L	DG_A_I_SW_DUSW11	8/10/2020	0.000
Mercury (Total)	mg/L	DG_A_I_SW_DUSW14	15/07/2020	0.000
Mercury (Total)	mg/L	DG_A_I_SW_DUSW14	6/10/2020	0.000
Mercury (Total)	mg/L	DG_A_I_SW_DUSW19	26/11/2020	0.000
Mercury (Total)	mg/L	DG_A_I_SW_DUSW20	14/09/2020	0.000
Mercury (Total)	mg/L	DG_A_I_SW_DUSW20	8/10/2020	0.000
Mercury (Total)	mg/L	DG_A_I_SW_DUSW22	15/07/2020	0.000
Mercury (Total)	mg/L	DG_A_I_SW_DUSW22	6/10/2020	0.000
Mercury (Total)	mg/L	DG_A_I_SW_DUSW24	17/09/2020	0.000
Mercury (Total)	mg/L	DG_A_I_SW_DUSW24	13/10/2020	0.000
Mercury (Total)	mg/L	DG_A_I_SW_DUSW25	8/10/2020	0.000
Mercury (Total)	mg/L	DG_A_I_SW_DUSW27	8/10/2020	0.000
Molybdenum (Total)	mg/L	DG_A_I_SW_DUSW05B	17/09/2020	0.010
Molybdenum (Total)	mg/L	DG_A_I_SW_DUSW05B	13/10/2020	0.010
Molybdenum (Total)	mg/L	DG_A_I_SW_DUSW11	8/10/2020	0.002
Molybdenum (Total)	mg/L	DG_A_I_SW_DUSW14	15/07/2020	0.001
Molybdenum (Total)	mg/L	DG_A_I_SW_DUSW14	6/10/2020	0.001
Molybdenum (Total)	mg/L	DG_A_I_SW_DUSW19	26/11/2020	0.001
Molybdenum (Total)	mg/L	DG_A_I_SW_DUSW20	14/09/2020	0.001
Molybdenum (Total)	mg/L	DG_A_I_SW_DUSW20	8/10/2020	0.001
Molybdenum (Total)	mg/L	DG_A_I_SW_DUSW22	15/07/2020	0.001
Molybdenum (Total)	mg/L	DG_A_I_SW_DUSW22	6/10/2020	0.001
Molybdenum (Total)	mg/L	DG_A_I_SW_DUSW24	17/09/2020	0.004
Molybdenum (Total)	mg/L	DG_A_I_SW_DUSW24	13/10/2020	0.002
Molybdenum (Total)	mg/L	DG_A_I_SW_DUSW25	8/10/2020	0.001
Molybdenum (Total)	mg/L	DG_A_I_SW_DUSW27	8/10/2020	0.001
Nickel (Total)	mg/L	DG_A_I_SW_DUSW05B	17/09/2020	0.010
Nickel (Total)	mg/L	DG_A_I_SW_DUSW05B	13/10/2020	0.010
Nickel (Total)	mg/L	DG_A_I_SW_DUSW11	8/10/2020	0.004
Nickel (Total)	mg/L	DG_A_I_SW_DUSW14	15/07/2020	0.001
Nickel (Total)	mg/L	DG_A_I_SW_DUSW14	6/10/2020	0.001
Nickel (Total)	mg/L	DG_A_I_SW_DUSW19	26/11/2020	0.001
Nickel (Total)	mg/L	DG_A_I_SW_DUSW20	14/09/2020	0.010
Nickel (Total)	mg/L	DG_A_I_SW_DUSW20	8/10/2020	0.001
Nickel (Total)	mg/L	DG_A_I_SW_DUSW22	15/07/2020	0.001
Nickel (Total)	mg/L	DG_A_I_SW_DUSW22	6/10/2020	0.002
Nickel (Total)	mg/L	DG_A_I_SW_DUSW24	17/09/2020	0.003
Nickel (Total)	mg/L	DG_A_I_SW_DUSW24	13/10/2020	0.002

Variable	Unit	Sample Point	Date	Result
Nickel (Total)	mg/L	DG_A_I_SW_DUSW25	8/10/2020	0.015
Nickel (Total)	mg/L	DG_A_I_SW_DUSW27	8/10/2020	0.003
Nitrate-Nitrogen	mg/L	DG_A_I_SW_DUSW05B	17/09/2020	0.005
Nitrate-Nitrogen	mg/L	DG_A_I_SW_DUSW05B	13/10/2020	0.005
Nitrate-Nitrogen	mg/L	DG_A_I_SW_DUSW11	8/10/2020	0.470
Nitrate-Nitrogen	mg/L	DG_A_I_SW_DUSW14	15/07/2020	0.045
Nitrate-Nitrogen	mg/L	DG_A_I_SW_DUSW14	6/10/2020	0.005
Nitrate-Nitrogen	mg/L	DG_A_I_SW_DUSW17	7/10/2020	0.580
Nitrate-Nitrogen	mg/L	DG_A_I_SW_DUSW19	7/10/2020	0.035
Nitrate-Nitrogen	mg/L	DG_A_I_SW_DUSW19	26/11/2020	0.013
Nitrate-Nitrogen	mg/L	DG_A_I_SW_DUSW20	14/09/2020	0.005
Nitrate-Nitrogen	mg/L	DG_A_I_SW_DUSW20	8/10/2020	0.005
Nitrate-Nitrogen	mg/L	DG_A_I_SW_DUSW22	15/07/2020	0.005
Nitrate-Nitrogen	mg/L	DG_A_I_SW_DUSW22	6/10/2020	0.005
Nitrate-Nitrogen	mg/L	DG_A_I_SW_DUSW24	17/09/2020	0.005
Nitrate-Nitrogen	mg/L	DG_A_I_SW_DUSW24	13/10/2020	0.082
Nitrate-Nitrogen	mg/L	DG_A_I_SW_DUSW25	8/10/2020	0.250
Nitrate-Nitrogen	mg/L	DG_A_I_SW_DUSW26	6/10/2020	0.580
Nitrate-Nitrogen	mg/L	DG_A_I_SW_DUSW27	20/08/2020	0.240
Nitrate-Nitrogen	mg/L	DG_A_I_SW_DUSW27	8/10/2020	0.130
Nitrite-Nitrogen	mg/L	DG_A_I_SW_DUSW05B	17/09/2020	0.100
Nitrite-Nitrogen	mg/L	DG_A_I_SW_DUSW05B	13/10/2020	0.001
Nitrite-Nitrogen	mg/L	DG_A_I_SW_DUSW11	8/10/2020	0.010
Nitrite-Nitrogen	mg/L	DG_A_I_SW_DUSW14	15/07/2020	0.003
Nitrite-Nitrogen	mg/L	DG_A_I_SW_DUSW14	6/10/2020	0.001
Nitrite-Nitrogen	mg/L	DG_A_I_SW_DUSW17	7/10/2020	0.036
Nitrite-Nitrogen	mg/L	DG_A_I_SW_DUSW19	7/10/2020	0.005
Nitrite-Nitrogen	mg/L	DG_A_I_SW_DUSW19	26/11/2020	0.006
Nitrite-Nitrogen	mg/L	DG_A_I_SW_DUSW20	14/09/2020	0.010
Nitrite-Nitrogen	mg/L	DG_A_I_SW_DUSW20	8/10/2020	0.001
Nitrite-Nitrogen	mg/L	DG_A_I_SW_DUSW22	15/07/2020	0.001
Nitrite-Nitrogen	mg/L	DG_A_I_SW_DUSW22	6/10/2020	0.001
Nitrite-Nitrogen	mg/L	DG_A_I_SW_DUSW24	17/09/2020	0.001
Nitrite-Nitrogen	mg/L	DG_A_I_SW_DUSW24	13/10/2020	0.004
Nitrite-Nitrogen	mg/L	DG_A_I_SW_DUSW25	8/10/2020	0.024
Nitrite-Nitrogen	mg/L	DG_A_I_SW_DUSW26	6/10/2020	0.028
Nitrite-Nitrogen	mg/L	DG_A_I_SW_DUSW27	20/08/2020	0.016
Nitrite-Nitrogen	mg/L	DG_A_I_SW_DUSW27	8/10/2020	0.012
Nitrogen (Total)	mg/L	DG_A_I_SW_DUSW05B	17/09/2020	1.000
Nitrogen (Total)	mg/L	DG_A_I_SW_DUSW05B	13/10/2020	1.400
Nitrogen (Total)	mg/L	DG_A_I_SW_DUSW11	8/10/2020	2.800
Nitrogen (Total)	mg/L	DG_A_I_SW_DUSW14	15/07/2020	0.840
Nitrogen (Total)	mg/L	DG_A_I_SW_DUSW14	6/10/2020	0.770
Nitrogen (Total)	mg/L	DG_A_I_SW_DUSW17	7/10/2020	2.600

Variable	Unit	Sample Point	Date	Result
Nitrogen (Total)	mg/L	DG_A_I_SW_DUSW19	7/10/2020	0.770
Nitrogen (Total)	mg/L	DG_A_I_SW_DUSW19	26/11/2020	0.780
Nitrogen (Total)	mg/L	DG_A_I_SW_DUSW20	14/09/2020	2.700
Nitrogen (Total)	mg/L	DG_A_I_SW_DUSW20	8/10/2020	1.500
Nitrogen (Total)	mg/L	DG_A_I_SW_DUSW22	15/07/2020	0.320
Nitrogen (Total)	mg/L	DG_A_I_SW_DUSW22	6/10/2020	0.370
Nitrogen (Total)	mg/L	DG_A_I_SW_DUSW23	15/07/2020	2.400
Nitrogen (Total)	mg/L	DG_A_I_SW_DUSW24	17/09/2020	6.600
Nitrogen (Total)	mg/L	DG_A_I_SW_DUSW24	13/10/2020	5.900
Nitrogen (Total)	mg/L	DG_A_I_SW_DUSW25	8/10/2020	2.000
Nitrogen (Total)	mg/L	DG_A_I_SW_DUSW26	6/10/2020	0.610
Nitrogen (Total)	mg/L	DG_A_I_SW_DUSW27	20/08/2020	4.200
Nitrogen (Total)	mg/L	DG_A_I_SW_DUSW27	8/10/2020	3.300
pH	pH units	DG_A_I_SW_DUSW05B	17/09/2020	8.400
pH	pH units	DG_A_I_SW_DUSW05B	13/10/2020	8.500
pH	pH units	DG_A_I_SW_DUSW11	8/10/2020	7.300
pH	pH units	DG_A_I_SW_DUSW14	15/07/2020	7.500
pH	pH units	DG_A_I_SW_DUSW14	6/10/2020	7.500
pH	pH units	DG_A_I_SW_DUSW17	7/10/2020	7.700
pH	pH units	DG_A_I_SW_DUSW19	7/10/2020	7.800
pH	pH units	DG_A_I_SW_DUSW19	26/11/2020	7.900
pH	pH units	DG_A_I_SW_DUSW20	14/09/2020	7.300
pH	pH units	DG_A_I_SW_DUSW20	8/10/2020	7.900
pH	pH units	DG_A_I_SW_DUSW22	15/07/2020	7.600
pH	pH units	DG_A_I_SW_DUSW22	6/10/2020	7.800
pH	pH units	DG_A_I_SW_DUSW24	17/09/2020	9.000
pH	pH units	DG_A_I_SW_DUSW24	13/10/2020	8.600
pH	pH units	DG_A_I_SW_DUSW25	8/10/2020	7.000
pH	pH units	DG_A_I_SW_DUSW26	6/10/2020	8.000
pH	pH units	DG_A_I_SW_DUSW27	20/08/2020	7.300
pH	pH units	DG_A_I_SW_DUSW27	8/10/2020	7.000
Phosphorus (Ortho)	mg/L	DG_A_I_SW_DUSW05B	17/09/2020	0.004
Phosphorus (Ortho)	mg/L	DG_A_I_SW_DUSW05B	13/10/2020	0.004
Phosphorus (Ortho)	mg/L	DG_A_I_SW_DUSW11	8/10/2020	0.015
Phosphorus (Ortho)	mg/L	DG_A_I_SW_DUSW14	15/07/2020	0.004
Phosphorus (Ortho)	mg/L	DG_A_I_SW_DUSW14	6/10/2020	0.004
Phosphorus (Ortho)	mg/L	DG_A_I_SW_DUSW19	26/11/2020	0.004
Phosphorus (Ortho)	mg/L	DG_A_I_SW_DUSW20	14/09/2020	0.057
Phosphorus (Ortho)	mg/L	DG_A_I_SW_DUSW20	8/10/2020	0.004
Phosphorus (Ortho)	mg/L	DG_A_I_SW_DUSW22	15/07/2020	0.004
Phosphorus (Ortho)	mg/L	DG_A_I_SW_DUSW22	6/10/2020	0.007
Phosphorus (Ortho)	mg/L	DG_A_I_SW_DUSW24	17/09/2020	0.007
Phosphorus (Ortho)	mg/L	DG_A_I_SW_DUSW24	13/10/2020	0.025
Phosphorus (Ortho)	mg/L	DG_A_I_SW_DUSW25	8/10/2020	0.004

Variable	Unit	Sample Point	Date	Result
Phosphorus (Ortho)	mg/L	DG_A_I_SW_DUSW27	8/10/2020	0.054
Phosphorus (Total)	mg/L	DG_A_I_SW_DUSW05B	17/09/2020	0.340
Phosphorus (Total)	mg/L	DG_A_I_SW_DUSW05B	13/10/2020	0.360
Phosphorus (Total)	mg/L	DG_A_I_SW_DUSW11	8/10/2020	0.190
Phosphorus (Total)	mg/L	DG_A_I_SW_DUSW14	15/07/2020	0.067
Phosphorus (Total)	mg/L	DG_A_I_SW_DUSW14	6/10/2020	0.039
Phosphorus (Total)	mg/L	DG_A_I_SW_DUSW17	7/10/2020	0.150
Phosphorus (Total)	mg/L	DG_A_I_SW_DUSW19	7/10/2020	0.045
Phosphorus (Total)	mg/L	DG_A_I_SW_DUSW19	26/11/2020	0.021
Phosphorus (Total)	mg/L	DG_A_I_SW_DUSW20	14/09/2020	0.110
Phosphorus (Total)	mg/L	DG_A_I_SW_DUSW20	8/10/2020	0.095
Phosphorus (Total)	mg/L	DG_A_I_SW_DUSW22	15/07/2020	0.009
Phosphorus (Total)	mg/L	DG_A_I_SW_DUSW22	6/10/2020	0.015
Phosphorus (Total)	mg/L	DG_A_I_SW_DUSW23	15/07/2020	0.050
Phosphorus (Total)	mg/L	DG_A_I_SW_DUSW24	17/09/2020	0.160
Phosphorus (Total)	mg/L	DG_A_I_SW_DUSW24	13/10/2020	0.210
Phosphorus (Total)	mg/L	DG_A_I_SW_DUSW25	8/10/2020	0.018
Phosphorus (Total)	mg/L	DG_A_I_SW_DUSW26	6/10/2020	0.051
Phosphorus (Total)	mg/L	DG_A_I_SW_DUSW27	20/08/2020	0.320
Phosphorus (Total)	mg/L	DG_A_I_SW_DUSW27	8/10/2020	0.270
Potassium	mg/L	DG_A_I_SW_DUSW05B	17/09/2020	530.000
Potassium	mg/L	DG_A_I_SW_DUSW05B	13/10/2020	530.000
Potassium	mg/L	DG_A_I_SW_DUSW14	15/07/2020	6.700
Potassium	mg/L	DG_A_I_SW_DUSW14	6/10/2020	6.700
Potassium	mg/L	DG_A_I_SW_DUSW19	26/11/2020	4.800
Potassium	mg/L	DG_A_I_SW_DUSW20	14/09/2020	6.400
Potassium	mg/L	DG_A_I_SW_DUSW20	8/10/2020	13.000
Potassium	mg/L	DG_A_I_SW_DUSW22	15/07/2020	11.000
Potassium	mg/L	DG_A_I_SW_DUSW22	6/10/2020	10.000
Potassium	mg/L	DG_A_I_SW_DUSW24	17/09/2020	130.000
Potassium	mg/L	DG_A_I_SW_DUSW24	13/10/2020	140.000
Radium 226	Bq/L	DG_A_I_SW_DUSW05B	17/09/2020	0.020
Radium 226	Bq/L	DG_A_I_SW_DUSW05B	13/10/2020	0.020
Radium 226	Bq/L	DG_A_I_SW_DUSW14	15/07/2020	0.010
Radium 226	Bq/L	DG_A_I_SW_DUSW14	6/10/2020	0.010
Radium 226	Bq/L	DG_A_I_SW_DUSW19	26/11/2020	0.010
Radium 226	Bq/L	DG_A_I_SW_DUSW20	14/09/2020	0.010
Radium 226	Bq/L	DG_A_I_SW_DUSW20	8/10/2020	0.010
Radium 226	Bq/L	DG_A_I_SW_DUSW22	15/07/2020	0.010
Radium 226	Bq/L	DG_A_I_SW_DUSW22	6/10/2020	0.010
Radium 226	Bq/L	DG_A_I_SW_DUSW24	17/09/2020	0.010
Radium 226	Bq/L	DG_A_I_SW_DUSW24	13/10/2020	0.010
Radium 228	Bq/L	DG_A_I_SW_DUSW05B	17/09/2020	0.130
Radium 228	Bq/L	DG_A_I_SW_DUSW05B	13/10/2020	0.110

Variable	Unit	Sample Point	Date	Result
Radium 228	Bq/L	DG_A_I_SW_DUSW14	15/07/2020	0.080
Radium 228	Bq/L	DG_A_I_SW_DUSW14	6/10/2020	0.080
Radium 228	Bq/L	DG_A_I_SW_DUSW19	26/11/2020	0.080
Radium 228	Bq/L	DG_A_I_SW_DUSW20	14/09/2020	0.080
Radium 228	Bq/L	DG_A_I_SW_DUSW20	8/10/2020	0.080
Radium 228	Bq/L	DG_A_I_SW_DUSW22	15/07/2020	0.080
Radium 228	Bq/L	DG_A_I_SW_DUSW22	6/10/2020	0.080
Radium 228	Bq/L	DG_A_I_SW_DUSW24	17/09/2020	0.080
Radium 228	Bq/L	DG_A_I_SW_DUSW24	13/10/2020	0.080
Selenium (Total)	mg/L	DG_A_I_SW_DUSW05B	17/09/2020	0.010
Selenium (Total)	mg/L	DG_A_I_SW_DUSW05B	13/10/2020	0.010
Selenium (Total)	mg/L	DG_A_I_SW_DUSW11	8/10/2020	0.001
Selenium (Total)	mg/L	DG_A_I_SW_DUSW14	15/07/2020	0.001
Selenium (Total)	mg/L	DG_A_I_SW_DUSW14	6/10/2020	0.001
Selenium (Total)	mg/L	DG_A_I_SW_DUSW19	26/11/2020	0.001
Selenium (Total)	mg/L	DG_A_I_SW_DUSW20	14/09/2020	0.001
Selenium (Total)	mg/L	DG_A_I_SW_DUSW20	8/10/2020	0.001
Selenium (Total)	mg/L	DG_A_I_SW_DUSW22	15/07/2020	0.001
Selenium (Total)	mg/L	DG_A_I_SW_DUSW22	6/10/2020	0.001
Selenium (Total)	mg/L	DG_A_I_SW_DUSW24	17/09/2020	0.001
Selenium (Total)	mg/L	DG_A_I_SW_DUSW24	13/10/2020	0.001
Selenium (Total)	mg/L	DG_A_I_SW_DUSW25	8/10/2020	0.001
Selenium (Total)	mg/L	DG_A_I_SW_DUSW27	8/10/2020	0.001
Silver (Total)	mg/L	DG_A_I_SW_DUSW05B	17/09/2020	0.010
Silver (Total)	mg/L	DG_A_I_SW_DUSW05B	13/10/2020	0.010
Silver (Total)	mg/L	DG_A_I_SW_DUSW11	8/10/2020	0.001
Silver (Total)	mg/L	DG_A_I_SW_DUSW14	15/07/2020	0.001
Silver (Total)	mg/L	DG_A_I_SW_DUSW14	6/10/2020	0.001
Silver (Total)	mg/L	DG_A_I_SW_DUSW19	26/11/2020	0.001
Silver (Total)	mg/L	DG_A_I_SW_DUSW20	14/09/2020	0.001
Silver (Total)	mg/L	DG_A_I_SW_DUSW20	8/10/2020	0.001
Silver (Total)	mg/L	DG_A_I_SW_DUSW22	15/07/2020	0.001
Silver (Total)	mg/L	DG_A_I_SW_DUSW22	6/10/2020	0.001
Silver (Total)	mg/L	DG_A_I_SW_DUSW24	17/09/2020	0.001
Silver (Total)	mg/L	DG_A_I_SW_DUSW24	13/10/2020	0.001
Silver (Total)	mg/L	DG_A_I_SW_DUSW25	8/10/2020	0.001
Silver (Total)	mg/L	DG_A_I_SW_DUSW27	8/10/2020	0.001
Sodium	mg/L	DG_A_I_SW_DUSW05B	17/09/2020	56000.000
Sodium	mg/L	DG_A_I_SW_DUSW05B	13/10/2020	52000.000
Sodium	mg/L	DG_A_I_SW_DUSW14	15/07/2020	1400.000
Sodium	mg/L	DG_A_I_SW_DUSW14	6/10/2020	900.000
Sodium	mg/L	DG_A_I_SW_DUSW19	26/11/2020	120.000
Sodium	mg/L	DG_A_I_SW_DUSW20	14/09/2020	46.000
Sodium	mg/L	DG_A_I_SW_DUSW20	8/10/2020	2100.000

Variable	Unit	Sample Point	Date	Result
Sodium	mg/L	DG_A_I_SW_DUSW22	15/07/2020	1600.000
Sodium	mg/L	DG_A_I_SW_DUSW22	6/10/2020	1100.000
Sodium	mg/L	DG_A_I_SW_DUSW24	17/09/2020	2800.000
Sodium	mg/L	DG_A_I_SW_DUSW24	13/10/2020	3000.000
Strontium (Total)	mg/L	DG_A_I_SW_DUSW05B	17/09/2020	40.000
Strontium (Total)	mg/L	DG_A_I_SW_DUSW05B	13/10/2020	44.000
Strontium (Total)	mg/L	DG_A_I_SW_DUSW11	8/10/2020	0.036
Strontium (Total)	mg/L	DG_A_I_SW_DUSW14	15/07/2020	0.890
Strontium (Total)	mg/L	DG_A_I_SW_DUSW14	6/10/2020	0.610
Strontium (Total)	mg/L	DG_A_I_SW_DUSW19	26/11/2020	0.130
Strontium (Total)	mg/L	DG_A_I_SW_DUSW20	14/09/2020	0.045
Strontium (Total)	mg/L	DG_A_I_SW_DUSW20	8/10/2020	1.900
Strontium (Total)	mg/L	DG_A_I_SW_DUSW22	15/07/2020	1.600
Strontium (Total)	mg/L	DG_A_I_SW_DUSW22	6/10/2020	1.300
Strontium (Total)	mg/L	DG_A_I_SW_DUSW24	17/09/2020	11.000
Strontium (Total)	mg/L	DG_A_I_SW_DUSW24	13/10/2020	14.000
Strontium (Total)	mg/L	DG_A_I_SW_DUSW25	8/10/2020	0.099
Strontium (Total)	mg/L	DG_A_I_SW_DUSW27	8/10/2020	0.090
Sulfate	mg/L	DG_A_I_SW_DUSW05B	17/09/2020	6800.000
Sulfate	mg/L	DG_A_I_SW_DUSW05B	13/10/2020	7500.000
Sulfate	mg/L	DG_A_I_SW_DUSW14	15/07/2020	220.000
Sulfate	mg/L	DG_A_I_SW_DUSW14	6/10/2020	240.000
Sulfate	mg/L	DG_A_I_SW_DUSW19	26/11/2020	81.000
Sulfate	mg/L	DG_A_I_SW_DUSW20	14/09/2020	4.000
Sulfate	mg/L	DG_A_I_SW_DUSW20	8/10/2020	560.000
Sulfate	mg/L	DG_A_I_SW_DUSW22	15/07/2020	290.000
Sulfate	mg/L	DG_A_I_SW_DUSW22	6/10/2020	230.000
Sulfate	mg/L	DG_A_I_SW_DUSW24	17/09/2020	900.000
Sulfate	mg/L	DG_A_I_SW_DUSW24	13/10/2020	1200.000
Thallium (Total)	mg/L	DG_A_I_SW_DUSW05B	17/09/2020	0.010
Thallium (Total)	mg/L	DG_A_I_SW_DUSW05B	13/10/2020	0.010
Thallium (Total)	mg/L	DG_A_I_SW_DUSW11	8/10/2020	0.001
Thallium (Total)	mg/L	DG_A_I_SW_DUSW14	15/07/2020	0.001
Thallium (Total)	mg/L	DG_A_I_SW_DUSW14	6/10/2020	0.001
Thallium (Total)	mg/L	DG_A_I_SW_DUSW19	26/11/2020	0.001
Thallium (Total)	mg/L	DG_A_I_SW_DUSW20	14/09/2020	0.001
Thallium (Total)	mg/L	DG_A_I_SW_DUSW20	8/10/2020	0.001
Thallium (Total)	mg/L	DG_A_I_SW_DUSW22	15/07/2020	0.001
Thallium (Total)	mg/L	DG_A_I_SW_DUSW22	6/10/2020	0.001
Thallium (Total)	mg/L	DG_A_I_SW_DUSW24	17/09/2020	0.001
Thallium (Total)	mg/L	DG_A_I_SW_DUSW24	13/10/2020	0.006
Thallium (Total)	mg/L	DG_A_I_SW_DUSW25	8/10/2020	0.001
Thallium (Total)	mg/L	DG_A_I_SW_DUSW27	8/10/2020	0.001
Thorium (Total)	mg/L	DG_A_I_SW_DUSW05B	17/09/2020	0.020

Variable	Unit	Sample Point	Date	Result
Thorium (Total)	mg/L	DG_A_I_SW_DUSW05B	13/10/2020	0.020
Thorium (Total)	mg/L	DG_A_I_SW_DUSW11	8/10/2020	0.002
Thorium (Total)	mg/L	DG_A_I_SW_DUSW14	15/07/2020	0.002
Thorium (Total)	mg/L	DG_A_I_SW_DUSW14	6/10/2020	0.002
Thorium (Total)	mg/L	DG_A_I_SW_DUSW19	26/11/2020	0.002
Thorium (Total)	mg/L	DG_A_I_SW_DUSW20	14/09/2020	0.004
Thorium (Total)	mg/L	DG_A_I_SW_DUSW20	8/10/2020	0.002
Thorium (Total)	mg/L	DG_A_I_SW_DUSW22	15/07/2020	0.002
Thorium (Total)	mg/L	DG_A_I_SW_DUSW22	6/10/2020	0.002
Thorium (Total)	mg/L	DG_A_I_SW_DUSW24	17/09/2020	0.002
Thorium (Total)	mg/L	DG_A_I_SW_DUSW24	13/10/2020	0.002
Thorium (Total)	mg/L	DG_A_I_SW_DUSW25	8/10/2020	0.009
Thorium (Total)	mg/L	DG_A_I_SW_DUSW27	8/10/2020	0.002
Tin (Total)	mg/L	DG_A_I_SW_DUSW05B	17/09/2020	0.010
Tin (Total)	mg/L	DG_A_I_SW_DUSW05B	13/10/2020	0.010
Tin (Total)	mg/L	DG_A_I_SW_DUSW11	8/10/2020	0.001
Tin (Total)	mg/L	DG_A_I_SW_DUSW14	15/07/2020	0.001
Tin (Total)	mg/L	DG_A_I_SW_DUSW14	6/10/2020	0.001
Tin (Total)	mg/L	DG_A_I_SW_DUSW19	26/11/2020	0.001
Tin (Total)	mg/L	DG_A_I_SW_DUSW20	14/09/2020	0.001
Tin (Total)	mg/L	DG_A_I_SW_DUSW20	8/10/2020	0.001
Tin (Total)	mg/L	DG_A_I_SW_DUSW22	15/07/2020	0.001
Tin (Total)	mg/L	DG_A_I_SW_DUSW22	6/10/2020	0.001
Tin (Total)	mg/L	DG_A_I_SW_DUSW24	17/09/2020	0.001
Tin (Total)	mg/L	DG_A_I_SW_DUSW24	13/10/2020	0.001
Tin (Total)	mg/L	DG_A_I_SW_DUSW25	8/10/2020	0.002
Tin (Total)	mg/L	DG_A_I_SW_DUSW27	8/10/2020	0.001
Titanium (Total)	mg/L	DG_A_I_SW_DUSW05B	17/09/2020	0.010
Titanium (Total)	mg/L	DG_A_I_SW_DUSW05B	13/10/2020	0.020
Titanium (Total)	mg/L	DG_A_I_SW_DUSW11	8/10/2020	0.340
Titanium (Total)	mg/L	DG_A_I_SW_DUSW14	15/07/2020	0.010
Titanium (Total)	mg/L	DG_A_I_SW_DUSW14	6/10/2020	0.080
Titanium (Total)	mg/L	DG_A_I_SW_DUSW19	26/11/2020	0.003
Titanium (Total)	mg/L	DG_A_I_SW_DUSW20	14/09/2020	0.570
Titanium (Total)	mg/L	DG_A_I_SW_DUSW20	8/10/2020	0.010
Titanium (Total)	mg/L	DG_A_I_SW_DUSW22	15/07/2020	0.003
Titanium (Total)	mg/L	DG_A_I_SW_DUSW22	6/10/2020	0.002
Titanium (Total)	mg/L	DG_A_I_SW_DUSW24	17/09/2020	0.001
Titanium (Total)	mg/L	DG_A_I_SW_DUSW24	13/10/2020	0.001
Titanium (Total)	mg/L	DG_A_I_SW_DUSW25	8/10/2020	1.900
Titanium (Total)	mg/L	DG_A_I_SW_DUSW27	8/10/2020	0.190
Total Dissolved Solids	mg/L	DG_A_I_SW_DUSW05B	17/09/2020	170000.000
Total Dissolved Solids	mg/L	DG_A_I_SW_DUSW05B	13/10/2020	160000.000
Total Dissolved Solids	mg/L	DG_A_I_SW_DUSW11	8/10/2020	170.000

Variable	Unit	Sample Point	Date	Result
Total Dissolved Solids	mg/L	DG_A_I_SW_DUSW14	15/07/2020	4400.000
Total Dissolved Solids	mg/L	DG_A_I_SW_DUSW14	6/10/2020	3000.000
Total Dissolved Solids	mg/L	DG_A_I_SW_DUSW17	7/10/2020	3400.000
Total Dissolved Solids	mg/L	DG_A_I_SW_DUSW19	7/10/2020	590.000
Total Dissolved Solids	mg/L	DG_A_I_SW_DUSW19	26/11/2020	490.000
Total Dissolved Solids	mg/L	DG_A_I_SW_DUSW20	14/09/2020	460.000
Total Dissolved Solids	mg/L	DG_A_I_SW_DUSW20	8/10/2020	7700.000
Total Dissolved Solids	mg/L	DG_A_I_SW_DUSW22	15/07/2020	6300.000
Total Dissolved Solids	mg/L	DG_A_I_SW_DUSW22	6/10/2020	4900.000
Total Dissolved Solids	mg/L	DG_A_I_SW_DUSW24	17/09/2020	9900.000
Total Dissolved Solids	mg/L	DG_A_I_SW_DUSW24	13/10/2020	12000.000
Total Dissolved Solids	mg/L	DG_A_I_SW_DUSW25	8/10/2020	860.000
Total Dissolved Solids	mg/L	DG_A_I_SW_DUSW26	6/10/2020	2900.000
Total Dissolved Solids	mg/L	DG_A_I_SW_DUSW27	20/08/2020	370.000
Total Dissolved Solids	mg/L	DG_A_I_SW_DUSW27	8/10/2020	220.000
Total Kjeldahl Nitrogen	mg/L	DG_A_I_SW_DUSW05B	17/09/2020	1.000
Total Kjeldahl Nitrogen	mg/L	DG_A_I_SW_DUSW05B	13/10/2020	1.400
Total Kjeldahl Nitrogen	mg/L	DG_A_I_SW_DUSW11	8/10/2020	2.300
Total Kjeldahl Nitrogen	mg/L	DG_A_I_SW_DUSW14	15/07/2020	0.790
Total Kjeldahl Nitrogen	mg/L	DG_A_I_SW_DUSW14	6/10/2020	0.770
Total Kjeldahl Nitrogen	mg/L	DG_A_I_SW_DUSW17	7/10/2020	2.000
Total Kjeldahl Nitrogen	mg/L	DG_A_I_SW_DUSW19	7/10/2020	0.730
Total Kjeldahl Nitrogen	mg/L	DG_A_I_SW_DUSW19	26/11/2020	0.760
Total Kjeldahl Nitrogen	mg/L	DG_A_I_SW_DUSW20	14/09/2020	2.700
Total Kjeldahl Nitrogen	mg/L	DG_A_I_SW_DUSW20	8/10/2020	1.500
Total Kjeldahl Nitrogen	mg/L	DG_A_I_SW_DUSW22	15/07/2020	0.320
Total Kjeldahl Nitrogen	mg/L	DG_A_I_SW_DUSW22	6/10/2020	0.370
Total Kjeldahl Nitrogen	mg/L	DG_A_I_SW_DUSW24	17/09/2020	6.600
Total Kjeldahl Nitrogen	mg/L	DG_A_I_SW_DUSW24	13/10/2020	5.800
Total Kjeldahl Nitrogen	mg/L	DG_A_I_SW_DUSW25	8/10/2020	1.700
Total Kjeldahl Nitrogen	mg/L	DG_A_I_SW_DUSW26	6/10/2020	0.020
Total Kjeldahl Nitrogen	mg/L	DG_A_I_SW_DUSW27	20/08/2020	3.900
Total Kjeldahl Nitrogen	mg/L	DG_A_I_SW_DUSW27	8/10/2020	3.200
Total Oxidised Nitrogen as N	mg/L	DG_A_I_SW_DUSW05B	17/09/2020	0.100
Total Oxidised Nitrogen as N	mg/L	DG_A_I_SW_DUSW05B	13/10/2020	0.006
Total Oxidised Nitrogen as N	mg/L	DG_A_I_SW_DUSW14	15/07/2020	0.048
Total Oxidised Nitrogen as N	mg/L	DG_A_I_SW_DUSW14	6/10/2020	0.006
Total Oxidised Nitrogen as N	mg/L	DG_A_I_SW_DUSW19	26/11/2020	0.019
Total Oxidised Nitrogen as N	mg/L	DG_A_I_SW_DUSW20	14/09/2020	0.020
Total Oxidised Nitrogen as N	mg/L	DG_A_I_SW_DUSW20	8/10/2020	0.006
Total Oxidised Nitrogen as N	mg/L	DG_A_I_SW_DUSW22	15/07/2020	0.006
Total Oxidised Nitrogen as N	mg/L	DG_A_I_SW_DUSW22	6/10/2020	0.006
Total Oxidised Nitrogen as N	mg/L	DG_A_I_SW_DUSW24	17/09/2020	0.010
Total Oxidised Nitrogen as N	mg/L	DG_A_I_SW_DUSW24	13/10/2020	0.086

Variable	Unit	Sample Point	Date	Result
Total Suspended Solids	mg/L	DG_A_I_SW_DUSW05B	17/09/2020	280.000
Total Suspended Solids	mg/L	DG_A_I_SW_DUSW05B	13/10/2020	610.000
Total Suspended Solids	mg/L	DG_A_I_SW_DUSW11	8/10/2020	52.000
Total Suspended Solids	mg/L	DG_A_I_SW_DUSW14	15/07/2020	10.000
Total Suspended Solids	mg/L	DG_A_I_SW_DUSW14	6/10/2020	16.000
Total Suspended Solids	mg/L	DG_A_I_SW_DUSW17	7/10/2020	190.000
Total Suspended Solids	mg/L	DG_A_I_SW_DUSW19	7/10/2020	7.000
Total Suspended Solids	mg/L	DG_A_I_SW_DUSW19	26/11/2020	12.000
Total Suspended Solids	mg/L	DG_A_I_SW_DUSW20	14/09/2020	180.000
Total Suspended Solids	mg/L	DG_A_I_SW_DUSW20	8/10/2020	2.000
Total Suspended Solids	mg/L	DG_A_I_SW_DUSW22	15/07/2020	4.000
Total Suspended Solids	mg/L	DG_A_I_SW_DUSW22	6/10/2020	1.000
Total Suspended Solids	mg/L	DG_A_I_SW_DUSW23	15/07/2020	54.000
Total Suspended Solids	mg/L	DG_A_I_SW_DUSW24	17/09/2020	10.000
Total Suspended Solids	mg/L	DG_A_I_SW_DUSW24	13/10/2020	24.000
Total Suspended Solids	mg/L	DG_A_I_SW_DUSW25	8/10/2020	250.000
Total Suspended Solids	mg/L	DG_A_I_SW_DUSW26	6/10/2020	36.000
Total Suspended Solids	mg/L	DG_A_I_SW_DUSW27	20/08/2020	32.000
Total Suspended Solids	mg/L	DG_A_I_SW_DUSW27	8/10/2020	43.000
Turbidity	NTU	DG_A_I_SW_DUSW17	7/10/2020	2700.000
Turbidity	NTU	DG_A_I_SW_DUSW19	7/10/2020	81.000
Turbidity	NTU	DG_A_I_SW_DUSW26	6/10/2020	2200.000
Turbidity	NTU	DG_A_I_SW_DUSW27	20/08/2020	180.000
Uranium (Total)	mg/L	DG_A_I_SW_DUSW05B	17/09/2020	0.010
Uranium (Total)	mg/L	DG_A_I_SW_DUSW05B	13/10/2020	0.002
Uranium (Total)	mg/L	DG_A_I_SW_DUSW05B	13/10/2020	0.010
Uranium (Total)	mg/L	DG_A_I_SW_DUSW11	8/10/2020	0.001
Uranium (Total)	mg/L	DG_A_I_SW_DUSW14	15/07/2020	0.002
Uranium (Total)	mg/L	DG_A_I_SW_DUSW14	15/07/2020	0.001
Uranium (Total)	mg/L	DG_A_I_SW_DUSW14	6/10/2020	0.002
Uranium (Total)	mg/L	DG_A_I_SW_DUSW14	6/10/2020	0.001
Uranium (Total)	mg/L	DG_A_I_SW_DUSW19	26/11/2020	0.002
Uranium (Total)	mg/L	DG_A_I_SW_DUSW19	26/11/2020	0.001
Uranium (Total)	mg/L	DG_A_I_SW_DUSW20	14/09/2020	0.001
Uranium (Total)	mg/L	DG_A_I_SW_DUSW20	8/10/2020	0.002
Uranium (Total)	mg/L	DG_A_I_SW_DUSW20	8/10/2020	0.001
Uranium (Total)	mg/L	DG_A_I_SW_DUSW22	15/07/2020	0.002
Uranium (Total)	mg/L	DG_A_I_SW_DUSW22	15/07/2020	0.001
Uranium (Total)	mg/L	DG_A_I_SW_DUSW22	6/10/2020	0.002
Uranium (Total)	mg/L	DG_A_I_SW_DUSW22	6/10/2020	0.001
Uranium (Total)	mg/L	DG_A_I_SW_DUSW24	17/09/2020	0.004
Uranium (Total)	mg/L	DG_A_I_SW_DUSW24	17/09/2020	0.007
Uranium (Total)	mg/L	DG_A_I_SW_DUSW24	13/10/2020	0.002
Uranium (Total)	mg/L	DG_A_I_SW_DUSW24	13/10/2020	0.004

Variable	Unit	Sample Point	Date	Result
Uranium (Total)	mg/L	DG_A_I_SW_DUSW25	8/10/2020	0.002
Uranium (Total)	mg/L	DG_A_I_SW_DUSW27	8/10/2020	<i>0.001</i>
Uranium 238	Bq/L	DG_A_I_SW_DUSW05B	13/10/2020	<i>0.025</i>
Uranium 238	Bq/L	DG_A_I_SW_DUSW14	15/07/2020	<i>0.025</i>
Uranium 238	Bq/L	DG_A_I_SW_DUSW14	6/10/2020	<i>0.025</i>
Uranium 238	Bq/L	DG_A_I_SW_DUSW19	26/11/2020	<i>0.025</i>
Uranium 238	Bq/L	DG_A_I_SW_DUSW20	14/09/2020	<i>0.025</i>
Uranium 238	Bq/L	DG_A_I_SW_DUSW20	8/10/2020	<i>0.025</i>
Uranium 238	Bq/L	DG_A_I_SW_DUSW22	15/07/2020	<i>0.025</i>
Uranium 238	Bq/L	DG_A_I_SW_DUSW22	6/10/2020	<i>0.025</i>
Uranium 238	Bq/L	DG_A_I_SW_DUSW24	17/09/2020	0.049
Uranium 238	Bq/L	DG_A_I_SW_DUSW24	13/10/2020	<i>0.025</i>
Vanadium (Total)	mg/L	DG_A_I_SW_DUSW05B	17/09/2020	<i>0.010</i>
Vanadium (Total)	mg/L	DG_A_I_SW_DUSW05B	13/10/2020	0.020
Vanadium (Total)	mg/L	DG_A_I_SW_DUSW11	8/10/2020	0.013
Vanadium (Total)	mg/L	DG_A_I_SW_DUSW14	15/07/2020	<i>0.001</i>
Vanadium (Total)	mg/L	DG_A_I_SW_DUSW14	6/10/2020	0.003
Vanadium (Total)	mg/L	DG_A_I_SW_DUSW19	26/11/2020	0.002
Vanadium (Total)	mg/L	DG_A_I_SW_DUSW20	14/09/2020	0.029
Vanadium (Total)	mg/L	DG_A_I_SW_DUSW20	8/10/2020	0.001
Vanadium (Total)	mg/L	DG_A_I_SW_DUSW22	15/07/2020	<i>0.001</i>
Vanadium (Total)	mg/L	DG_A_I_SW_DUSW22	6/10/2020	<i>0.001</i>
Vanadium (Total)	mg/L	DG_A_I_SW_DUSW24	17/09/2020	0.007
Vanadium (Total)	mg/L	DG_A_I_SW_DUSW24	13/10/2020	0.003
Vanadium (Total)	mg/L	DG_A_I_SW_DUSW25	8/10/2020	0.082
Vanadium (Total)	mg/L	DG_A_I_SW_DUSW27	8/10/2020	0.010
Zinc (Total)	mg/L	DG_A_I_SW_DUSW05B	17/09/2020	<i>0.010</i>
Zinc (Total)	mg/L	DG_A_I_SW_DUSW05B	13/10/2020	<i>0.010</i>
Zinc (Total)	mg/L	DG_A_I_SW_DUSW11	8/10/2020	0.022
Zinc (Total)	mg/L	DG_A_I_SW_DUSW14	15/07/2020	0.004
Zinc (Total)	mg/L	DG_A_I_SW_DUSW14	6/10/2020	0.006
Zinc (Total)	mg/L	DG_A_I_SW_DUSW19	26/11/2020	0.002
Zinc (Total)	mg/L	DG_A_I_SW_DUSW20	14/09/2020	0.120
Zinc (Total)	mg/L	DG_A_I_SW_DUSW20	8/10/2020	0.039
Zinc (Total)	mg/L	DG_A_I_SW_DUSW22	15/07/2020	0.007
Zinc (Total)	mg/L	DG_A_I_SW_DUSW22	6/10/2020	0.009
Zinc (Total)	mg/L	DG_A_I_SW_DUSW24	17/09/2020	0.007
Zinc (Total)	mg/L	DG_A_I_SW_DUSW24	13/10/2020	0.003
Zinc (Total)	mg/L	DG_A_I_SW_DUSW25	8/10/2020	0.029
Zinc (Total)	mg/L	DG_A_I_SW_DUSW27	8/10/2020	0.023

Results that are italicised represent less than values i.e. *0.001* = <0.001

Appendix E: Monitoring Data (Field) – Surface water

Variable	Unit	Sample Point	Date	Result
Dissolved Oxygen	mg/L	DG_A_I_SW_DUSW05B	17/09/2020	7.3
Dissolved Oxygen	%	DG_A_I_SW_DUSW05B	17/09/2020	194
Dissolved Oxygen	mg/L	DG_A_I_SW_DUSW05B	13/10/2020	5.9
Dissolved Oxygen	%	DG_A_I_SW_DUSW05B	13/10/2020	157
Dissolved Oxygen	mg/L	DG_A_I_SW_DUSW11	8/10/2020	10.2
Dissolved Oxygen	%	DG_A_I_SW_DUSW11	8/10/2020	101
Dissolved Oxygen	mg/L	DG_A_I_SW_DUSW14	15/07/2020	12.2
Dissolved Oxygen	%	DG_A_I_SW_DUSW14	15/07/2020	109
Dissolved Oxygen	mg/L	DG_A_I_SW_DUSW14	6/10/2020	12.6
Dissolved Oxygen	%	DG_A_I_SW_DUSW14	6/10/2020	120
Dissolved Oxygen	mg/L	DG_A_I_SW_DUSW17	15/01/2020	10.4
Dissolved Oxygen	%	DG_A_I_SW_DUSW17	15/01/2020	102
Dissolved Oxygen	mg/L	DG_A_I_SW_DUSW17	7/10/2020	9.9
Dissolved Oxygen	%	DG_A_I_SW_DUSW17	7/10/2020	93
Dissolved Oxygen	mg/L	DG_A_I_SW_DUSW19	15/01/2020	12.4
Dissolved Oxygen	%	DG_A_I_SW_DUSW19	15/01/2020	115
Dissolved Oxygen	mg/L	DG_A_I_SW_DUSW19	7/10/2020	9.9
Dissolved Oxygen	%	DG_A_I_SW_DUSW19	7/10/2020	98
Dissolved Oxygen	mg/L	DG_A_I_SW_DUSW19	26/11/2020	9.1
Dissolved Oxygen	%	DG_A_I_SW_DUSW19	26/11/2020	103
Dissolved Oxygen	mg/L	DG_A_I_SW_DUSW20	8/10/2020	8.9
Dissolved Oxygen	%	DG_A_I_SW_DUSW20	8/10/2020	89
Dissolved Oxygen	mg/L	DG_A_I_SW_DUSW22	15/07/2020	11
Dissolved Oxygen	%	DG_A_I_SW_DUSW22	15/07/2020	90
Dissolved Oxygen	mg/L	DG_A_I_SW_DUSW22	6/10/2020	9.9
Dissolved Oxygen	%	DG_A_I_SW_DUSW22	6/10/2020	93
Dissolved Oxygen	mg/L	DG_A_I_SW_DUSW23	15/07/2020	11.5
Dissolved Oxygen	%	DG_A_I_SW_DUSW23	15/07/2020	96
Dissolved Oxygen	mg/L	DG_A_I_SW_DUSW24	17/09/2020	11
Dissolved Oxygen	%	DG_A_I_SW_DUSW24	17/09/2020	123
Dissolved Oxygen	mg/L	DG_A_I_SW_DUSW24	13/10/2020	15.8
Dissolved Oxygen	%	DG_A_I_SW_DUSW24	13/10/2020	179
Dissolved Oxygen	mg/L	DG_A_I_SW_DUSW25	8/10/2020	7.6
Dissolved Oxygen	%	DG_A_I_SW_DUSW25	8/10/2020	73
Dissolved Oxygen	mg/L	DG_A_I_SW_DUSW26	15/07/2020	10.9
Dissolved Oxygen	%	DG_A_I_SW_DUSW26	15/07/2020	93
Dissolved Oxygen	mg/L	DG_A_I_SW_DUSW26	6/10/2020	10.7
Dissolved Oxygen	%	DG_A_I_SW_DUSW26	6/10/2020	98
Dissolved Oxygen	mg/L	DG_A_I_SW_DUSW27	20/08/2020	9.4
Dissolved Oxygen	%	DG_A_I_SW_DUSW27	20/08/2020	82
Dissolved Oxygen	mg/L	DG_A_I_SW_DUSW27	8/10/2020	7.2
Dissolved Oxygen	%	DG_A_I_SW_DUSW27	8/10/2020	70

Variable	Unit	Sample Point	Date	Result
Electrical Conductivity	µS/cm	DG_A_I_SW_DUSW05B	17/09/2020	180514
Electrical Conductivity	µS/cm	DG_A_I_SW_DUSW05B	13/10/2020	170938
Electrical Conductivity	µS/cm	DG_A_I_SW_DUSW11	8/10/2020	75
Electrical Conductivity	µS/cm	DG_A_I_SW_DUSW14	15/07/2020	7738
Electrical Conductivity	µS/cm	DG_A_I_SW_DUSW14	6/10/2020	5146
Electrical Conductivity	µS/cm	DG_A_I_SW_DUSW17	15/01/2020	340
Electrical Conductivity	µS/cm	DG_A_I_SW_DUSW17	7/10/2020	290
Electrical Conductivity	µS/cm	DG_A_I_SW_DUSW19	15/01/2020	960
Electrical Conductivity	µS/cm	DG_A_I_SW_DUSW19	7/10/2020	865
Electrical Conductivity	µS/cm	DG_A_I_SW_DUSW19	26/11/2020	882
Electrical Conductivity	µS/cm	DG_A_I_SW_DUSW20	14/09/2020	257
Electrical Conductivity	µS/cm	DG_A_I_SW_DUSW20	8/10/2020	11676
Electrical Conductivity	µS/cm	DG_A_I_SW_DUSW22	15/07/2020	10531
Electrical Conductivity	µS/cm	DG_A_I_SW_DUSW22	6/10/2020	7338
Electrical Conductivity	µS/cm	DG_A_I_SW_DUSW23	15/07/2020	430
Electrical Conductivity	µS/cm	DG_A_I_SW_DUSW24	17/09/2020	16427
Electrical Conductivity	µS/cm	DG_A_I_SW_DUSW24	13/10/2020	17612
Electrical Conductivity	µS/cm	DG_A_I_SW_DUSW25	8/10/2020	194
Electrical Conductivity	µS/cm	DG_A_I_SW_DUSW26	15/07/2020	230
Electrical Conductivity	µS/cm	DG_A_I_SW_DUSW26	6/10/2020	236
Electrical Conductivity	µS/cm	DG_A_I_SW_DUSW27	20/08/2020	239
Electrical Conductivity	µS/cm	DG_A_I_SW_DUSW27	8/10/2020	138
pH	pH units	DG_A_I_SW_DUSW05B	17/09/2020	8.48
pH	pH units	DG_A_I_SW_DUSW05B	13/10/2020	8.56
pH	pH units	DG_A_I_SW_DUSW11	8/10/2020	7.46
pH	pH units	DG_A_I_SW_DUSW14	15/07/2020	7.35
pH	pH units	DG_A_I_SW_DUSW14	6/10/2020	7.37
pH	pH units	DG_A_I_SW_DUSW17	15/07/2020	8.26
pH	pH units	DG_A_I_SW_DUSW17	7/10/2020	8.04
pH	pH units	DG_A_I_SW_DUSW19	15/01/2020	8.15
pH	pH units	DG_A_I_SW_DUSW19	7/10/2020	7.9
pH	pH units	DG_A_I_SW_DUSW19	26/11/2020	7.96
pH	pH units	DG_A_I_SW_DUSW20	14/09/2020	8.13
pH	pH units	DG_A_I_SW_DUSW20	8/10/2020	7.74
pH	pH units	DG_A_I_SW_DUSW22	15/07/2020	7.7
pH	pH units	DG_A_I_SW_DUSW22	6/10/2020	7.68
pH	pH units	DG_A_I_SW_DUSW23	15/07/2020	8
pH	pH units	DG_A_I_SW_DUSW24	17/09/2020	9
pH	pH units	DG_A_I_SW_DUSW24	13/10/2020	8.48
pH	pH units	DG_A_I_SW_DUSW25	8/10/2020	7.25
pH	pH units	DG_A_I_SW_DUSW26	15/07/2020	8.6
pH	pH units	DG_A_I_SW_DUSW26	6/10/2020	8.21
pH	pH units	DG_A_I_SW_DUSW27	20/08/2020	6.61
pH	pH units	DG_A_I_SW_DUSW27	8/10/2020	7.49

Variable	Unit	Sample Point	Date	Result
Redox Potential (Eh)	mV	DG_A_I_SW_DUSW05B	17/09/2020	210
Redox Potential (Eh)	mV	DG_A_I_SW_DUSW05B	13/10/2020	211
Redox Potential (Eh)	mV	DG_A_I_SW_DUSW11	8/10/2020	244
Redox Potential (Eh)	mV	DG_A_I_SW_DUSW14	15/07/2020	180
Redox Potential (Eh)	mV	DG_A_I_SW_DUSW14	6/10/2020	162
Redox Potential (Eh)	mV	DG_A_I_SW_DUSW17	15/01/2020	258
Redox Potential (Eh)	mV	DG_A_I_SW_DUSW17	7/10/2020	203
Redox Potential (Eh)	mV	DG_A_I_SW_DUSW19	15/01/2020	221
Redox Potential (Eh)	mV	DG_A_I_SW_DUSW19	7/10/2020	185
Redox Potential (Eh)	mV	DG_A_I_SW_DUSW19	26/11/2020	121
Redox Potential (Eh)	mV	DG_A_I_SW_DUSW20	14/09/2020	246
Redox Potential (Eh)	mV	DG_A_I_SW_DUSW20	8/10/2020	186
Redox Potential (Eh)	mV	DG_A_I_SW_DUSW22	15/07/2020	76
Redox Potential (Eh)	mV	DG_A_I_SW_DUSW22	6/10/2020	178
Redox Potential (Eh)	mV	DG_A_I_SW_DUSW23	15/07/2020	186
Redox Potential (Eh)	mV	DG_A_I_SW_DUSW24	17/09/2020	125
Redox Potential (Eh)	mV	DG_A_I_SW_DUSW24	13/10/2020	166
Redox Potential (Eh)	mV	DG_A_I_SW_DUSW25	8/10/2020	217
Redox Potential (Eh)	mV	DG_A_I_SW_DUSW26	15/07/2020	134
Redox Potential (Eh)	mV	DG_A_I_SW_DUSW26	6/10/2020	200
Redox Potential (Eh)	mV	DG_A_I_SW_DUSW27	20/08/2020	211
Redox Potential (Eh)	mV	DG_A_I_SW_DUSW27	8/10/2020	192
Temperature (Water)	°C	DG_A_I_SW_DUSW05B	17/09/2020	17.5
Temperature (Water)	°C	DG_A_I_SW_DUSW05B	13/10/2020	21.4
Temperature (Water)	°C	DG_A_I_SW_DUSW11	8/10/2020	13.3
Temperature (Water)	°C	DG_A_I_SW_DUSW14	15/07/2020	8.9
Temperature (Water)	°C	DG_A_I_SW_DUSW14	6/10/2020	11.8
Temperature (Water)	°C	DG_A_I_SW_DUSW17	15/01/2020	11.7
Temperature (Water)	°C	DG_A_I_SW_DUSW17	7/10/2020	11.9
Temperature (Water)	°C	DG_A_I_SW_DUSW19	15/01/2020	11.2
Temperature (Water)	°C	DG_A_I_SW_DUSW19	7/10/2020	13.7
Temperature (Water)	°C	DG_A_I_SW_DUSW19	26/11/2020	20.6
Temperature (Water)	°C	DG_A_I_SW_DUSW20	14/09/2020	12.2
Temperature (Water)	°C	DG_A_I_SW_DUSW20	8/10/2020	12.1
Temperature (Water)	°C	DG_A_I_SW_DUSW22	15/07/2020	4.8
Temperature (Water)	°C	DG_A_I_SW_DUSW22	6/10/2020	11.5
Temperature (Water)	°C	DG_A_I_SW_DUSW23	15/07/2020	6.9
Temperature (Water)	°C	DG_A_I_SW_DUSW24	17/09/2020	13.7
Temperature (Water)	°C	DG_A_I_SW_DUSW24	13/10/2020	17.9
Temperature (Water)	°C	DG_A_I_SW_DUSW25	8/10/2020	11.4
Temperature (Water)	°C	DG_A_I_SW_DUSW26	15/07/2020	7.5
Temperature (Water)	°C	DG_A_I_SW_DUSW26	6/10/2020	11
Temperature (Water)	°C	DG_A_I_SW_DUSW27	20/08/2020	8.1
Temperature (Water)	°C	DG_A_I_SW_DUSW27	8/10/2020	11.8

Variable	Unit	Sample Point	Date	Result
Turbidity	NTU	DG_A_I_SW_DUSW05B	17/09/2020	102
Turbidity	NTU	DG_A_I_SW_DUSW05B	13/10/2020	174
Turbidity	NTU	DG_A_I_SW_DUSW11	8/10/2020	136
Turbidity	NTU	DG_A_I_SW_DUSW14	15/07/2020	38.8
Turbidity	NTU	DG_A_I_SW_DUSW14	6/10/2020	42.6
Turbidity	NTU	DG_A_I_SW_DUSW17	15/07/2020	2600
Turbidity	NTU	DG_A_I_SW_DUSW17	7/10/2020	2700
Turbidity	NTU	DG_A_I_SW_DUSW19	15/01/2020	24.9
Turbidity	NTU	DG_A_I_SW_DUSW19	7/10/2020	75
Turbidity	NTU	DG_A_I_SW_DUSW19	26/11/2020	26.1
Turbidity	NTU	DG_A_I_SW_DUSW20	14/09/2020	164
Turbidity	NTU	DG_A_I_SW_DUSW20	8/10/2020	59.2
Turbidity	NTU	DG_A_I_SW_DUSW22	15/07/2020	5.8
Turbidity	NTU	DG_A_I_SW_DUSW22	6/10/2020	5.4
Turbidity	NTU	DG_A_I_SW_DUSW23	15/07/2020	566
Turbidity	NTU	DG_A_I_SW_DUSW24	17/09/2020	6.6
Turbidity	NTU	DG_A_I_SW_DUSW24	13/10/2020	6.1
Turbidity	NTU	DG_A_I_SW_DUSW25	8/10/2020	781
Turbidity	NTU	DG_A_I_SW_DUSW26	15/07/2020	897
Turbidity	NTU	DG_A_I_SW_DUSW26	6/10/2020	867
Turbidity	NTU	DG_A_I_SW_DUSW27	8/10/2020	208

APPENDIX E

Important Information

The document ("Report") to which this page is attached and which this page forms a part of, has been issued by Golder Associates Pty Ltd ("Golder") subject to the important limitations and other qualifications set out below.

This Report constitutes or is part of services ("Services") provided by Golder to its client ("Client") under and subject to a contract between Golder and its Client ("Contract"). The contents of this page are not intended to and do not alter Golder's obligations (including any limits on those obligations) to its Client under the Contract.

This Report is provided for use solely by Golder's Client and persons acting on the Client's behalf, such as its professional advisers. Golder is responsible only to its Client for this Report. Golder has no responsibility to any other person who relies or makes decisions based upon this Report or who makes any other use of this Report. Golder accepts no responsibility for any loss or damage suffered by any person other than its Client as a result of any reliance upon any part of this Report, decisions made based upon this Report or any other use of it.

This Report has been prepared in the context of the circumstances and purposes referred to in, or derived from, the Contract and Golder accepts no responsibility for use of the Report, in whole or in part, in any other context or circumstance or for any other purpose.

The scope of Golder's Services and the period of time they relate to are determined by the Contract and are subject to restrictions and limitations set out in the Contract. If a service or other work is not expressly referred to in this Report, do not assume that it has been provided or performed. If a matter is not addressed in this Report, do not assume that any determination has been made by Golder in regards to it.

At any location relevant to the Services conditions may exist which were not detected by Golder, in particular due to the specific scope of the investigation Golder has been engaged to undertake. Conditions can only be verified at the exact location of any tests undertaken. Variations in conditions may occur between tested locations and there may be conditions which have not been revealed by the investigation and which have not therefore been taken into account in this Report.

Golder accepts no responsibility for and makes no representation as to the accuracy or completeness of the information provided to it by or on behalf of the Client or sourced from any third party. Golder has assumed that such information is correct unless otherwise stated and no responsibility is accepted by Golder for incomplete or inaccurate data supplied by its Client or any other person for whom Golder is not responsible. Golder has not taken account of matters that may have existed when the Report was prepared but which were only later disclosed to Golder.

Having regard to the matters referred to in the previous paragraphs on this page in particular, carrying out the Services has allowed Golder to form no more than an opinion as to the actual conditions at any relevant location. That opinion is necessarily constrained by the extent of the information collected by Golder or otherwise made available to Golder. Further, the passage of time may affect the accuracy, applicability or usefulness of the opinions, assessments or other information in this Report. This Report is based upon the information and other circumstances that existed and were known to Golder when the Services were performed and this Report was prepared. Golder has not considered the effect of any possible future developments including physical changes to any relevant location or changes to any laws or regulations relevant to such location.

Where permitted by the Contract, Golder may have retained subconsultants affiliated with Golder to provide some or all of the Services. However, it is Golder which remains solely responsible for the Services and there is no legal recourse against any of Golder's affiliated companies or the employees, officers or directors of any of them.

By date, or revision, the Report supersedes any prior report or other document issued by Golder dealing with any matter that is addressed in the Report.

Any uncertainty as to the extent to which this Report can be used or relied upon in any respect should be referred to Golder for clarification



golder.com